

WT3000
Precision Power Analyzer
Expansion Function
USER'S MANUAL

Thank you for purchasing the WT3000 Precision Power Analyzer.

This Expansion Function User's Manual contains useful information about the operating procedures and lists the handling precautions of the expansion functions. To ensure correct use, please read this manual thoroughly before beginning operation. After reading the manual, keep it in a convenient location for quick reference whenever a question arises during operation.

Three manuals, including this one, are provided as manuals for the WT3000. Please read all of them.

Manual Title	Manual No.	Description
WT3000 Precision Power Analyzer User's Manual (Vol 1/3)	IM 760301-01E	Explains all functions and procedures of the WT3000 excluding the expansion functions and communication functions.
WT3000 Precision Power Analyzer Communication Interface User's Manual (CD-ROM) (Vol 2/3)	IM 760301-17E	Explains the functions for controlling the WT3000 using communication commands.
WT3000 Precision Power Analyzer Expansion Function User's Manual (Vol 3/3)	IM 760301-51E	This manual. Explains the expansion functions (motor evaluation function and options) of the WT3000 and their operating procedures.

Note

- The contents of this manual are subject to change without prior notice as a result of continuing improvements to the instrument's performance and functions. The figures given in this manual may differ from those that actually appear on your screen.
- Every effort has been made in the preparation of this manual to ensure the accuracy of its contents. However, should you have any questions or find any errors, please contact your nearest YOKOGAWA dealer.
- Copying or reproducing all or any part of the contents of this manual without the permission of Yokogawa Electric Corporation is strictly prohibited.
- The TCP/IP software of this product and the document concerning the TCP/IP software have been developed/created by YOKOGAWA based on the BSD Networking Software, Release 1 that has been licensed from the University of California.

Trademarks

- Microsoft, Internet Explorer, MS-DOS, Windows, Windows NT, and Windows XP are either registered trademarks or trademarks of Microsoft Corporation in the United States and/or other countries.
- Adobe, Acrobat, and PostScript are trademarks of Adobe Systems Incorporated.
- For purposes of this manual, the TM and ® symbols do not accompany their respective trademark names or registered trademark names.
- Other company and product names are trademarks or registered trademarks of their respective holders.

Revisions

- 1st Edition December 2004
- 2nd Edition June 2005
- 3rd Edition January 2006
- 4th Edition December 2006
- 5th Edition March 2007

Safety Precautions

This instrument is an IEC safety class 01 instrument (provided with a terminal for protective earth grounding).

The general safety precautions described in the *User's Manual IM760301-01E* and this manual (IM760301-51E) must be observed during all phases of operation. If the instrument is used in a manner not specified in these manuals, the protection provided by the instrument may be impaired. Yokogawa Electric Corporation assumes no liability for the customer's failure to comply with these requirements.

Conventions Used in This Manual

Safety Markings

The following markings are used in this manual.



Improper handling or use can lead to injury to the user or damage to the instrument. This symbol appears on the instrument to indicate that the user must refer to the user's manual for special instructions. The same symbol appears in the corresponding place in the user's manual to identify those instructions. In the manual, the symbol is used in conjunction with the word "WARNING" or "CAUTION."

WARNING

Calls attention to actions or conditions that could cause serious or fatal injury to the user, and precautions that can be taken to prevent such occurrences.

CAUTION

Calls attentions to actions or conditions that could cause light injury to the user or damage to the instrument or user's data, and precautions that can be taken to prevent such occurrences.

Note

Calls attention to information that is important for proper operation of the instrument.

Subheadings

On pages that describe operating procedures, the following symbols, displayed characters, and terminology are used to distinguish the procedures from their explanations:

Procedure

Follow the numbered steps. All procedures are written with inexperienced users in mind; experienced users may not need to carry out all the steps.

Explanation

This subsection describes the setting parameters and the limitations on the procedures.

Displayed Characters and Terminology Used in the Procedural Explanations

Panel Keys and Soft keys

Bold characters used in the procedural explanations indicate characters that are marked on the panel keys or the characters of the soft keys or menus displayed on the screen.

SHIFT+Panel Key

SHIFT+key means you will press the SHIFT key to turn ON the SHIFT key followed by the operation key. The setup menu marked in purple below the panel key that you pressed appears on the screen.

Unit

k Denotes 1000. Example: 12 kg, 100 kHz

K Denotes 1024. Example: 459 KB (file data size)

Contents

Safety Precautions	ii
Conventions Used in This Manual	iii

Chapter 1 Motor Evaluation Function (Motor Version)

1.1	Names and Functions of Parts of the Motor Evaluation Function	1-1
△ 1.2	Applying Signals of Rotating Speed and Torque	1-2
1.3	Selecting the Type of the Revolution and Torque Signals	1-4
1.4	Selecting the Analog Range	1-7
1.5	Selecting the Line Filter and Synchronization Source	1-10
1.6	Setting the Pulse Range, Pulse Count, and Pulse Rating	1-12
1.7	Setting the Scaling Factor and Unit	1-17
1.8	Setting the Motor and Frequency Measurement Source for Computing the Sync Speed and Slip	1-21
1.9	Computing the Motor Efficiency and Total Efficiency	1-24
1.10	Specifications of the Motor Evaluation Function	1-25

Chapter 2 Printing the Screen Image and Numeric Data List (Option)

2.1	Names and Functions of Parts of the Built-in Printer	2-1
2.2	Loading the Roll Paper and Feeding the Paper	2-2
2.3	Printing Screen Images on the Built-in Printer	2-7
2.4	Printing Numeric Data Lists on the Built-in Printer	2-9
2.5	Auto Print	2-12
2.6	Built-in Printer Specifications	2-18

Chapter 3 D/A Output and Remote Control (Option)

3.1	Part Names and Functions of D/A Output	3-1
△ 3.2	Setting the D/A Output	3-3
3.3	Setting the D/A Zoom	3-10
△ 3.4	Remote Control	3-12
3.5	D/A Output and Remote Control Specifications	3-14

Chapter 4 RGB Video Signal (VGA) Output (Option)

4.1	Names and Functions of the Parts of the RGB Video Signal (VGA) Output	4-1
4.2	RGB Video Signal (VGA) Output Specifications	4-2

Chapter 5 Ethernet Communications (Option)

5.1	Connecting to the Network	5-1
5.2	Setting TCP/IP	5-2
5.3	Saving Setup, Waveform Display, Numeric , and Image Data to the FTP Server (FTP Client Function)	5-9
5.4	Printing Screen Images on a Network Printer	5-12
5.5	Sending E-mail	5-16
5.6	Accessing the WT3000 from a PC or Workstation (FTP Server Function)	5-19
5.7	Setting of the Time Difference from GMT or SNTP	5-23
5.8	Checking the Ethernet Communication Function (Option) Availability and MAC Address	5-25
5.9	Setting the FTP Passive Mode and LPR/SMTP Timeout	5-26
5.10	Ethernet Interface Specifications	5-28

Chapter 6 Delta Computation (Option)

6.1 Delta Computation Function 6-1

6.2 Setting the Delta Computation 6-2

6.3 Determination of Delta Computation 6-5

6.4 Delta Computation Specifications 6-6

Chapter 7 Harmonic Measurement in Normal Measurement Mode (Option)

7.1 Harmonic Measurement Function 7-1

7.2 Setting the Measurement Mode and Displaying Numeric Data 7-10

7.3 Setting the Number of Displayed Items, Page Scrolling the Display 7-12

7.4 Changing the Displayed Items of Numeric Data 7-16

△ 7.5 Selecting the PLL Source 7-22

7.6 Setting the Measured Order 7-25

7.7 Selecting the Distortion Factor Equation 7-27

7.8 Setting the Anti-Aliasing Filter 7-28

7.9 Displaying the Bar Graph and Making Cursor Measurements 7-30

7.10 Displaying Vectors 7-35

7.11 Harmonic Measurement Specifications 7-38

Chapter 8 Wide Bandwidth Harmonic Measurement (Option)

8.1 Wide Bandwidth Harmonic Measurement Function 8-1

8.2 Various Settings Related to Wide Bandwidth Harmonic Measurement 8-2

8.3 Selecting the Wide Bandwidth Harmonic Measurement Mode and Displaying Numeric Data 8-3

8.4 Turning ON/OFF the Timeout Warning Display of the PLL Lock 8-5

8.5 Wide Bandwidth Harmonic Measurement Specifications 8-6

Chapter 9 IEC Harmonic Measurement (Option)

9.1 IEC Harmonic Measurement Function 9-1

9.2 Various Settings Related to IEC Harmonic Measurement 9-5

9.3 Selecting the IEC Harmonic Measurement Mode 9-6

9.4 Selecting the Measured Source 9-7

9.5 Selecting the Voltage/Current Grouping 9-8

9.6 IEC Harmonic Measurement Specifications 9-10

Chapter 10 Waveform Computation (Option)

10.1 Waveform Computation Function 10-1

10.2 Various Settings Related to Waveform Computation 10-3

10.3 Setting the Waveform Computation Mode 10-4

10.4 Setting the Waveform Equation 10-5

10.5 Setting the Scale, Unit, and Label of the Computed Waveform 10-9

10.6 Waveform Computation Function Specifications 10-13

1

2

3

4

5

6

7

8

9

10

11

12

13

Chapter 11 FFT (Option)

11.1	FFT Function	11-1
11.2	Various Settings Related to FFT	11-4
11.3	Setting the FFT Mode	11-5
11.4	Selecting the Power Spectrum to Be Displayed, Selecting the FFT Source, and Setting the Label	11-7
11.5	Setting the Number of Computed Points and Time Window	11-10
11.6	Setting the Display Range of the X-Axis (Frequency) and the Scale Type of the Y-Axis (Signal Amplitude)	11-12
11.7	Selecting the Display Type of the Power Spectrum	11-14
11.8	Displaying the Power Spectrum on the Split Screen	11-16
11.9	Cursor Measurement	11-17
11.10	FFT Function Specifications	11-20

Chapter 12 Voltage Fluctuation and Flicker Measurement (Option)

12.1	Voltage Fluctuation and Flicker Measurement Function	12-1
12.2	Setting the Voltage Fluctuation and Flicker Measurement Mode	12-5
12.3	Setting the Measurement Conditions	12-7
12.4	Setting the Judgement Conditions	12-11
12.5	Executing the Normal Voltage Fluctuation and Flicker Measurement	12-16
12.6	Executing the Measurement of dmax Caused by Manual Switching	12-23
12.7	Voltage Fluctuation and Flicker Measurement Specifications	12-30

Chapter 13 Cycle-by-Cycle Measurement (Option)

13.1	Cycle-by-Cycle Measurement Function	13-1
13.2	Setting the Cycle-by-Cycle Measurement Mode	13-4
13.3	Setting the Measurement Conditions	13-6
13.4	Executing the Cycle-by-Cycle Measurement	13-13
13.5	Cycle-by-Cycle Measurement Specifications	13-19

Index

1.1 Names and Functions of Parts of the Motor Evaluation Function

Front Panel

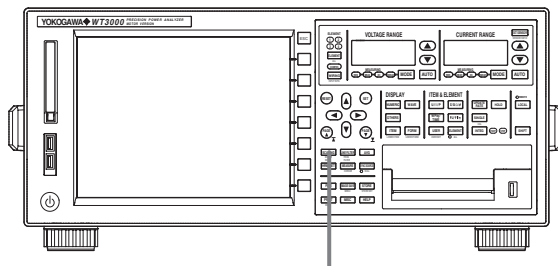

SHIFT+SCALING (MOTOR SET) key (motor version)
Sets items that are required in the motor evaluation such as torque, number of rotations, and motor output.

Rear Panel

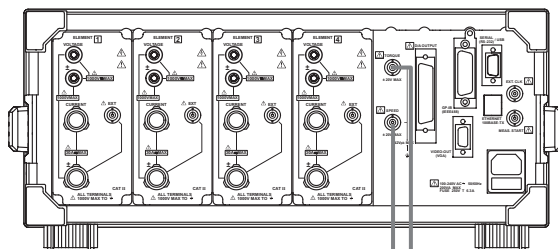

Torque signal input connector (TORQUE) (motor version)
Receives signals from torque meters when evaluating motors.

Revolution signal input connector (SPEED) (motor version)
Receives signals from revolution sensors when evaluating motors.

Functional Description

By using the motor evaluation function (motor version), the rotating speed, torque, and output of a motor can be determined from the signal that is proportional to the rotating speed of the motor, and the signal received from a torque meter, which is proportional to the motor's torque. The signal applied from the revolution sensor or torque meter to the WT3000 can be selected from analog signal (DC voltage) or pulse signal. In addition, the synchronous speed and slip of a motor can be determined by setting the motor's number of poles. Furthermore, the active power and frequency that are measured by the WT3000 and the motor output can be used to compute the motor efficiency and the total efficiency.

Types of Measurement Functions

Measurement functions consists of Speed (rotating speed), Torque, Pm (motor output or mechanical power), SyncSp (synchronous speed), and Slip. For details on the determination of the measurement functions, see section 1.10. Set equations for the motor efficiency $((P_m)/(P_{\Sigma A}) \times 100)$ and total efficiency $((P_m)/(P_{\Sigma B}) \times 100)$ according to the procedures in section 5.7 in the *User's Manual IM760301-01E*.

Limitations by Measurement Modes

Measurement functions of the motor evaluation function cannot be measured in wide bandwidth harmonic measurement, IEC harmonics measurement, voltage fluctuation and flicker measurement, and cycle-by-cycle measurement modes.

1.2 Applying Signals of Rotating Speed and Torque



CAUTION

Applying a voltage exceeding the maximum allowable input to the revolution signal input connector (SPEED) or torque signal input connector (TORQUE) can damage the instrument.

Revolution Signal Input Connector (SPEED)

Input the signal output from the revolution sensor (a DC voltage (analog signal) or a pulse signal that is proportional to the rotating speed of the motor) according to the following specifications.



• DC Voltage (Analog Input)

Item	Specifications
Connector type	Isolated BNC connector
Input range	1 V, 2 V, 5 V, 10 V, and 20 V
Effective input range	0% to $\pm 110\%$ of the measurement range
Input resistance	Approx. 1 M Ω
Maximum allowable input	± 22 V
Continuous maximum common mode voltage	± 42 V _{peak} or less

• Pulse Input

Item	Specifications
Connector type	Isolated BNC connector
Frequency range	2 Hz to 200 kHz
Amplitude input range	± 12 V _{peak}
Effective amplitude	1 V (peak to peak) or more
Input waveform	50% duty ratio rectangular wave
Input resistance	Approx. 1 M Ω
Continuous maximum common mode voltage	± 42 V _{peak} or less

Torque Signal Input Connector (TORQUE)

Input the signal output from the torque meter (a DC voltage (analog or pulse signal) that is proportional to the torque of the motor) according to the following specifications.



- **DC Voltage (Analog Input)**

Item	Specifications
Connector type	Isolated BNC connector
Input range	1 V, 2 V, 5 V, 10 V, and 20 V
Effective input range	0% to $\pm 110\%$ of the measurement range
Input resistance	Approx. 1 M Ω
Maximum allowable input	± 22 V
Continuous maximum common mode voltage	± 42 V _{peak} or less

- **Pulse Input**

Item	Specifications
Connector type	Isolated BNC connector
Frequency range	2 Hz to 200 kHz
Amplitude input range	± 12 V _{peak}
Effective amplitude	1 V (peak to peak) or more
Input waveform	50% duty ratio rectangular wave
Input resistance	Approx. 1 M Ω
Continuous maximum common mode voltage	± 42 V _{peak} or less

1.3 Selecting the Type of the Revolution and Torque Signals

Procedure

Cursor keys

RESET SET

NUMERIC WAVE

ITEM & ELEMENT

U/I/P S/Q/λ/φ

UPDATE RATE HOLD LOCAL

OTHERS

WP/q/TIME FU/FI/η

SINGLE

ITEM FORM

USER ELEMENT

INTEG START STOP SHIFT

○ REMOTE LOCAL

SCALING MOTOR SET

LINE FILTER FREQ FILTER

AVG

HRM SET MEASURE SYNC SOURCE

CURSOR ○ NULL

FILE IMAGE SAVE STORE

MENU STORE SET

PRINT MISC HELP

MENU

To exit the menu during operation, press **ESC** located above the soft keys.

In the procedural explanation below, the phrase “press the **cursor keys**” may be used. This phrase refers to the procedures for selecting items and entering values and character strings. For details on the procedures, see section 3.14 in the *User’s Manual IM760301-01E*.

1. Press **SHIFT+SCALING (MOTOR SET)** to display the Motor Set dialog box.
- **Selecting the Revolution Signal Type**
 2. Press the **cursor keys** to select the Sense Type under Speed.
 3. Press **SET**. A signal type selection box appears.
 4. Press the **cursor keys** to select Analog or Pulse.
 5. Press **SET** to confirm the signal type.

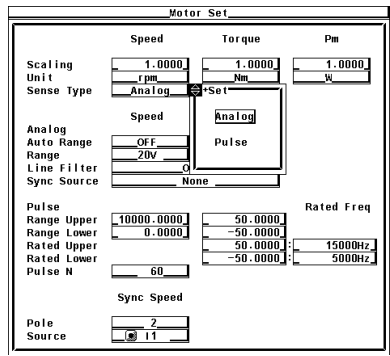

- **Selecting the Torque Signal Type**
 2. Press the **cursor keys** to select the Sense Type under Torque.
 3. Press **SET**. A signal type selection box appears.
 4. Press the **cursor keys** to select Analog or Pulse.
 5. Press **SET** to confirm the signal type.

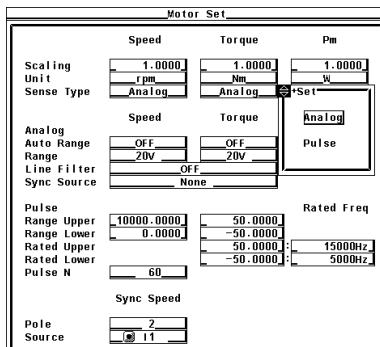

Explanation

- **Selecting the Signal Type**

The signal applied from the revolution sensor or torque meter to the WT3000 can be selected from the following two types.

 - **Analog**

Select this when the signal type is a DC voltage (analog signal).
 - **Pulse**

Select this when the signal type is a pulse signal.
- **Signal Type and Setup Items**

Some of the settings described in the subsequent sections are not required depending on the signal type as described below.

- **Settings Related to the Revolution Signal Type**

	Revolution Signal Type	
	Analog	Pulse
Analog range (section 1.4)	Required	Not required
Line filter (section 1.5)	Required	Not required
Synchronization source (section 1.5)	Required	Recommended*
Pulse range (section 1.6)	Not required	Required
Pulse count per revolution (section 1.6)	Not required	Required

* Measurement is possible using None (default), but it is recommended that you specify the setting to improve the measurement accuracy. For details, see the explanation in section 1.5.

1.3 Selecting the Type of the Revolution and Torque Signals

- **Settings Related to the Torque Signal Type**

	Torque Signal Type	
	Analog	Pulse
Analog range (section 1.4)	Required	Not required
Line filter (section 1.5)	Required	Not required
Synchronization source (section 1.5)	Required	Recommended*
Pulse range (section 1.6)	Not required	Required
Pulse rating (section 1.6)	Not required	Required

* Measurement is possible using None (default), but it is recommended that you specify the setting to improve the measurement accuracy. For details, see the explanation in section 1.5.

- **Common Settings Not Dependent on the Signal Type**

- Motor's number of poles and frequency measurement source (section 1.7)
- Scaling factor and unit (section 1.8)

1.4 Selecting the Analog Range

Procedure

Cursor keys

RESET, SET, UP, DOWN, LEFT, RIGHT, PAGE UP, PAGE DOWN

DISPLAY
 NUMERIC, WAVE, OTHERS, ITEM, FORM

ITEM & ELEMENT
 U/I/P, S/Q/A/φ, WP/q/TIME, FU/Fl/η, USER, ELEMENT, LOWER ITEM, LOWER FORM, USER SET, ALL

UPDATE RATE, HOLD, LOCAL, SINGLE, CAL, INTEG, START, STOP, SHIFT

SCALING (MOTOR SET), LINE FILTER, AVG, HRM SET, MEASURE, SYNC SOURCE, FILE, IMAGE SAVE, STORE, PRINT, MISC, HELP

To exit the menu during operation, press **ESC** located above the soft keys.

In the procedural explanation below, the phrase “press the **cursor keys**” may be used. This phrase refers to the procedures for selecting items and entering values and character strings. For details on the procedures, see section 3.14 in the *User's Manual IM760301-01E*.

The settings covered in this section apply to the case when the input signal type is set to Analog. You do not have to specify the settings in this section if the input signal type is set to Pulse.

1. Press **SHIFT+SCALING (MOTOR SET)** to display the Motor Set dialog box.
- **Selecting the Analog Input Range of the Revolution Signal**
 - **Selecting Auto Range**
 2. Press the **cursor keys** to select Auto Range under Speed.
 3. Press **SET**. An auto range selection box appears.
 4. Press the **cursor keys** to select ON or OFF.
 5. Press **SET** to confirm the auto range setting.

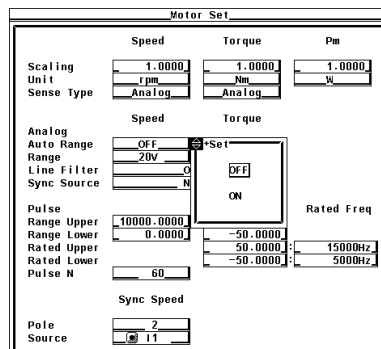

1.4 Selecting the Analog Range

- **When Measuring Using a Fixed Range (When Auto Range Is Set to OFF)**

6. Press the **cursor keys** to select Range under Speed.
7. Press **SET**. An input range selection box appears.
8. Press the **cursor keys** to select a value between 20 V to 1 V.
9. Press **SET** to confirm the input range.

The screenshot shows the 'Motor Set' menu with the following settings:

Speed	Torque	Pm
Scaling: 1.0000	Scaling: 1.0000	Scaling: 1.0000
Unit: rpm	Unit: Nm	Unit: W
Sense Type: Analog	Sense Type: Analog	
Speed: 20V	Torque: 20V	
Line Filter: OFF	Line Filter: OFF	
Sync Source: N	Sync Source: 20V	
Pulse Range Upper: 10000.0000	Pulse Range Upper: 10V	Rated Freq: 1500Hz
Pulse Range Lower: 0.0000	Pulse Range Lower: 5V	Rated Freq: 500Hz
Rated Upper: 60	Rated Lower: 2V	
Pulse N: 60	Pulse N: 1V	
Sync Speed: 2		
Pole Source: 11		

- **Selecting the Analog Input Range of the Torque Signal**

- **Selecting Auto Range**

2. Press the **cursor keys** to select Auto Range under Torque.
3. Press **SET**. An auto range selection box appears.
4. Press the **cursor keys** to select ON or OFF.
5. Press **SET** to confirm the auto range setting.

The screenshot shows the 'Motor Set' menu with the following settings:

Speed	Torque	Pm
Scaling: 1.0000	Scaling: 1.0000	Scaling: 1.0000
Unit: rpm	Unit: Nm	Unit: W
Sense Type: Analog	Sense Type: Analog	
Speed: 20V	Torque: 20V	
Line Filter: OFF	Line Filter: OFF	
Sync Source: None	Sync Source: None	
Pulse Range Upper: 10000.0000	Pulse Range Upper: 50.0000	Rated Freq: 1500Hz
Pulse Range Lower: 0.0000	Pulse Range Lower: -50.0000	Rated Freq: 500Hz
Rated Upper: 60	Rated Lower: 50.0000	
Pulse N: 60	Pulse N: -50.0000	
Sync Speed: 2		
Pole Source: 11		

- **When Measuring Using a Fixed Range (When Auto Range Is Set to OFF)**

6. Press the **cursor keys** to select Range under Torque.
7. Press **SET**. An input range selection box appears.
8. Press the **cursor keys** to select a value between 20 V to 1 V.
9. Press **SET** to confirm the input range.

The screenshot shows the 'Motor Set' menu with the following settings:

Speed	Torque	Pm
Scaling: 1.0000	Scaling: 1.0000	Scaling: 1.0000
Unit: rpm	Unit: Nm	Unit: W
Sense Type: Analog	Sense Type: Analog	
Speed: 20V	Torque: 20V	
Line Filter: OFF	Line Filter: OFF	
Sync Source: None	Sync Source: None	
Pulse Range Upper: 10000.0000	Pulse Range Upper: 50.0000	Rated Freq: 1500Hz
Pulse Range Lower: 0.0000	Pulse Range Lower: -50.0000	Rated Freq: 500Hz
Rated Upper: 60	Rated Lower: 50.0000	
Pulse N: 60	Pulse N: -50.0000	
Sync Speed: 2		
Pole Source: 11		

Explanation

- **Selecting the Input Range of the Revolution and Torque Signals**

Two types of range settings are available: fixed and auto.

- **Fixed Range**

Select the input range from the following:

20 V, 10 V, 5 V, 2 V, or 1 V

- **Auto Range**

Select ON for the auto range setting to enable auto range. The range changes automatically depending on the amplitude of the input signal.

- **Range Increase**

- When the rotating speed or torque data exceeds 110% of the current measurement range, the measurement range is increased.
- When the peak value of the input signal exceeds approximately 150% of the measurement range, the range is increased.

- **Range Decrease**

When the rotating speed or torque data is less than 30% of the measurement range and the peak value of the input signal is less than 125% of the next lower range, the measurement range is decreased.

Note

When non-periodic pulse waveforms are applied during auto range, the range may not remain constant. If this happens, use the fixed range setting.

1.5 Selecting the Line Filter and Synchronization Source

Procedure

To exit the menu during operation, press **ESC** located above the soft keys.

In the procedural explanation below, the phrase “press the **cursor keys**” may be used. This phrase refers to the procedures for selecting items and entering values and character strings. For details on the procedures, see section 3.14 in the *User’s Manual IM760301-01E*.

The settings covered in this section apply to the case when the input signal type is set to Analog. You do not have to specify the settings in this section if the input signal type is set to Pulse.

1. Press **SHIFT+SCALING (MOTOR SET)** to display the Motor Set dialog box.
- **Selecting the Line Filter**
 2. Press the **cursor keys** to select Line Filter.
 3. Press **SET**. A line filter selection box appears.
 4. Press the **cursor keys** to select a value between OFF and 50 kHz.
 5. Press **SET** to confirm the line filter. The same filter is set to both the revolution signal and the torque signal.

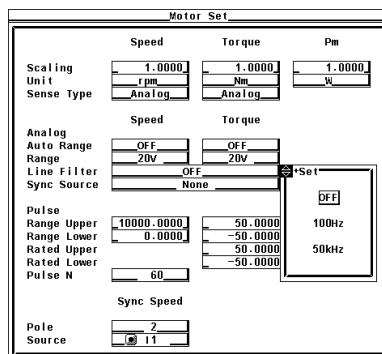

- **Selecting the Synchronization Source**
 2. Press the **cursor keys** to select Sync Source.
 3. Press **SET**. A synchronization source selection box appears.
 4. Press the **cursor keys** to select any of the elements/wiring units starting with U1.
 5. Press **SET** to confirm the synchronization source.

Explanation

- **Selecting the Line Filter**

A line filter can be inserted into the circuits that measure the revolution signal and torque signal. It eliminates harmonic noise.

The cutoff frequency can be selected from the list of choices below.

OFF, 100 Hz, and 50 kHz

Selecting OFF disables the filter.

Note

If the signal type (see section 1.3) is Pulse, the filter function does not work.

- **Line Filter and Measurement Mode**

- The line filter setting is common to all measurement modes except cycle-by-cycle measurement mode. The initial setting is OFF.

- The line filter setting in cycle-by-cycle measurement mode is independent of the setting in other measurement modes. The initial setting is 50 kHz.

- **Selecting the Synchronization Source**

- Select which element's input signal will be used as a synchronization source (synchronized to the zero-crossing point of the selected signal) when measuring the analog signal of the revolution signal and torque signal. Select the signal to be the synchronization source from the choices below. The selectable items vary depending on the installed elements.

U1, I1, U2, I2, U3, I3, U4, I4, Ext Clk (external clock)*, and None

* For the specifications of the Ext Clk (external clock), see the explanation in section 7.4.

- The measurement period determined by the synchronization source selected here is used to measure the analog signal of the revolution signal and torque signal. If you specify no synchronization source by selecting "None," the entire sampled data within the data update interval is the data used to determine the rotating speed and torque. For details on the synchronization source, see appendix 6 in the *User's Manual IM760301-01E*.

- If the rotating or torque signal is a pulse signal, the average of the pulse signal interval over the measurement period determined by the synchronization source selected here is the measured value of the rotating or torque signal. If the pulse signal interval is not within this measurement period, the measured value is determined from the previous interval.

- To achieve stable measured values by matching the measurement period with the measurement functions of voltage, current, active power, and so on such as during the measurement of the motor efficiency, it is recommended that the synchronization source be set to the same synchronization source specified in section 4.7 in the *User's Manual IM760301-01E*.

1.6 Setting the Pulse Range, Pulse Count, and Pulse Rating

Procedure

Cursor keys

DISPLAY

NUMERIC WAVE

OTHERS

ITEM FORM

LOWER ITEM LOWER FORM

ITEM & ELEMENT

U/I/P S/Q/λ/φ

WP/q/TIME FU/Fl/η

USER ELEMENT

USER SET ○ ALL

UPDATE RATE HOLD

SINGLE CAL

INTEG START STOP

○REMOTE LOCAL

SHIFT

RESET SET

PAGE PAGE

SCALING (MOTOR SET) LINE FILTER (FREQ FILTER) AVG

HRM SET MEASURE (CURSOR) SYNC SOURCE (○ NULL)

FILE IMAGE SAVE (MENU) STORE (STORE SET)

PRINT (MENU) MISC HELP

To exit the menu during operation, press **ESC** located above the soft keys.

In the procedural explanation below, the phrase “press the **cursor keys**” may be used. This phrase refers to the procedures for selecting items and entering values and character strings. For details on the procedures, see section 3.14 in the *User’s Manual IM760301-01E*.

The settings covered in this section apply to the case when the input signal type is set to Analog. You do not have to specify the settings in this section if the input signal type is set to Pulse.

1. Press **SHIFT+SCALING (MOTOR SET)** to display the Motor Set dialog box.
- **Setting the Pulse Input Range of the Revolution Signal**

If the revolution signal type is Pulse, set the upper and lower limits of the pulse input range.

 2. Press the **cursor keys** to select Pulse Range Upper under Speed.
 3. Press **SET**. A pulse input range setup box appears.
 4. Press the **cursor keys** to set the upper limit of the pulse input range.
 5. Press **SET** or **ESC** to close the box.
 6. Press the **cursor keys** to select Pulse Range Lower under Speed.
 7. Press **SET**. A pulse input range setup box appears.
 8. Press the **cursor keys** to set the lower limit of the pulse input range.
 9. Press **SET** or **ESC** to close the box.

Motor Set

	Speed	Torque	Pm
Scaling	1.0000	1.0000	1.0000
Unit	rpm	Nm	W
Sense Type	Pulse	Pulse	
Analog			
Auto Range	OFF	OFF	
Range	20V	20V	
Line Filter	OFF		
Sync Source	None		
Pulse			
Range Upper	10000.0000	50.0000	Rated Freq
Range Lower	0.0000	-50.0000	
Rated Upper		50.0000	15000Hz
Rated Lower		-50.0000	5000Hz
Pulse N	60		
Sync Speed			
Pole	2		
Source	11		

→

Motor Set

	Speed	Torque	Pm
Scaling	1.0000	1.0000	1.0000
Unit	rpm	Nm	W
Sense Type	Pulse	Pulse	
Analog			
Auto Range	OFF	OFF	
Range	20V	20V	
Line Filter	OFF		
Sync Source	None		
Pulse			
Range Upper	10000.0000	50.0000	Rated Freq
Range Lower		-50.0000	
Rated Upper		50.0000	15000Hz
Rated Lower		-50.0000	5000Hz
Pulse N	60		
Sync Speed			
Pole	2		
Source	11		

• **Setting the Pulse Input Range of the Torque Signal**

If the torque signal type is Pulse, set the upper and lower limits of the pulse input range.

2. Press the **cursor keys** to select Pulse Range Upper under Torque.
3. Press **SET**. A pulse input range setup box appears.
4. Press the **cursor keys** to set the upper limit of the pulse input range.
5. Press **SET** or **ESC** to close the box.
6. Press the **cursor keys** to select Pulse Range Lower under Torque.
7. Press **SET**. A pulse input range entry box appears.
8. Press the **cursor keys** to set the lower limit of the pulse input range.
9. Press **SET** or **ESC** to close the box.

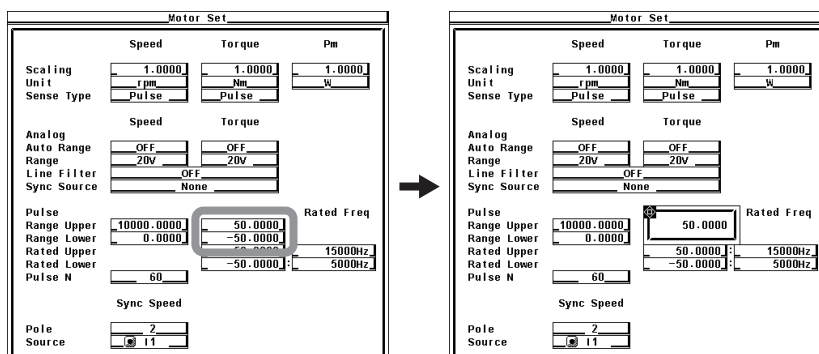

• **Setting the Pulse Count per Revolution of the Revolution Signal**

2. Press the **cursor keys** to select Pulse N.
3. Press **SET**. A pulse count entry box appears.
4. Press the **cursor keys** to set the pulse count.
5. Press **SET** or **ESC** to close the box.

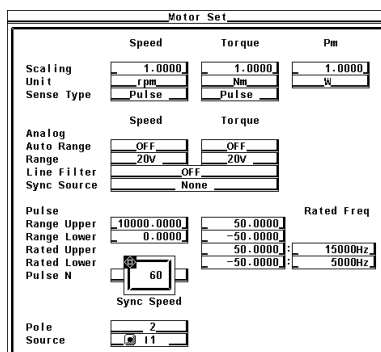

1.6 Setting the Pulse Range, Pulse Count, and Pulse Rating

- **Setting the Pulse Rating of the Torque Signal**

Set the pulse rating of the torque sensor.

- **Setting the Positive Rating**

2. Press the **cursor keys** to select Pulse Rated Upper under Torque.
3. Press **SET**. A pulse rating (torque) entry box appears.
4. Press the **cursor keys** to set the positive pulse rating (torque).
5. Press **SET** or **ESC** to close the box.
6. Press the **cursor keys** to select Rated Upper under Rated Freq under Torque.
7. Press **SET**. A pulse rating (pulse frequency) entry box appears.
8. Press the **cursor keys** to set the positive pulse rating (pulse frequency).
9. Press **SET** or **ESC** to close the box.

- **Setting the Negative Rating**

2. Press the **cursor keys** to select Pulse Rated Lower under Torque.
3. Press **SET**. A pulse rating (torque) entry box appears.
4. Press the **cursor keys** to set the negative pulse rating (torque).
5. Press **SET** or **ESC** to close the box.
6. Press the **cursor keys** to select Rated Lower under Rated Freq under Torque.
7. Press **SET**. A pulse rating (pulse frequency) entry box appears.
8. Press the **cursor keys** to set the positive pulse rating (pulse frequency).
9. Press **SET** or **ESC** to close the box.

The figure illustrates the configuration of pulse ratings for torque through three sequential screenshots of the 'Motor Set' menu. The menu is organized into sections: Scaling, Analog, Pulse, and Sync Speed. The 'Pulse' section is the primary focus, containing sub-sections for Speed and Torque, and a 'Rated Freq' section.

Screenshot 1 (Left): Shows the initial configuration. Under 'Pulse', 'Pulse Rated Upper' is set to 10000.0000 and 'Pulse Rated Lower' is 0.0000. Under 'Rated Freq', 'Rated Upper' is 50.0000 Hz and 'Rated Lower' is -50.0000 Hz. The 'Torque' sense type is 'Pulse'.

Screenshot 2 (Middle): An arrow points from the first screenshot to this one. The 'Pulse Rated Upper' value has been changed to 50.0000. The 'Rated Upper' value is now highlighted, indicating it is the next parameter to be set.

Screenshot 3 (Bottom): A downward arrow points from the second screenshot to this one. The 'Rated Upper' value has been changed to 15000Hz. The 'Rated Lower' value remains at -50.0000 Hz.

Explanation

- **Pulse Input Range**

Set an appropriate range that includes the maximum and minimum values of the input signal. For example, if you are measuring a signal whose rotating speed is between 120 rpms and 180 rpms and the torque is between $-18 \text{ N}\cdot\text{m}$ to $+18 \text{ N}\cdot\text{m}$, set the pulse input range of the rotating speed to 100 rpms to 200 rpms and that of the torque to $-20 \text{ N}\cdot\text{m}$ to $+20 \text{ N}\cdot\text{m}$.

The selectable range of pulse range of input signals is as follows:

- Revolution signal: 0.0001 to 99999.9999 [rpm]
- Torque signal: -10000.0000 to 10000.0000 [$\text{N}\cdot\text{m}$]

If the input signal type is Pulse, the upper and lower limits of the waveform display are set to the values specified here.

- On models with the D/A output (option), the rated value of the D/A output is as follows.

Input Signal of Rotating Speed or Torque	D/A Output
Pulse Range Upper setting	+5 V
Pulse Range Upper setting $\times (-1)$	-5 V

- **Setting the Rotation Pulse Count**

Set the pulse count per rotation. Set the value in the range of 1 to 9999.

$$\text{Rotating Speed} = \frac{\text{Input pulse count from the revolution sensor per minute}}{\text{Pulse count (pulse count per revolution)}} \times \text{scaling factor}^*$$

- * If the scaling factor is 1, the rotating speed is the number of rotations per minute (min^{-1} or rpm). In addition, if the revolution signal is a changed signal, you can set the scaling factor (see section 1.7) to determine the rotating speed before the change.

- **Pulse Rating of the Torque Signal**

If the torque signal type is Pulse, set the positive and negative ratings of the torque sensor. Refer to the torque sensor specifications to set the values.

The selectable range of the values is as follows:

- Torque: -10000.0000 to 10000.0000 [$\text{N}\cdot\text{m}$]
- Pulse count: 1 to 100000000 [Hz]

$$\text{Torque} = (\text{torque pulse coefficient}^{*1} \times \text{pulse frequency} + \text{torque pulse offset}^{*1}) \times \text{scaling factor}^{*2}$$

- *1 The torque pulse count and torque pulse offset are set as shown in the figure on the next page depending on the pulse rating of the torque signal.

- *2 If the torque signal is a changed signal, you can set the scaling factor (see section 1.7) to determine the torque before the change.

1.6 Setting the Pulse Range, Pulse Count, and Pulse Rating

- Relationship between the Pulse Input Range and Pulse Rating of the Torque Signal**

If the torque sensor with the specifications below is used to measure the torque in the range of -20 N-m to $+20$ N-m, the pulse input range and pulse rating settings are as shown in the screen example below.

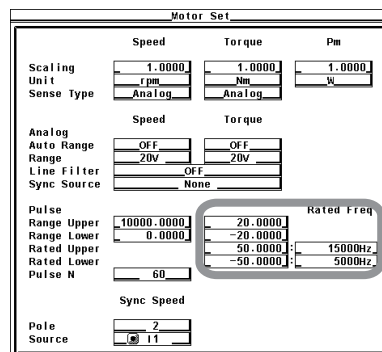
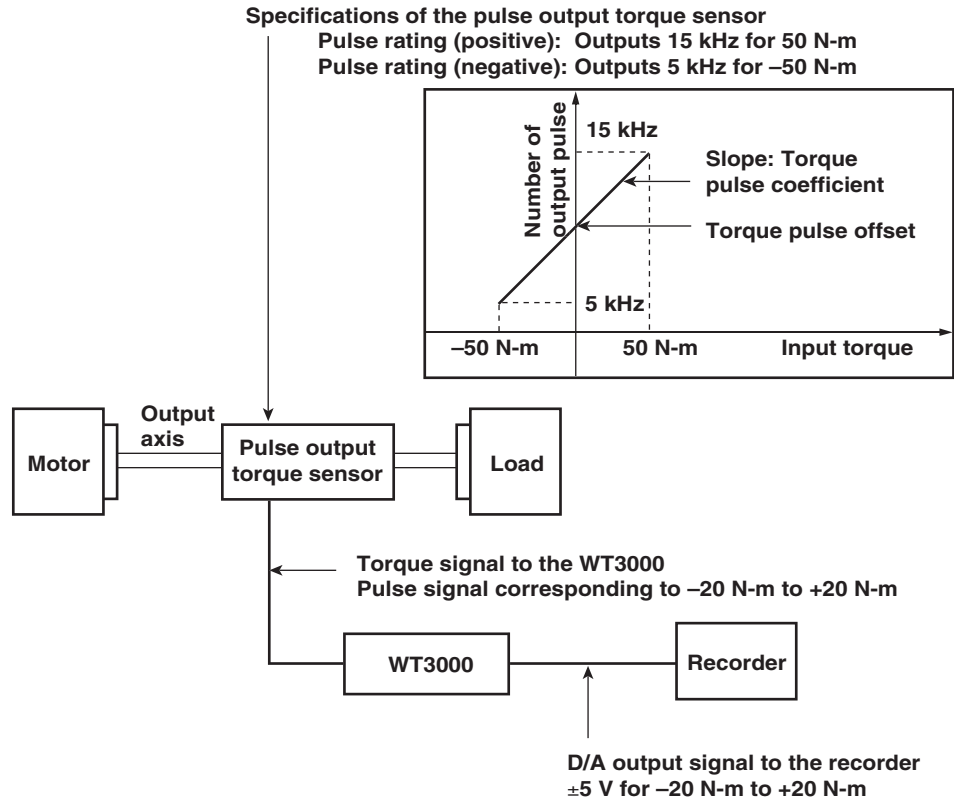

Pulse input range and pulse rating settings of the torque signal

1.7 Setting the Scaling Factor and Unit

Procedure

To exit the menu during operation, press **ESC** located above the soft keys.

In the procedural explanation below, the phrase “press the **cursor keys**” may be used. This phrase refers to the procedures for selecting items and entering values and character strings. For details on the procedures, see section 3.14 in the *User’s Manual IM760301-01E*.

1. Press **SHIFT+SCALING (MOTOR SET)** to display the Motor Set dialog box.
- **Setting the Scaling Factor Used to Transform the Revolution Signal**
 2. Press the **cursor keys** to select Scaling under Speed.
 3. Press **SET**. A scaling factor entry box appears.
 4. Press the **cursor keys** to set the scaling factor.
 5. Press **SET** or **ESC** to close the box.

1.7 Setting the Scaling Factor and Unit

- **Setting the Unit of Rotating Speed**

2. Press the **cursor keys** to select Unit under Speed.
3. Press **SET**. A keyboard appears.
4. Use the **keyboard** to set the unit.

For keyboard operations, see section 3.14 in the *User's Manual IM760301-01E*.

The screenshot shows the 'Motor Set' menu with three columns: Speed, Torque, and Pm. Under Speed, the 'Unit' is set to 'rpm'. A keyboard overlay is visible, showing the 'r' key highlighted. Other settings include Scaling factors of 1.0000, Sense Type 'Pulse', and various range and pulse parameters.

- **Setting the Scaling Factor Used to Transform the Torque Signal**

2. Press the **cursor keys** to select Scaling under Torque.
3. Press **SET**. A scaling factor entry box appears.
4. Press the **cursor keys** to set the scaling factor.
5. Press **SET** or **ESC** to close the box.

The first screenshot shows the 'Motor Set' menu with the 'Scaling' factor for Torque highlighted. An arrow points to the second screenshot, which shows the 'Scaling' factor for Torque set to '1.0000'. The 'Sense Type' for Torque is also set to 'Analog'.

- **Setting the Unit of Torque**

2. Press the **cursor keys** to select Unit under Torque.
3. Press **SET**. A keyboard appears.
4. Use the **keyboard** to set the unit.

For keyboard operations, see section 3.14 in the *User's Manual IM760301-01E*.

The screenshot shows the 'Motor Set' menu with the 'Unit' for Torque set to 'Nm'. A keyboard overlay is visible, showing the 'N' key highlighted. Other settings include Scaling factors of 1.0000, Sense Type 'Pulse', and various range and pulse parameters.

- **Setting the Scaling Factor Used to Compute the Motor Output**
 2. Press the **cursor keys** to select Scaling under Pm.
 3. Press **SET**. A scaling factor entry box appears.
 4. Press the **cursor keys** to set the scaling factor.
 5. Press **SET** or **ESC** to close the box.

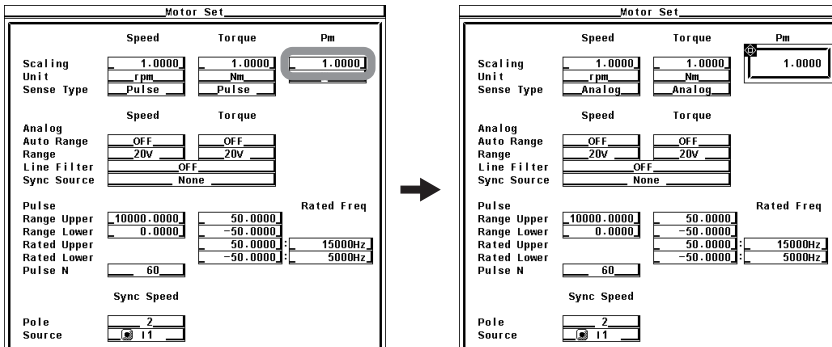

- **Setting the Unit of Motor Output**
 2. Press the **cursor keys** to select Unit under Pm.
 3. Press **SET**. A keyboard appears.
 4. Use the **keyboard** to set the unit.

For keyboard operations, see section 3.14 in the *User's Manual IM760301-01E*.

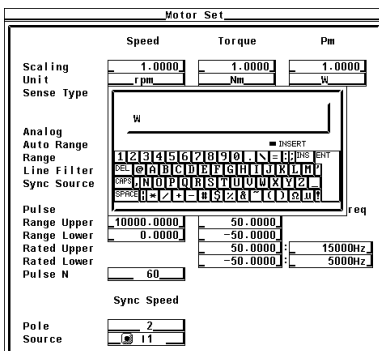

Explanation

- **Setting the Scaling Factor Used to Transform the Revolution Signal**

Set the factor used to transform the revolution signal. Set the value in the range of 0.0001 to 99999.9999.
- **When the Revolution Signal Type is Analog**

By setting the number of rotations per volt of input voltage, the rotating speed is derived from the following equation.

$$\text{Rotating speed} = \text{Input voltage from the revolution sensor} \times \text{scaling factor}$$
- **When the Revolution Signal Type is Pulse**

The value is used as a scaling factor in the equation given in “Setting the Rotation Pulse Count” in section 1.6
- **Setting the Scaling Factor Used to Transform the Torque Signal**

You can specify the scaling factor used to transform the torque signal to the torque of the motor. Set the value in the range of 0.0001 to 99999.9999.
- **When the Torque Signal Type is Analog**

By setting the torque per volt of input voltage, the torque is derived from the input voltage from the torque meter using the following equation.

$$\text{Torque} = \text{Input voltage from the torque meter} \times \text{scaling factor}$$
- **When the Torque Signal Type is Pulse**

The value is used as a scaling factor in the equation given in “Setting the Torque Signal Pulse Count” in section 1.6
- **Setting the Scaling Factor Used to Compute the Motor Output**

You can specify the scaling factor used to compute the motor output (mechanical power) from the rotating speed and torque. Set the value in the range of 0.0001 to 99999.9999.

The equation is indicated below. The scaling factors of the rotating speed and torque are set so that the unit of the rotating speed is min^{-1} (or rpm) and the unit of torque is N-m. When the scaling factor of the motor output specified here is 1, the unit of the motor output P_m is W. Because the efficiency in section 1.9 is computed with the unit of P_m to be W, it is recommended that the scaling factor of each item be set so that the unit of P_m is W.

$$\text{Motor output } P_m = \frac{2 \times \pi \times \text{rotating speed}^{*1}}{60} \times \text{scaling factor} \times \text{torque}^{*2}$$

*1 Rotating speed derived in section 1.6.
*2 Torque derived in section 1.6.
- **Setting the Unit of Rotating Speed, Torque, and Motor Output**
 - **Number of Characters**

Eight characters or less.
 - **Types of Characters**

Characters that are displayed on the keyboard or spaces.

1.8 Setting the Motor and Frequency Measurement Source for Computing the Sync Speed and Slip

Procedure

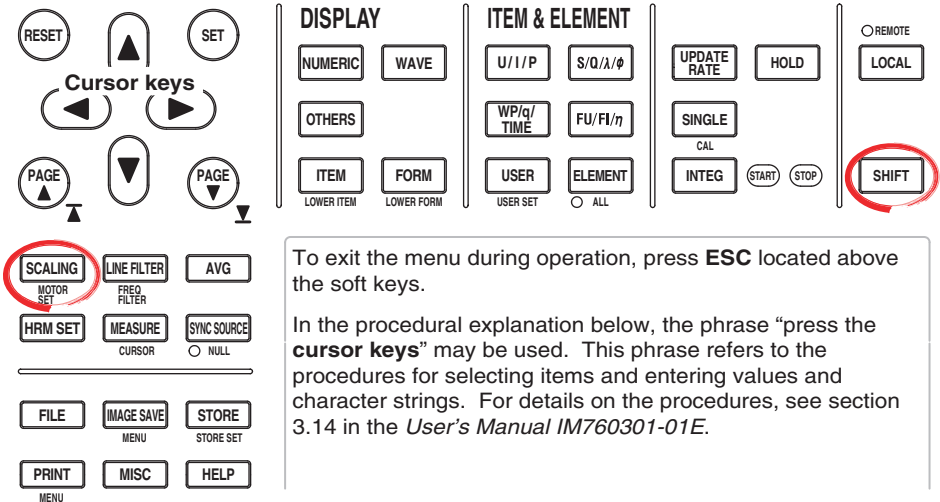

1. Press **SHIFT+SCALING (MOTOR SET)** to display the Motor Set dialog box.

- **Setting the Motor’s Number of Poles**
- 2. Press the **cursor keys** to select Pole.
- 3. Press **SET**. A box for entering the number of poles appears.
- 4. Press the **cursor keys** to set the number of poles.
- 5. Press **SET** or **ESC** to close the box.

Motor Set			
	Speed	Torque	Pm
Scaling	1.0000	1.0000	1.0000
Unit	rpm	Nm	W
Sense Type	Analog	Analog	
Analog			
Auto Range	OFF	OFF	
Range	20V	20V	
Line Filter	OFF		
Sync Source	None		
Pulse			
Range Upper	10000.0000	50.0000	Rated Freq
Range Lower	0.0000	-50.0000	
Rated Upper		50.0000	15000Hz
Rated Lower		-50.0000	5000Hz
Pulse N	60		
Sync Speed			
Pole	2		
Source			

1.8 Setting the Motor and Frequency Measurement Source for Computing the Sync Speed and Slip

- **Selecting the Frequency Measurement Source Signal (Voltage or Current Signal Supplied to the Motor)**

2. Press the **cursor keys** to select Sync Speed Source.
3. Press **SET**. A frequency measurement source selection box appears.
4. Press the **cursor keys** to select any of the target input signals for frequency measurement (see section 5.3 in the *User's Manual IM760301-01E*).

When the button to the left of the input signal in the selection box is highlighted, that is the source input signal for frequency measurement selected in section 5.3 in the *User's Manual IM760301-01E*.

5. Press **SET** to confirm the frequency measurement source.

Explanation

- **Setting the Motor's Number of Poles**

The number can be set in the range of 1 to 99. Sets the number of poles for the motor being measured.

- **Setting the Frequency Measurement Source Signal**

- Select the frequency measurement source from the choices below. The selectable items vary depending on the installed elements.
U1, I1, U2, I2, U3, I3, U4, and I4
- Select any of the source input signals for frequency measurement. When the button to the left of the input signal in the frequency measurement source selection box is highlighted, that is the source input signal for frequency measurement selected in section 5.3 in the *User's Manual IM760301-01E*. If you select an input signal that is not a frequency measurement source, an error results.
- In normal cases, the frequency measurement source (see section 5.3 in the *User's Manual IM760301-01E*) is set to the voltage or current supplied to the motor. If a frequency other than that of the voltage and current supplied by the motor is specified, the synchronous speed may not be determined correctly.

- **Equation for Deriving the Synchronous Speed**

The unit of synchronous speed is fixed to min^{-1} (or rpm). The equation is indicated below.

$$\text{Rotating speed SyncSp } (\text{min}^{-1}) = \frac{120 \times \text{frequency of the frequency measurement source (Hz)}}{\text{Motor's number of poles}}$$

1.8 Setting the Motor and Frequency Measurement Source for Computing the Sync Speed and Slip

- **Equation for Deriving the Slip**

The unit of synchronous speed is fixed to min^{-1} (or rpm). Therefore, to determine the slip, set the scaling coefficient of the rotating speed (see section 1.7) so that the unit of rotating speed is also min^{-1} (or rpm).

$$\text{Slip (\%)} = \frac{\text{Synchronous speed (min}^{-1}) - \text{rotating speed}^*(\text{min}^{-1})}{\text{Rotating speed (min}^{-1})} \times 100$$

* Rotating speed derived in section 1.6.

Note

Please select a stable voltage or current (supplied by the motor) with small distortion or noise for the frequency measurement source.

1.9 Computing the Motor Efficiency and Total Efficiency

From the active power that the WT3000 measures and the motor output determined in section 1.7, the WT3000 can compute the motor efficiency (the ratio of the motor output versus the power consumption by the motor) and total efficiency*. Set the equation according to the procedures given in section 5.7 or 5.4 in the *User's Manual IM760301-01E*. Computation examples are indicated below.

* The ratio of the motor output versus the power consumption by the motor as well as the converter through which power is fed to the motor.

When the Motor Input Is Wired to ΣA

$$\text{Motor efficiency (\%)} = \frac{\text{Motor output } P_m^*(W)}{P_{\Sigma A}(W)} \times 100$$

* Motor output P_m derived in section 1.7.

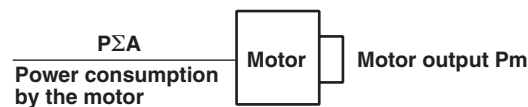

When the Converter and Motor Inputs Are Wired to ΣA and ΣB , Respectively

$$\text{Motor efficiency (\%)} = \frac{\text{Motor output } P_m^*(W)}{P_{\Sigma B}(W)} \times 100$$

$$\text{Total efficiency (\%)} = \frac{\text{Motor output } P_m^*(W)}{P_{\Sigma A}(W)} \times 100$$

* Motor output P_m derived in section 1.7.

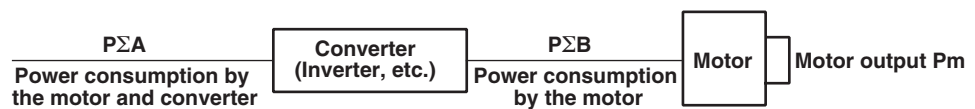

When the Converter and Motor Inputs Are Wired to ΣB and ΣA , Respectively

$$\text{Motor efficiency (\%)} = \frac{\text{Motor output } P_m^*(W)}{P_{\Sigma A}(W)} \times 100$$

$$\text{Total efficiency (\%)} = \frac{\text{Motor output } P_m^*(W)}{P_{\Sigma B}(W)} \times 100$$

* Motor output P_m derived in section 1.7.

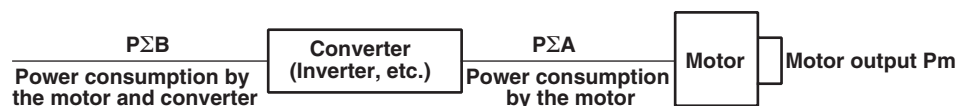

Note

If ΣA or ΣB is a three-phase, three-wire (3P3W) system, the delta computation function (see chapter 6) can be used to make a 3P3W>3V3A transformation of ΣA or ΣB . From the 3P3W>3V3A transformation, you can determine one set of line voltage and common mode current that is not being measured.

1.10 Specifications of the Motor Evaluation Function

Input Signal

Item	Specifications																		
Rotating signal and torque signal	<ul style="list-style-type: none"> For DC voltage (analog input) 																		
	<table border="1"> <thead> <tr> <th>Item</th> <th>Specifications</th> </tr> </thead> <tbody> <tr> <td>Connector type</td> <td>Isolated BNC connector</td> </tr> <tr> <td>Input range</td> <td>1 V, 2 V, 5 V, 10 V, and 20 V</td> </tr> <tr> <td>Effective input range</td> <td>0% to $\pm 110\%$ of the measurement range</td> </tr> <tr> <td>Input resistance</td> <td>Approx. 1 MΩ</td> </tr> <tr> <td>Maximum allowable input</td> <td>± 22 V</td> </tr> <tr> <td>Continuous maximum common mode voltage</td> <td>± 42 V_{peak} or less</td> </tr> <tr> <td>Accuracy</td> <td>$\pm(0.1\%$ of reading + 0.1% of range)</td> </tr> <tr> <td>Temperature coefficient</td> <td>$\pm 0.03\%$ of range/$^{\circ}$C</td> </tr> </tbody> </table>	Item	Specifications	Connector type	Isolated BNC connector	Input range	1 V, 2 V, 5 V, 10 V, and 20 V	Effective input range	0% to $\pm 110\%$ of the measurement range	Input resistance	Approx. 1 M Ω	Maximum allowable input	± 22 V	Continuous maximum common mode voltage	± 42 V _{peak} or less	Accuracy	$\pm(0.1\%$ of reading + 0.1% of range)	Temperature coefficient	$\pm 0.03\%$ of range/ $^{\circ}$ C
Item	Specifications																		
Connector type	Isolated BNC connector																		
Input range	1 V, 2 V, 5 V, 10 V, and 20 V																		
Effective input range	0% to $\pm 110\%$ of the measurement range																		
Input resistance	Approx. 1 M Ω																		
Maximum allowable input	± 22 V																		
Continuous maximum common mode voltage	± 42 V _{peak} or less																		
Accuracy	$\pm(0.1\%$ of reading + 0.1% of range)																		
Temperature coefficient	$\pm 0.03\%$ of range/ $^{\circ}$ C																		
	<ul style="list-style-type: none"> For pulse input 																		
	<table border="1"> <thead> <tr> <th>Item</th> <th>Specifications</th> </tr> </thead> <tbody> <tr> <td>Connector type</td> <td>Isolated BNC connector</td> </tr> <tr> <td>Frequency range</td> <td>2 Hz to 200 kHz</td> </tr> <tr> <td>Amplitude input range</td> <td>± 12 V_{peak}</td> </tr> <tr> <td>Effective amplitude</td> <td>1 V (peak-to-peak) or more</td> </tr> <tr> <td>Input waveform</td> <td>50% duty ratio rectangular wave</td> </tr> <tr> <td>Input resistance</td> <td>Approx. 1 MΩ</td> </tr> <tr> <td>Continuous maximum common mode voltage</td> <td>± 42 V_{peak} or less</td> </tr> <tr> <td>Accuracy</td> <td>$\pm(0.05\%$ of reading + 1 mHz)</td> </tr> </tbody> </table>	Item	Specifications	Connector type	Isolated BNC connector	Frequency range	2 Hz to 200 kHz	Amplitude input range	± 12 V _{peak}	Effective amplitude	1 V (peak-to-peak) or more	Input waveform	50% duty ratio rectangular wave	Input resistance	Approx. 1 M Ω	Continuous maximum common mode voltage	± 42 V _{peak} or less	Accuracy	$\pm(0.05\%$ of reading + 1 mHz)
Item	Specifications																		
Connector type	Isolated BNC connector																		
Frequency range	2 Hz to 200 kHz																		
Amplitude input range	± 12 V _{peak}																		
Effective amplitude	1 V (peak-to-peak) or more																		
Input waveform	50% duty ratio rectangular wave																		
Input resistance	Approx. 1 M Ω																		
Continuous maximum common mode voltage	± 42 V _{peak} or less																		
Accuracy	$\pm(0.05\%$ of reading + 1 mHz)																		

Measurement Function

Item	Symbol and Meaning
Rotating speed	Speed: Motor's rotating speed
Torque	Torque: Motor's torque
Synchronous speed	SyncSp
Slip (%)	Slip
Motor output	Pm: Motor's mechanical output (mechanical power)

For the default values and displayed order of numeric data, see appendix 3 in the *User's Manual IM760301-01E*.

Symbols and Determination of Motor Evaluation Measurement Functions

Measurement Functions during Normal Measurement		Method of Determination, Equation
Motor evaluation	Rotating speed	<p>When the type of input signal from the revolution sensor is DC voltage (analog signal) Input voltage from the revolution sensor • Scaling factor Scaling factor: Number of rotations per volt of input voltage</p> <p>When the type of input signal from the revolution sensor is pulse count $\frac{\text{Number of input pulses from the revolution sensor per minute}}{\text{Number of pulses per rotation}} \cdot \text{Scaling factor}$ Scaling factor: When the signal of the gear ratio or revolution sensor is a converted signal, you can specify the gear ratio for the scaling factor to determine the rotating speed before the gear change.</p>
	Torque	<p>When type of input signal from the torque meter is DC voltage (analog signal) Scaling factor • input voltage from the torque meter Scaling factor: torque per volt of input voltage</p> <p>When the type of input signal from the torque meter is pulse (Torque pulse coefficient • pulse frequency + torque pulse offset) • scaling factor Torque pulse coefficient and torque pulse offset: Calculated in the WT3000 from the torque values [N-m] at two points corresponding to the upper and lower limits of frequency. Scaling factor: Normally, use the value of 1. When using a unit other than N-m, set the conversion ratio of the unit.</p>
	Synchronous speed	<p>$\frac{120 \cdot \text{Frequency of the frequency measurement source (Hz)}}{\text{Motor's number of poles}}$</p> <ul style="list-style-type: none"> • The unit of synchronized speed is fixed to “min⁻¹ (or rpm).” • Normally, the frequency measurement source is set to the voltage or current that is supplied to the motor. The synchronized speed may not be determined correctly if a different signal is specified.
	Slip [%]	$\frac{\text{SyncSp} - \text{Speed}}{\text{SyncSp}} \cdot 100$
	Motor output Pm	$\frac{2 \pi \cdot \text{Speed} \cdot \text{Torque}}{60} \cdot \text{Scaling factor}$ <p>When the unit of speed is “min⁻¹ (or rpm),” the unit of torque is “N-m,” and the scaling factor is 1, the unit of motor output Pm is “W.”</p>

Set the efficiency equation or user-defined function to determine the motor efficiency and total efficiency.

2.1 Names and Functions of Parts of the Built-in Printer

Front Panel

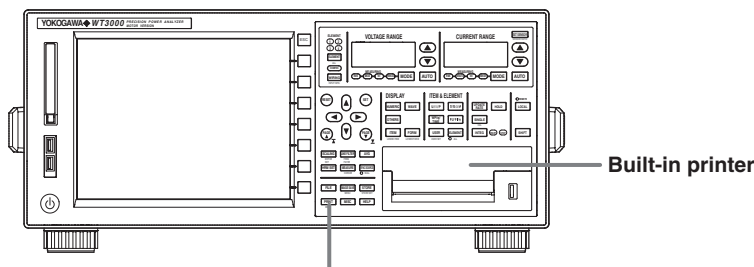

PRINT key
Prints the screen image data or numeric data list.

SHIFT+PRINT (MENU) key
Feeds the paper and sets the screen image data and numeric data list printing.

Functional Description

Screen images and numeric data list can be printed on the built-in printer. Comments can be inserted in the screen images.

- * For the procedure to print the screen image on a network printer, see section 5.4. The numeric data list cannot be printed on a network printer.

When auto print is used, screen images and numeric data lists can be printed automatically on the built-in printer at the specified print interval. In addition, you can print screen images and numeric data at the desired time by setting the reservation time for auto print start/stop. Printing is also possible by synchronizing to the integration time.

	Output Format		Auto Print
	Screen Image	Numeric List	
Built-in printer	Yes	Yes	Yes
Network printer	Yes	No	No

Yes: Printing is possible.

No: Printing is not possible.

2.2 Loading the Roll Paper and Feeding the Paper

WARNING

A roll paper cutter is attached to the printer unit cover. Be careful not to injure your hand or fingers on the cutter.

- Do not insert your finger into the printer unit opening where the roll paper is fed out.
- Do not let your hand or fingers come in contact with the cutter when opening the printer unit cover and loading the roll paper in the holder.

Procedure

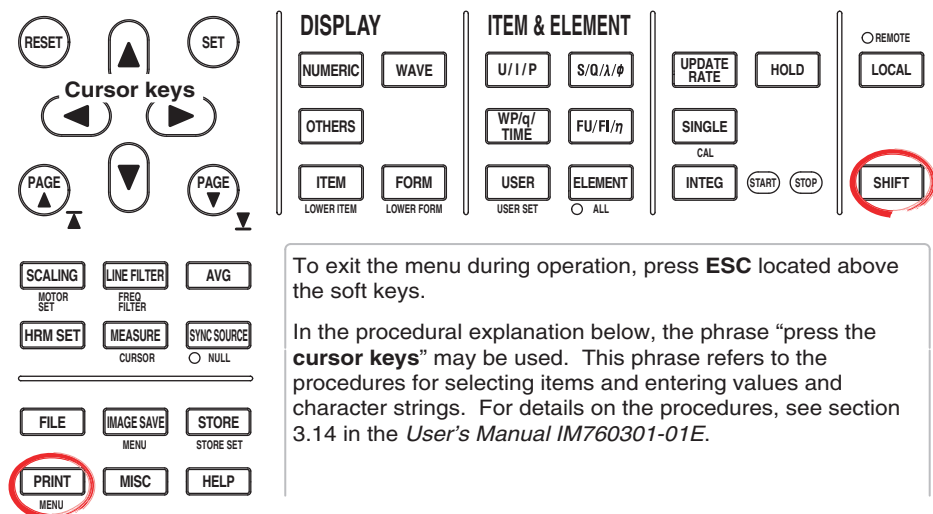

• Loading the Roll Paper

1. Slide the lever to the right. The printer unit comes out.

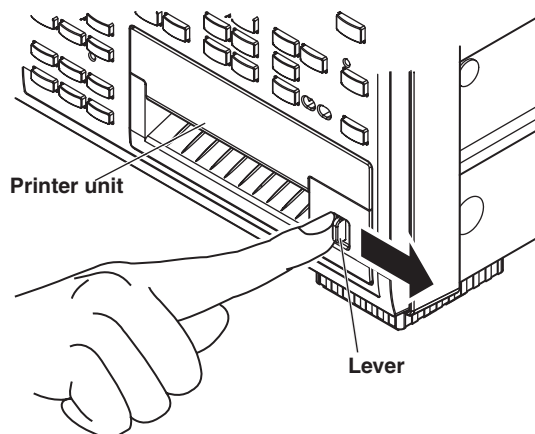

- 2. Hook your finger in the groove on the right side of the printer unit.

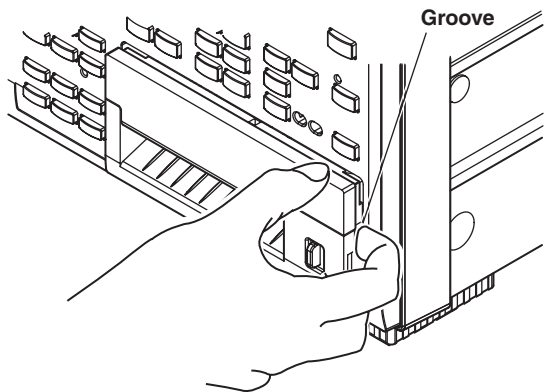

- 3. Hold the top, bottom, and right sections of the printer unit and pull the printer unit out until it stops (approximately 5 cm).

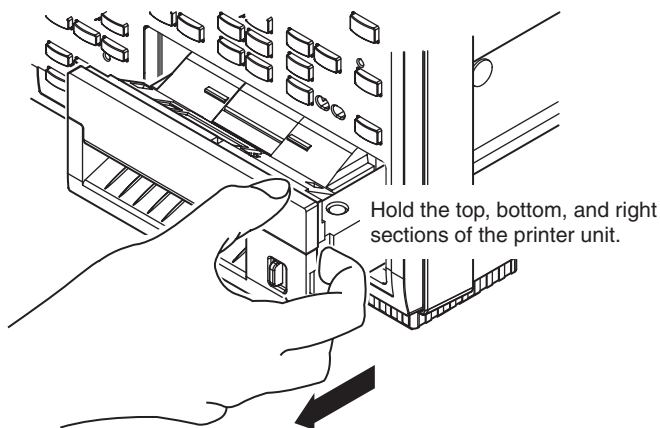

- 4. While holding the left and right sides of the tray with your hands, pull up both sides of the front cover of the printer unit with your thumbs.

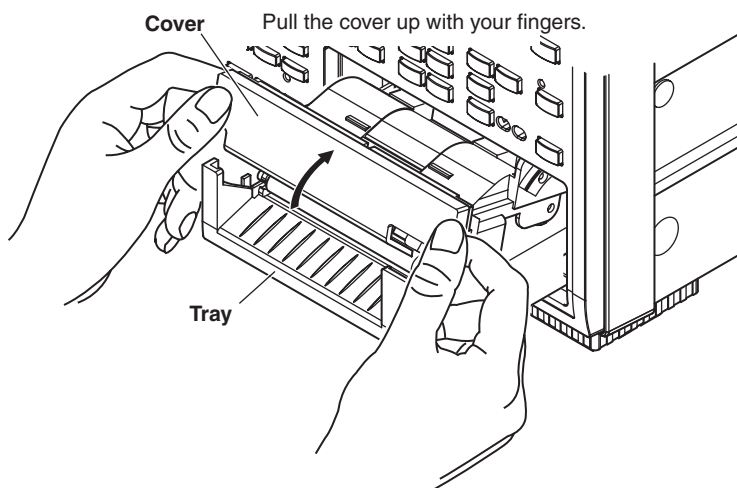

2.2 Loading the Roll Paper and Feeding the Paper

5. With approximately 10 cm of the paper unrolled, load the roll paper in the holder with the thermal-sensitive side facing up. Load the roll paper so that it fits into the guide.

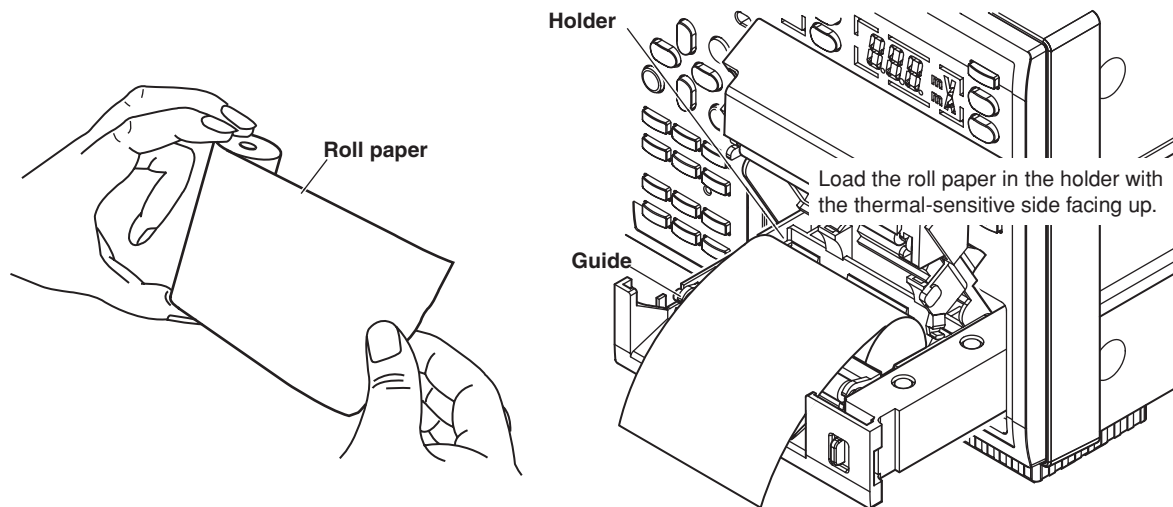

6. While pressing the stopper to the left so that the latch is disengaged, lower the cover. Support the tray from the bottom with both hands, and close the cover until it clicks in place.

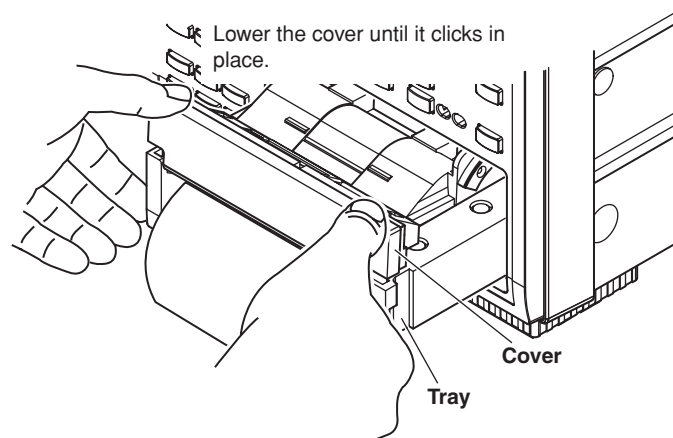
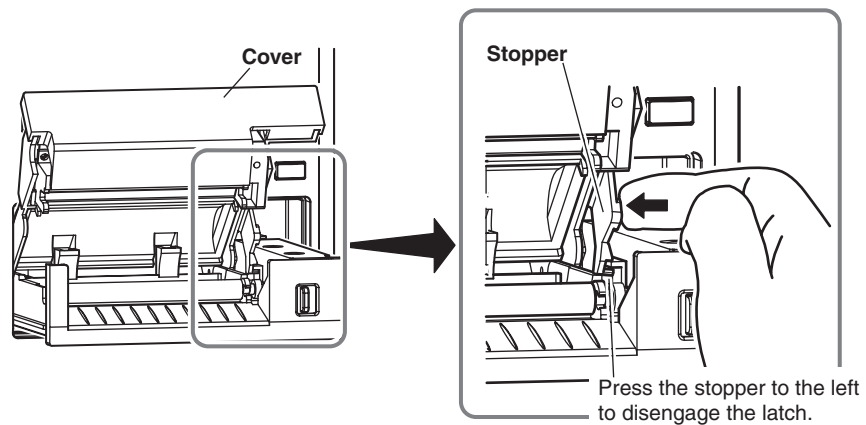

7. Placing your thumb on the front panel (left of the lever) of the printer, push the printer unit in until it clicks in place.

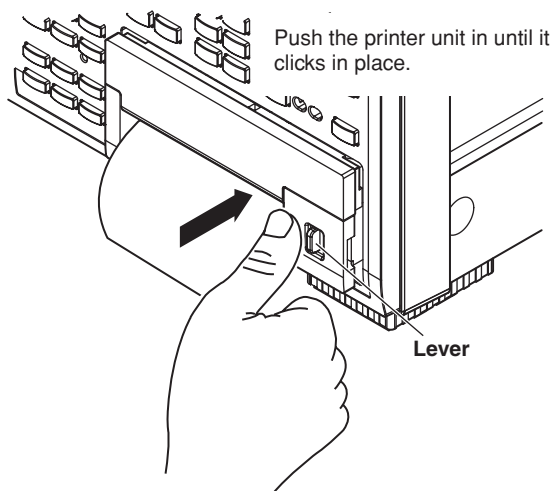

This completes the loading of roll paper.

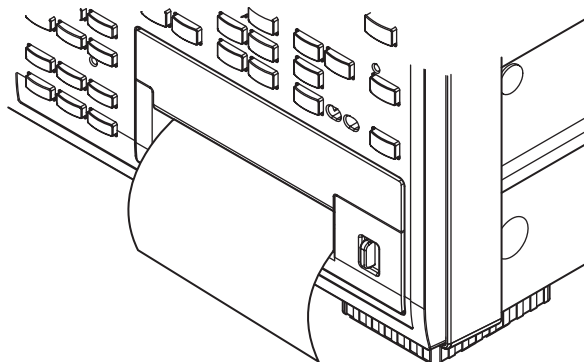

• **Feeding the Paper**

1. Press **SHIFT+PRINT (MENU)** to display the Print menu.
2. Press the **Paper Feed** soft key. Each time the soft key is pressed, the roll paper is fed approximately 3 cm.

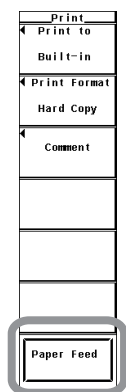

• **Cutting the Roll Paper**

To cut the paper after the paper roll is loaded and the printer cover is closed or after printing the measured data, pull the roll paper upward against the cover.

2.2 Loading the Roll Paper and Feeding the Paper

Explanation

- **Printer Roll Paper**

Use only the dedicated roll paper provided by YOKOGAWA. Do not use other types of roll paper. When using the printer for the first time, use the roll paper that is included in the package. Order extra rolls from your nearest YOKOGAWA dealer.

Part No.	B9316FX
Specifications	Thermalsensible paper, 10 m
Quantity	10 rolls

- **Handling Precautions of the Roll Paper**

The paper is a thermalsensible paper that changes color with the application of heat. Note the following points.

- **Storage Precautions**

The paper starts changing color at around 70°C. It is affected by heat, humidity, light, and chemicals regardless of whether the paper has been used or not.

- Store the paper rolls in a cool, dry, and dark place.
- After opening the package, use it quickly.
- If the paper is left in contact with plastic film containing plasticizers (such as a vinyl chloride film or Scotch tape) for an extended time, the paper will lose some of its ability to reproduce color. If you are going to store the paper in a folder, for example, use a folder made of paper stock or polypropylene.
- When using glue on the paper, do not use glue containing organic solvents such as alcohol or ether, as they will change the color of the paper.
- For prolonged storage, we suggest you copy the roll chart. Due to the characteristics of the thermalsensible paper, it may lose color over time.

- **Handling Precautions**

- Use only genuine paper rolls provided by YOKOGAWA.
- Touching the paper with sweaty hands can leave finger prints or blur the printing.
- Rubbing the surface with a hard object can cause the paper to change color due to the heat caused by friction.
- If chemicals, oil, or other liquids come in contact with the paper, the paper may change color or the printing may fade.

Note

- If you open the printer cover immediately after you cut the roll paper, repeat steps 5 to 7.
 - After loading the roll paper and closing the printer cover, feed the paper to check that the paper is being fed correctly. If the paper is not being fed evenly, repeat steps 1 to 7.
 - If you reverse the direction in which the roll paper is placed, the printer head does not make contact with the thermal-sensitive surface. If this happens, nothing may be printed, or the paper may not feed properly. Be sure to load the roll paper in the correct direction in the holder.
-

2.3 Printing Screen Images on the Built-in Printer

Procedure

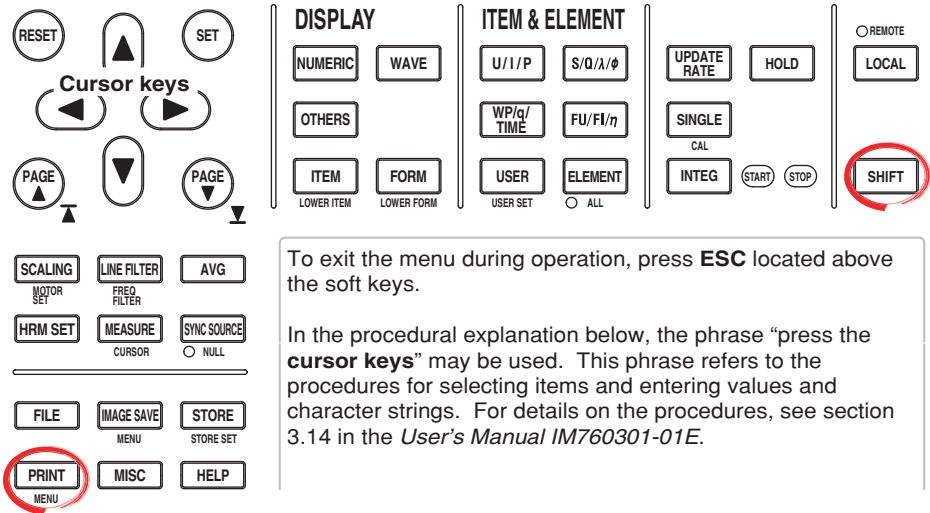

1. Press **SHIFT+PRINT (MENU)** to display the Print menu.
- **Selecting the Printer**
 2. Press the **Print to** soft key to display the Print to menu.
 3. Press the **Built-in** soft key.
 - **Selecting the Print Format**
 4. Press the **Print Format** soft key to display the Print Format menu.
 5. Press the **Hard Copy** soft key.

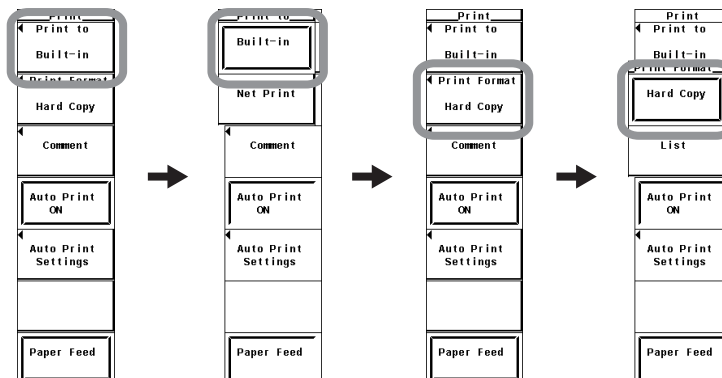

2.3 Printing Screen Images on the Built-in Printer

- **Setting Comments**

2. Press the **Comment** soft key. A keyboard appears.
3. Use the **keyboard** to enter the comment.

For keyboard operations, see section 3.14, "Entering Values and Strings" in the *User's Manual IM760301-01E*.

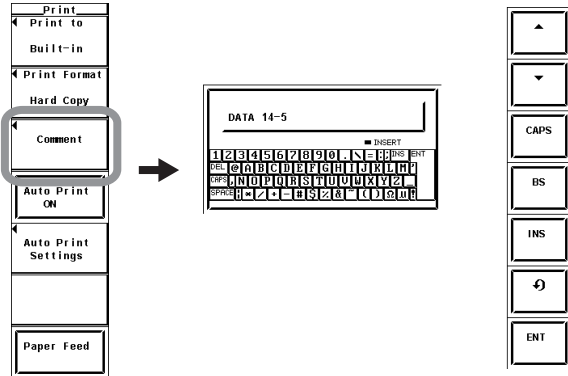

- **Executing the Print Operation**

Check that the roll paper is loaded properly, and that the printer unit is pushed into the correct position.

4. Switch to the screen you wish to print.
5. Press **PRINT** to print the screen image.

- **Aborting the Print Operation**

6. Press **PRINT** while the print operation is in progress to abort the operation.

Explanation

Screen images can be printed on the built-in printer (option).

Setting Comments

The comment that you entered is displayed at the bottom of the screen. The comment on the screen is also printed as a screen image.

Number and Types of Characters That Can Be Used

Item	Number of Characters	Characters That Can Be Used
Comment	0 to 20 * characters	Characters that are displayed on the keyboard and spaces

* More than 20 characters can be entered for the comment, but only the first 20 characters are displayed on the screen.

Note

If the roll paper runs out while printing, an error is displayed, and the screen image data being printed is discarded. If this happens, load a new roll paper, show the screen you wish to print again, and execute the print operation.

2.4 Printing Numeric Data Lists on the Built-in Printer

Procedure

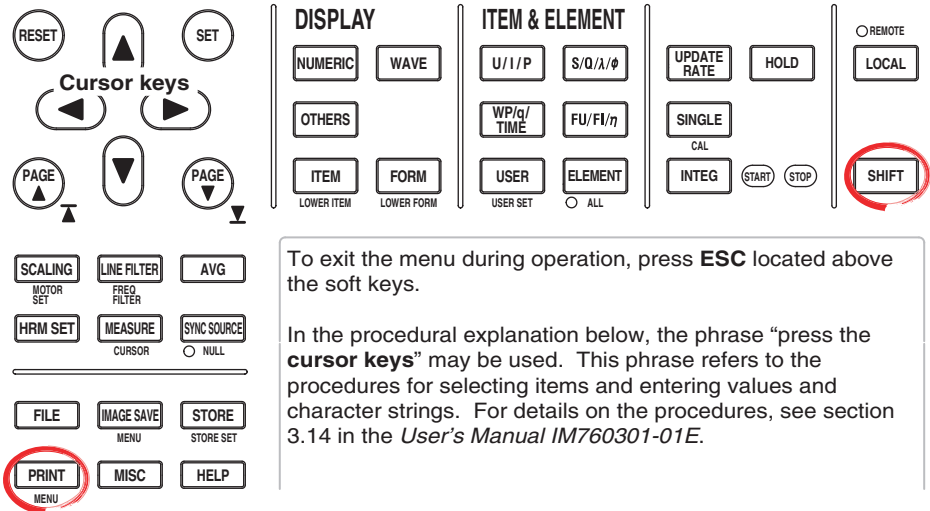

1. Press **SHIFT+PRINT (MENU)** to display the Print menu.
- **Selecting the Printer**
 2. Press the **Print to** soft key to display the Print to menu.
 3. Press the **Built-in** soft key.
 - **Selecting the Print Format**
 4. Press the **Print Format** soft key to display the Print Format menu.
 5. Press the **List** soft key.

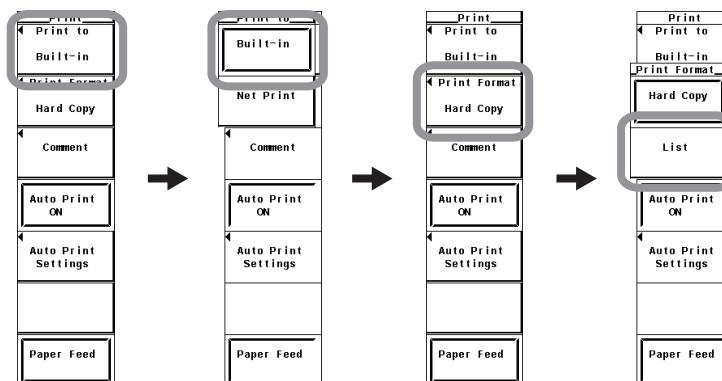

Note

The list cannot be printed in the following measurement modes. Only the screen image can be printed.

- Voltage fluctuation and flicker measurement mode
- Cycle-by-cycle measurement mode

2.4 Printing Numeric Data Lists on the Built-in Printer

- **Selecting the Numerical Data to Be Printed**

6. Press the **List Item** soft key to display the List Item dialog box.

- **Selecting the Items at Once**

7. Press the **cursor keys** to select All ON.

8. Press **SET**. The buttons to the left of all the elements and measurement functions are highlighted indicating that all items will be printed.

- **Deselecting All the Items at Once**

7. Press the **cursor keys** to select All OFF.

8. Press **SET**. The highlighting of the buttons to the left of all the elements and measurement functions are cleared indicating that all items will not be printed.

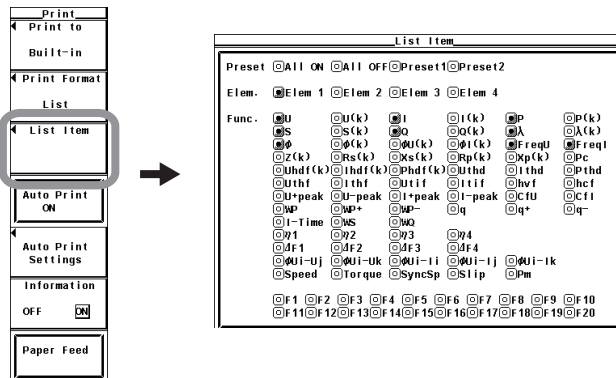

- **Selecting Only the Items That Are Preset**

7. Press the **cursor keys** to select Preset1 or Preset2.

8. Press **SET**. The buttons to the left of all the elements and measurement functions that are specified in Preset1 or Preset 2 are highlighted indicating that the items will be printed.

Items specified in Preset1

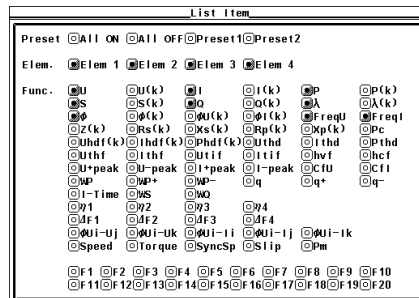

Items specified in Preset2

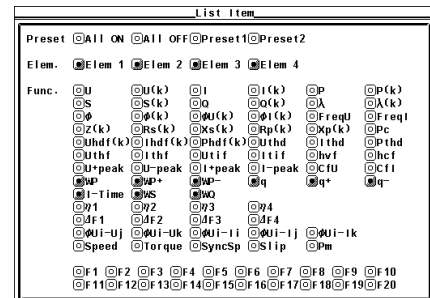

- **Setting the Items One at a Time**

7. Press the **cursor keys** to select the element or measurement function that you wish to specify.

8. Press **SET**. When the button to the left of the selected element or measurement function is highlighted, the numerical data of the measurement function of the element will be printed. When the highlighting of the button is cleared, the numerical data of the measurement function of the element will not be printed.

9. Press **ESC** to close the List Item dialog box.

- **Printing or Not Printing (ON/OFF) the Header Information**

10. Press the **Information** soft key to select ON or OFF.

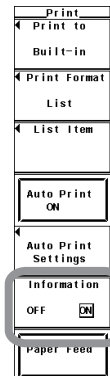

- **Executing the Print Operation**

11. Press **PRINT** to print the numeric data list.

- **Aborting the Print Operation**

12. Press **PRINT** while the print operation is in progress to abort the operation.

Explanation

- **Header Information**

The following items are available as header information.

- Measurement mode (Normal)*1
- Date/Time*1
- Measurement range of each element*2
- PLL source*2

Turning ON/OFF Header Information Printing

- ON: Prints the header information.
- OFF: Does not print the header information.

*1 Even if Information is set to OFF, the measurement mode and date/time are always printed.

*2 Only installed elements are applicable for the selection.

- **Selecting the Numeric Data**

- Only installed elements and wiring units are applicable for the selection.
- There are limitations on the numeric data that can be measured and printed in measurement modes*3 other than normal measurement mode. For details on the numeric data limitations, see appendix 11 in the *User's Manual IM760301-01E*. [----] (no data) is printed in places where there is no numeric data.
- The harmonic order range is DC (0th) to the Max Order specified in section 7.5.

*3 Can be set on models with the advanced computation (/G6) option. Wide bandwidth harmonic measurement mode, IEC harmonic measurement mode, waveform computation mode, and FFT mode are available.

- **Print Format of the Numeric Data List**

- The selected numeric data items are printed.
- For harmonic order data, the elements and measurement functions are printed horizontally, and the order list is printed vertically.

2.5 Auto Print

Procedure

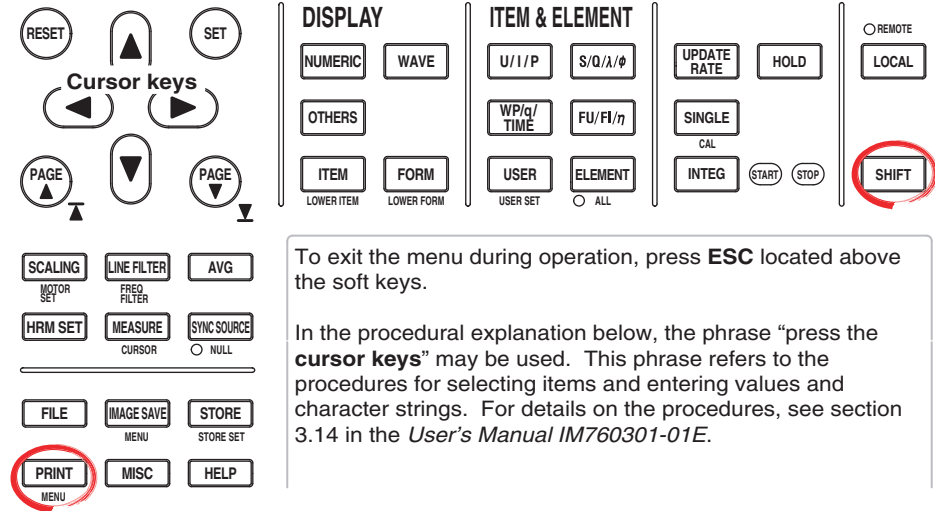

1. Press **SHIFT+PRINT (MENU)** to display the Print menu.
- **Setting the Print Destination, Output Format, Etc.**
 2. Set the print destination to the built-in printer, and set the output format according to the procedures given in sections 2.3 and 2.4.
 - **Selecting the Synchronization Mode**
 3. Press the **Auto Print Setting** soft key to display the Auto Print Setting menu.
 4. Press the **cursor keys** to select Synchronize.
 5. Press **SET** to select Timer or Integrate.

If you select Timer, proceed to step 6 in “Print Timer Synchronized Auto Print” on the next page.

If you selected Integrate, proceed to step 6 in “Integration Synchronized Auto Print” on page 2-14.

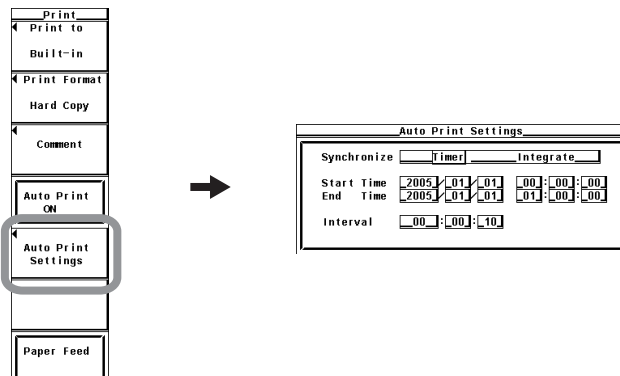

Print Timer Synchronized Auto Print

- **Setting the Reservation Time**

5. Press the **cursor keys** to select one of the reservation year, month, date, hour, minute, and second boxes for specifying when the printing will start (Start Time).
6. Press **SET** to display the entry box.
7. Press the **cursor keys** to set the year, month, date, hour, minute, or second that you selected in step 5.
8. Press **SET** or **ESC** to close the box.
9. Repeat steps 5 to 8 to set the year, month, date, hour, minute, and second.
10. Press the **cursor keys** to select one of the reservation year, month, date, hour, minute, and second boxes for specifying when the printing will end (End Time).
11. Repeat steps 6 to 8 to set the year, month, date, hour, minute, and second.

- **Setting the Print Interval**

12. Press the **cursor keys** to select the hour, minute, or second box of the print interval.
13. Press **SET** to display the entry box.
14. Press the **cursor keys** to set the hour, minute, or second that you selected in step 12.
15. Press **SET** or **ESC** to close the box.
16. Repeat steps 12 to 15 to set the hour, minute, and second.

- **Executing the Auto Print**

Check that the roll paper is loaded properly, and that the printer unit is pushed into the correct position.

17. Press the **Auto Print ON** soft key. If the reservation time for starting the printing is later than the time when Auto Print ON is pressed, the PRINT key blinks, and the WT3000 enters the Ready state. When the reservation time for starting the printing is reached, the PRINT key illuminates (stops blinking), and the auto print is started. If the reservation time for starting the printing is earlier than the time when Auto Print ON is pressed, the PRINT key illuminates, and auto print starts.

- **Aborting the Print Operation**

18. Press **PRINT** while the print operation is in progress to abort the operation.

- **Terminating the Auto Print**

- **Stopping the Auto Print**

8. Press the **Auto Print OFF** soft key while auto print is in progress to stop the auto print. The PRINT key turns OFF.

- **Automatically Stopping the Auto Print**

8. When the reservation time for stopping the auto print is reached, the auto print stops. The PRINT key turns OFF.

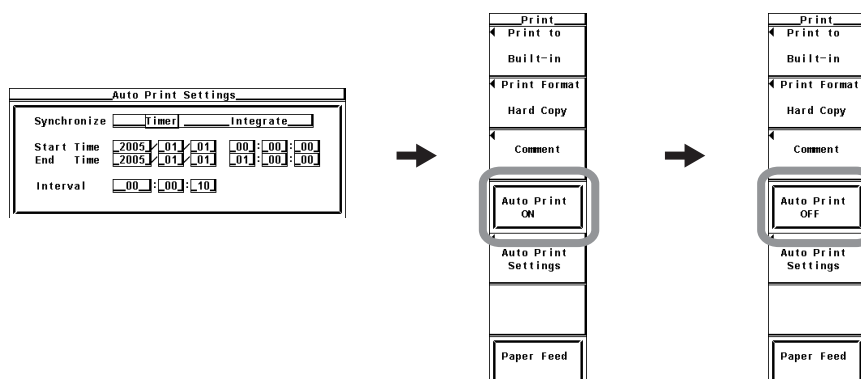

Integration Synchronized Auto Print

- **Setting the Print Interval**

5. Press the **cursor keys** to select the hour, minute, or second box of the print interval.
6. Press **SET** to display the entry box.
7. Press the **cursor keys** to set the hour, minute, or second that you selected in step 12.
8. Press **SET** or **ESC** to close the box.
9. Repeat steps 5 to 8 to set the hour, minute, and second.

- **Executing the Auto Print**

Check that the roll paper is loaded properly, and that the printer unit is pushed into the correct position.

10. Press the **Auto Print ON** soft key. If Auto Print is turned ON while integration is not started, the PRINT key blinks, and the WT3000 enters the Ready state. When integration starts, the PRINT key illuminates (stops blinking), and the auto print is started. If Auto Print is turned ON while integration is in progress, the PRINT key illuminates, and the auto print starts

- **Aborting the Print Operation**

11. Press **PRINT** while the print operation is in progress to abort the operation.

- **Terminating the Auto Print**

- **Stopping the Auto Print**

8. Press the **Auto Print OFF** soft key while auto print is in progress to stop the auto print. The PRINT key turns OFF.

- **Automatically Stopping the Auto Print**

8. When the integration stops, auto print also stops. The PRINT key blinks.
9. Press the **Auto Print OFF** soft key to turn the PRINT key OFF.

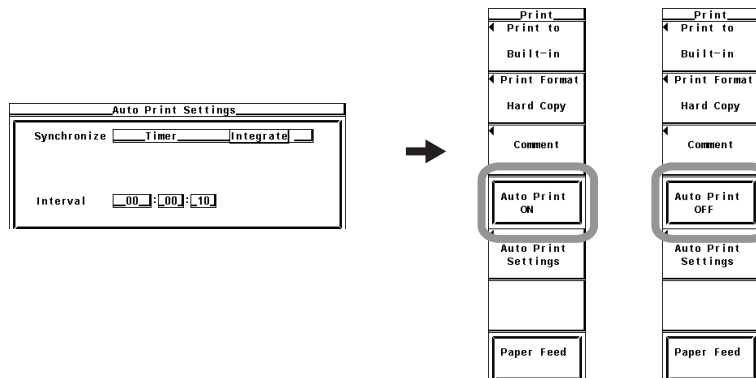

Explanation

When auto print is used, screen images and numeric data lists can be printed automatically on the built-in printer at the specified print interval.

- **Limitations on the Auto Print Function by Measurement Modes**

There are limitations on the setting and execution of auto print in measurement modes other than normal measurement mode.

- The synchronization mode (Synchronize) cannot be set to integration synchronization mode (Integrate), because the integration function is not available in the following measurement modes.
 - Wide bandwidth harmonic measurement mode
 - Waveform computation mode
 - FFT mode
- The auto print function cannot be used in the following measurement modes.
 - IEC harmonic measurement mode
 - Voltage fluctuation and flicker measurement mode
 - Cycle-by-cycle measurement mode

- **Setting the Print Destination, Output Format, Etc.**

To use the auto print function, you must set the print destination to the built-in printer and set the output format (screen image/numeric data) and other settings. For the procedure, see section 2.3 or 2.4.

Note

- If numerous measurement functions are set as print items, printing may take a long time. Set the print interval longer than the time needed for printing.
- If you operate the keys or perform communications at the time of printing, the print start time may be delayed, or the printing may take a long time.

- **Selecting the Synchronization Mode of the Auto Print**

You can select the method used to start/stop the auto print from the following:

- **Timer:** Starts/Stops printing in sync with preset reservation times (start and stop times) (print timer synchronized auto print).
- **Integrate:** Starts/Stops printing in sync with integration start/stop (integration synchronized auto print).

- **Setting the Reservation Time**

Set the time to start/stop the auto print in year:month:day, hour:minute:second. The start and stop times can be specified only when the synchronization mode is set to Timer. Make sure the reservation time for stopping the auto print is after the reservation time for starting the auto print.

The selectable range of the values is as follows:

- Year: 4-digit year
- Hour:Minute:Second: 00:00:00 to 23:59:59

Note

- The reservation time allows up to 31 days to be specified for February. If an invalid time is specified, an error message is displayed at the time of execution of the auto print. Reset the reservation time in this case.
- Leap years are recognized at the time of execution of the auto print.

- **Setting the Print Interval**

Set the time interval for carrying out auto print in hour:minute:second. The selectable range varies depending on the data update rate as follows:

- When the data update rate is less than 10 s: 00:00:10 to 99:59:59
- When the data update rate is greater than or equal to 10 s: 00:01:00 to 99:59:59

In integration synchronized auto print, the print interval is rounded up to an integer multiple of the data update rate. For example if the data update rate is set to 5 s and the print interval is set to 21 s, the print interval is set to 25 s.

Note

- The print interval can be set to a value smaller than the minimum value indicated above. If an invalid time is specified, an error message is displayed at the time of execution of the auto print. Reset the reservation time in this case.
-

- **Limitations When Auto Print is in Progress**

- To use the auto print function, you must set the print destination to the built-in printer and set the output format and other settings. For the procedure, see section 2.3 or 2.4.
- The settings of the following functions cannot be changed while auto print is in progress.
The synchronization mode, reservation time and interval of auto print; printer output items; wiring system; crest factor; synchronization source; data update rate; setting or execution of store/recall; and loading of setup parameter files
- If the following operation is carried out when auto print is to be executed, the auto print is not executed.
 - Formatting the storage medium
 - Accessing the storage medium such as saving data or settings
 - Carrying out an FTP server command
 - Printing manually or through communication commands
- If the print format is set to Hard Copy and an error or warning message is shown on the screen when the auto print is executed, the screen image including the message is printed. The message is automatically cleared after the printing. This prevents the screen images from being covered by the message on subsequent auto prints.

• **Print Timing of the Print Timer Synchronized Auto Print**

- When the start time is before turning Auto Print ON

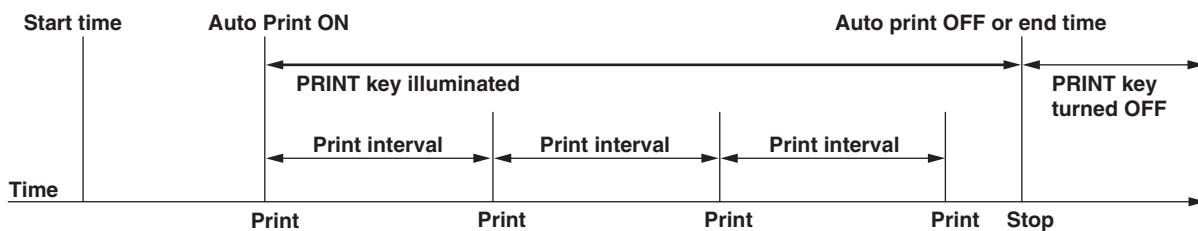

- When the start time is after turning Auto Print ON

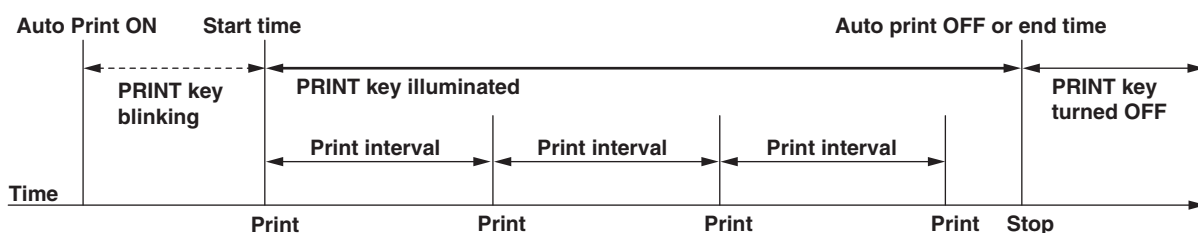

• **Print Timing of the Integration Synchronized Auto Print**

Auto print is executed based on the integration start time.

- When integration start is before turning Auto Print ON

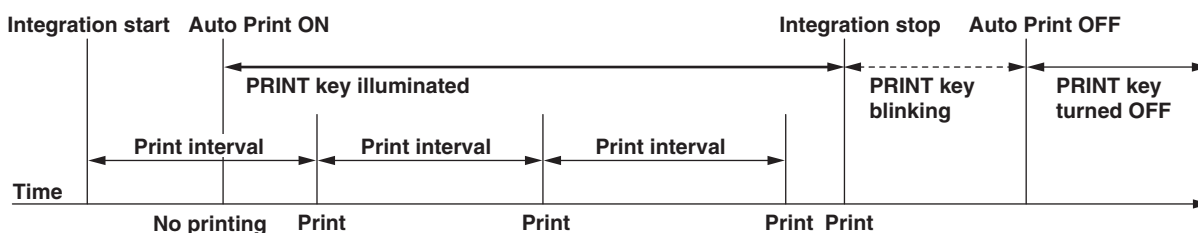

- When integration start is after turning Auto Print ON

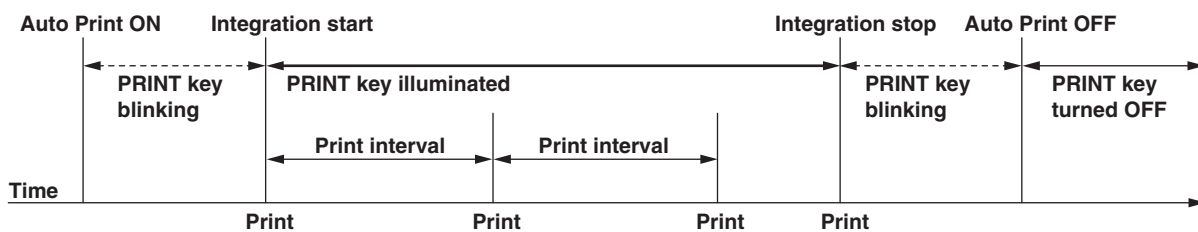

- Integration time and print interval during repetitive integration mode or real-time repetitive integration mode
When the integration timer expires, auto print is repeated based on that time.

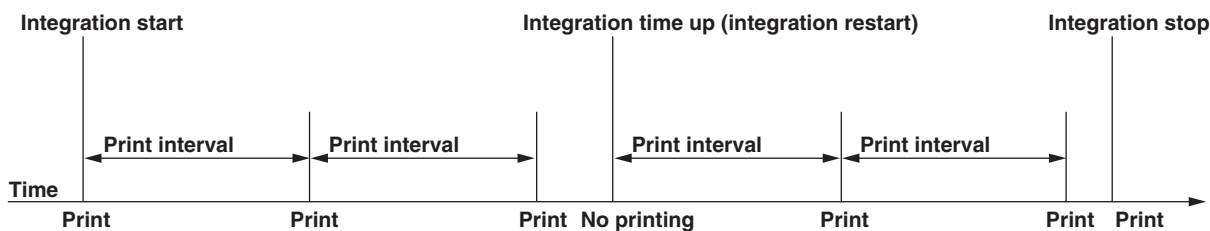

2.6 Built-in Printer Specifications

Item	Specifications
Print system	Thermal line dot system
Dot density	8 dots/mm
Paper width	112 mm
Printing width	104 mm
Auto print	Set the print interval to automatically print the measured values. Set the start and end times.

3.1 Part Names and Functions of D/A Output

Front Panel

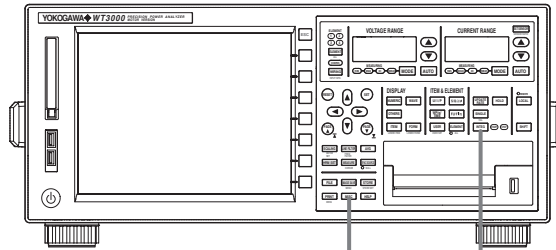

INTEG
Sets the rated time of integrated D/A output.

MISC
Sets the items necessary for D/A output.

Rear Panel

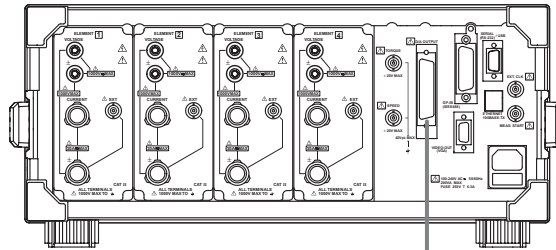

D/A output and remote control (option)
 D/A output: Outputs numeric data that has been converted to analog DC voltage.
 Remote control: Controls the WT3000 using an external signal between 0 to 5 V.

Pin Arrangement and Signal Assignment of the D/A Output Connector

The pin arrangement and assignments of the connector are as follows:

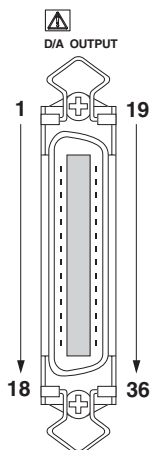

Pin No.	Signal Name	Pin No.	Signal Name
1	D/A CH1	19	D/A CH2
2	D/A CH3	20	D/A CH4
3	D/A CH5	21	D/A CH6
4	D/A CH7	22	D/A CH8
5	D/A CH9	23	D/A CH10
6	D/A CH11	24	D/A CH12
7	D/A CH13	25	D/A CH14
8	D/A CH15	26	D/A CH16
9	D/A CH17	27	D/A CH18
10	D/A CH19	28	D/A CH20
11	D/A COM	29	D/A COM
12	D/A COM	30	D/A COM
13	D/A COM	31	D/A COM
14	EXT PRINT	32	EXT RESET
15	EXT STOP	33	EXT START
16	EXT SINGLE	34	EXT HOLD
17	INTEG BUSY	35	EXT COM
18	EXT COM	36	EXT COM

Note

D/A COM and EXT COM are connected internally.

3.1 Part Names and Functions of D/A Output

Functional Description

- **D/A Output**

The numeric data measured on the WT3000 can be output as analog signals to other instruments. The analog signal is DC voltage of ± 5 V FS. The numeric data of up to 20 items can be output.

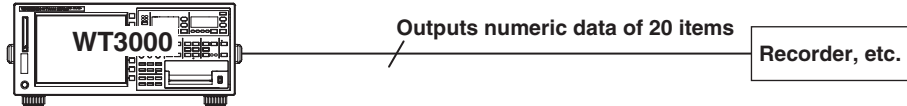

- **Remote Control**

Hold, single measurement, integration start/stop/reset, and print output can be controlled externally.

3.2 Setting the D/A Output

Procedure

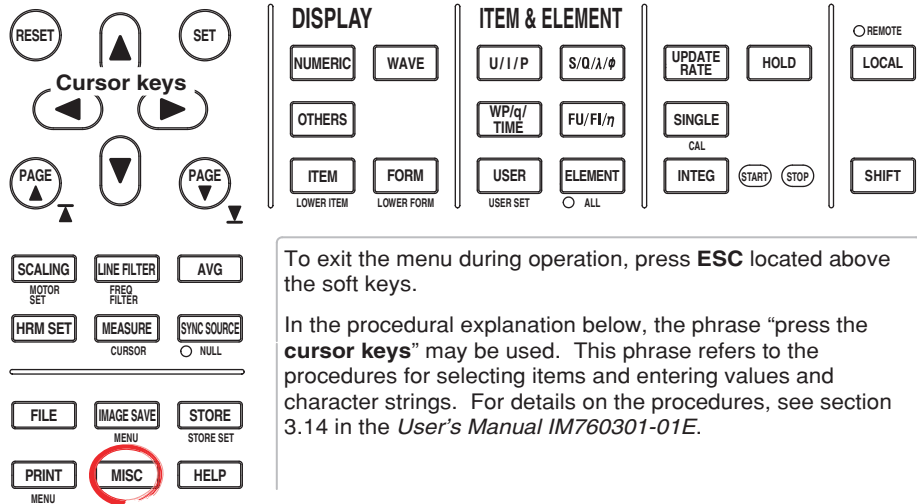

1. Press **MISC** to display the Misc menu.
2. Press the **Next 1/2** soft key to display the Next 2/2 menu.
3. Press the **D/A Output Items** soft key to display the D/A Output menu.

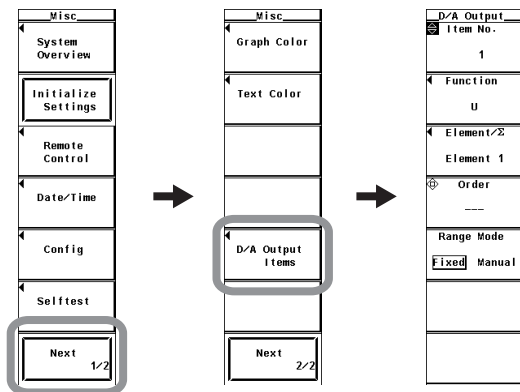

Setting the D/A Output Items

- **Selecting the Target Channel**
 4. Press the **cursor keys** to select a value between 1 and 20.
- **Selecting the Measurement Function**
 5. Press the **Function** soft key. The measurement function selection box appears.
 6. Press the **cursor keys** to select any of the measurement functions starting with None.
 7. Press **SET** to confirm.

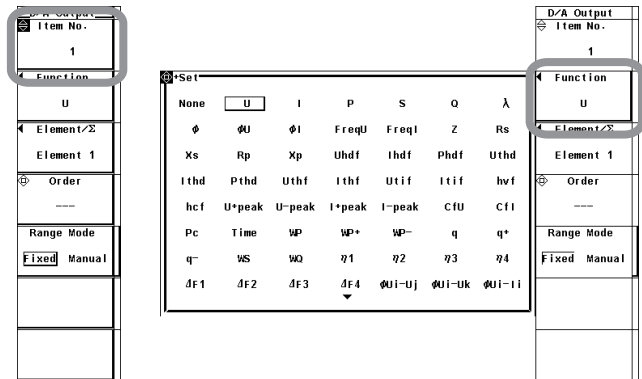

- **Selecting the Element/Wiring Unit**
 8. Press the **Element/Σ** soft key. The element/wiring unit selection box appears.
 9. Press the **cursor keys** to select any of the elements/wiring units starting with Element1.
 10. Press **SET** to confirm.
- **Selecting the Harmonic Order (Applicable Only on Models with the Advanced Computation Option or Harmonic Measurement Option)**

This is displayed only on models with the harmonic measurement option.

 11. Press **Order** soft key.
 12. Press the cursor keys to select the order.
 - When the measurement mode is normal measurement, waveform computation,* or FFT,* select --- (normal measured value), or an order between 0 and the maximum measured order.
 - When the measurement mode is wide bandwidth harmonic measurement,* select Total (total value), or an order between 0 and the maximum measured order.

* Can be set on models with the advanced computation (/G6) option.

To output measurement functions related to integration through the D/A output, proceed to step 13.

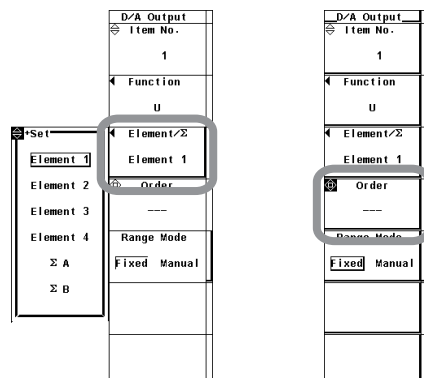

Setting the Rated Time of Integrated D/A Output

13. Press **INTEG** to display the Integ menu.
14. Press the **Integ Set** soft key to display the Integ Set menu.
15. Press the **D/A Output Rated Time** soft key to display the D/A Rated Time dialog box.
16. Press the **cursor keys** to select the hour, minute, or second box.
17. Press **SET**. An entry box appears.
18. Press the **cursor keys** to set the hour, minute, or second that you selected in step 16.
19. Press **SET** or **ESC** to close the box.
20. Repeat steps 16 to 19 to set the hour, minute, and second.

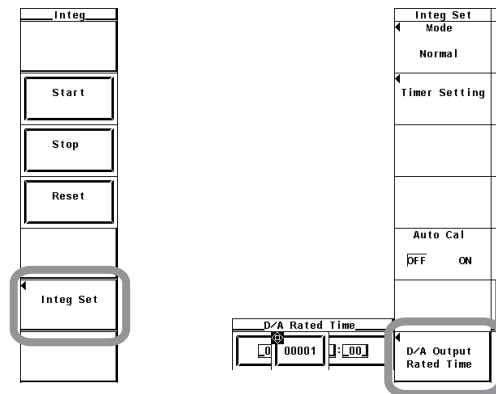

Checking the D/A Output Items

1. Press **SHIFT+WIRING**(INPUT INFO.). Power Element Settings appears.
2. Press **PAGE ▼** to show DA Output Settings (a list of D/A output settings). The relation table of D/A output channels and measurement functions is displayed.

D/A Output Settings

Ch.	Item	Rate
Ch. 1	Urms1	Fixed
Ch. 2	Irms1	Fixed
Ch. 3	P1	Fixed
Ch. 4	S1	Fixed
Ch. 5	Q1	Fixed
Ch. 6	λ1	Fixed
Ch. 7	φ1	Fixed
Ch. 8	IU1	Fixed
Ch. 9	I11	Fixed
Ch. 10	----	Fixed
Ch. 11	----	Fixed
Ch. 12	----	Fixed
Ch. 13	----	Fixed
Ch. 14	----	Fixed
Ch. 15	----	Fixed
Ch. 16	----	Fixed
Ch. 17	----	Fixed
Ch. 18	----	Fixed
Ch. 19	----	Fixed
Ch. 20	----	Fixed

Explanation

The numeric data can be output using ± 5 -V FS DC voltage from the D/A output connector on the rear panel. Up to 20 items (channels) can be specified.



CAUTION

Do not short the D/A output terminal or apply external voltage to it. If you do, the instrument may malfunction.

Limitations on the D/A Output Function by Measurement Modes

There are limitations on the setting and execution of the D/A output in measurement modes other than normal measurement mode.

- There is a limitation on the numeric data that can be measured and delivered through D/A output in the measurement modes listed below. For details on the numeric data limitations, see appendix 11 in the *User's Manual IM760301-01E*. The WT3000 outputs 0 V where no numeric data exists.
 - Wide bandwidth harmonic measurement mode
 - Waveform computation mode
 - FFT mode
- The D/A output function cannot be used in the following measurement modes. The WT3000 outputs 0 V on all channels.
 - IEC harmonic measurement mode
 - Voltage fluctuation and flicker measurement mode
 - Cycle-by-cycle measurement mode

D/A Output Item

- **Selecting the Measurement Function**
 - The types of measurement functions that can be selected are the items that are indicated in “Types of Measurement Functions during Normal Measurement” of section 2.2, “User-Defined Function” and “Corrected Power” of section 2.5, “Measurement Functions of Integration” of section 2.6 in the *User's Manual IM760301-01E*, as well as “Motor Evaluation Function (Motor Version)” of chapter 1, “Delta Computation (Option)” of chapter 6, and “Harmonic Measurement (Option)” of chapter 7 in this manual.
 - You can also select not to output the measurement functions (None). For channels that are set to None, 0 V is output since no corresponding data exists.
 - If the range mode (see section 3.3) is set to fixed, the D/A output of a channel whose measurement function is set to Z, Rs, Xs, Rp, Xp, or F1 to F20 is fixed to 0 V. It is output when the range mode is set to manual.
- **Selecting the Element/Wiring Unit**
 - You can select the element/wiring unit from the choices below. The selectable items vary depending on the installed elements.
Element1, Element2, Element3, Element4, ΣA , and ΣB
 - If there are no elements that are assigned to the selected wiring unit, there is no numeric data. Thus, 0 V is output in this case. For example, if elements are assigned to ΣA and no elements are assigned to ΣB , then 0 V is output for the measurement function of ΣB .

- **Changing the Harmonic Order of the Measurement Function of Harmonic Measurement**

When the measurement mode is set to normal measurement, waveform computation, or FFT, the measured order can be set to normal measured value (---) or from dc (0th order) up to 100th order.

When the measurement mode is set to wide bandwidth harmonic measurement mode, the measured order can be set to total value or from dc (0th order) up to 100th order.

Note

- For the meanings of the measurement function symbols that are output, see section 2.2, "Measurement Function and Measurement Period", 2.5, "Computation," 2.6, "Integration", and appendix 1, "Symbols and Determination of Measurement Functions" in the *User's Manual IM760301-01E* as well as chapter 1, "Motor Evaluation Function," chapter 6, "Delta Computation", and chapter 7, "Harmonic Measurement" in this manual.
- For details on the wiring units expressed as ΣA and ΣB , see section 4.1, "Selecting the Wiring System" in the *User's Manual IM760301-01E*.
- 0 V is output in places where the measurement function is not selected or there are no numeric data.
- The range of the order of the numeric data determined by the harmonic measurement is from the minimum measured order specified in section 7.5 up to the upper limit of the measured order that is automatically determined by the PLL source frequency (see section 7.9). There is no numeric data for orders of numeric data of D/A output items outside this range even if you specify such orders. For harmonic orders less than the minimum measured order specified in section 7.5 (for example, 0th order when Min Order is set to 1st order) and those greater than the maximum measured order, the output is 0 V.
- If scaling factors such as VT ratio, CT ratio, and power coefficient are specified on the voltage, current, and power, and the scaling is ON, 100% (5 V) is output when the scaled value is equal to the scaled rated value (measurement range \times scaling factor).
- For Σ functions, 100% (5 V) is output when the input is equal to the total value that is obtained when the rated value is input to each corresponding element. If different scaling factors are placed on each element, 100% (5 V) is output when the scaled value is equal to the scaled rated value (measurement range \times scaling factor).

3.2 Setting the D/A Output

Rated Time of Integrated D/A Output

In the case of integrated values, the integrated value that is obtained while continuously applying a rated value (same value as the measurement range) for the specified time is taken to be 100%. The D/A output at that point is 5 V. The D/A output from the integrated value of 0 (0 V) to the integrated value of 100% (5 V) is assumed to change linearly with time. The D/A output value is determined by the level of the actual input with respect to this assumed line (see the figure on the next page).

Setting the Rated Time of Integrated D/A Output

- Set the time in units of hour : minute : second in the following range.
00000:00:00 to 10000:00:00
- This setting is valid in the manual integration mode.
- For normal integration and repetitive integration modes (includes real-time), the time specified for the timer is the rated time of integrated D/A output.

Note

When the rated time of integrated D/A output is 00000:00:00, the D/A output of the integrated value is fixed to 0 V.

Relationship between the Output Items and D/A Output Voltages

- Frequency (Simplified Figure Below)

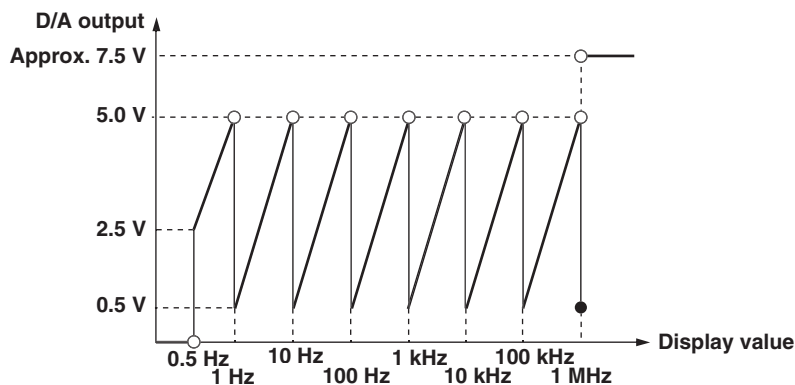

- Integration Value

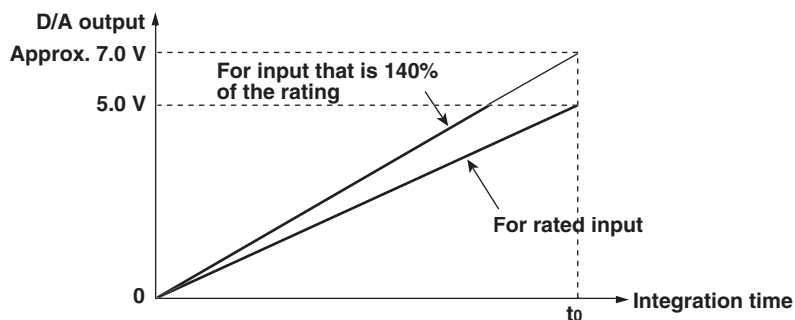

t_0 : Integrated D/A output rated time when in manual integration mode
Time specified for the timer when in standard integration or repetitive (continuous) integration mode

- Other Items

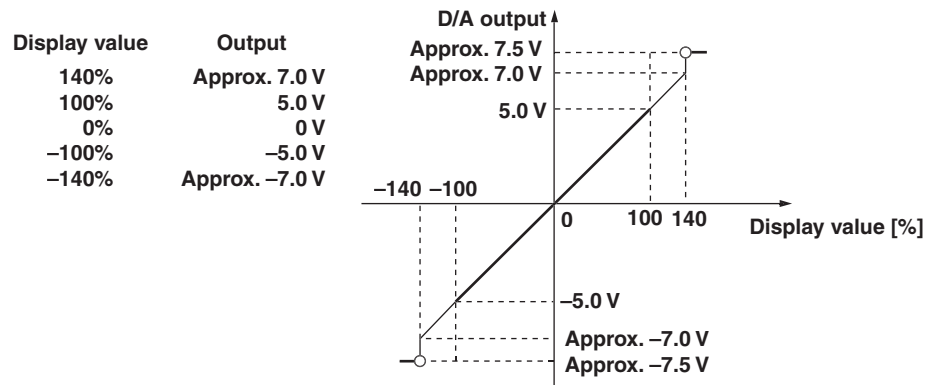

- λ and ϕ are not output outside ± 5 V. If the display format is ϕ is 360 degrees (360° format), ϕ is output in the range of 0 V to +5 V. If the display format is ϕ is 180 Lead/lag (180° lag to 180° lead), ϕ is output in the range of -5 V to +5 V. When an error occurs, approximately 7.5 V is output. For U-pk and I-pk only, approximately -7.5 V is output when an error occurs.
 - For η_1 to η_4 , Uhdf, lhdf, Phdf, Uthd, lthd, Pthd, Uthf, lthf, hvf, hcf, and Slip*, +5 V is output when the measured value is equal to 100%.
 - For Utif and Itif, +5 V is output when the measured value is equal to 100.
 - For Torque*, +5 V is output when the torque signal is an analog signal and the measured value is equal to a value (rated value) defined by “input range” \times “torque scaling factor.” For example, with an input range of 10 V, if the scaling factor is set to 1 N-m torque per 1 V input voltage, +5 V is output when torque is 10 N-m.
 - For Speed*, +5 V is output when the rotating signal is an analog signal and the measured value is equal to a value (rated value) defined by “input range” \times “torque scaling factor.” For example, with an input range of 10 V, if the scaling factor is set to 100 rpm rotating speed per 1 V input voltage, +5 V is output when the rotating speed is 1000 rpms.
 - For Speed*, -5 V is output when the rotating signal is a pulse signal and the rotating speed falls to the lower limit $\times (-1)$ of Pulse Range under Speed in section 1.6, and +5 V is output when the rotating speed reaches the upper limit.
 - For Torque*, -5 V is output when the torque signal is a pulse signal and the torque falls to the lower limit $\times (-1)$ of Pulse Range under Torque in section 1.6, and +5 V is output when the torque reaches the upper limit.
 - For SyncSp*, +5 V is output when measured value is equal to the rated value of speed.
 - For Pm*, +5 V is output when the measured value is equal to a motor output determined by the torque and the rated value of the rotating speed.
- * Applicable only to products with the motor evaluation function (motor version).

3.3 Setting the D/A Zoom

Procedure

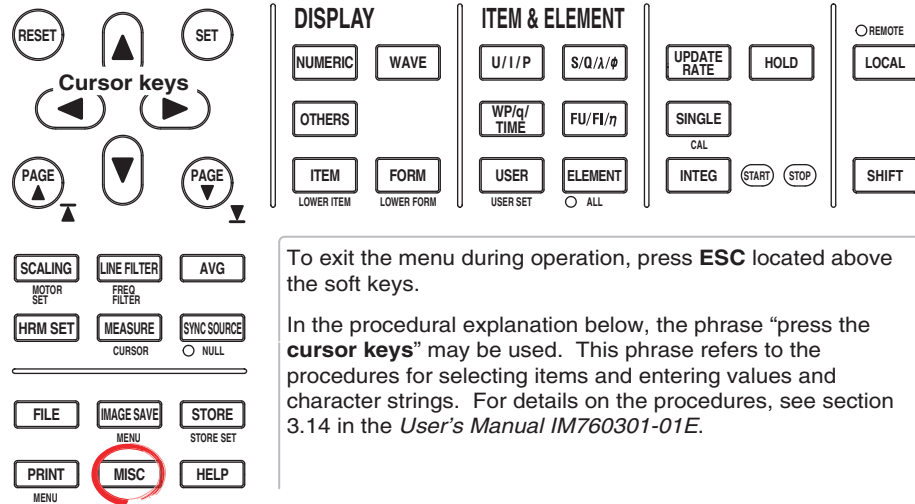

1. Press **MISC** to display the Misc menu.
 2. Press the **Next 1/2** soft key to display the Next 2/2 menu.
 3. Press the **D/A Output Items** soft key to display the D/A Output menu.
- **Selecting the Target Channel**
 4. Press the **cursor keys** to select a value between 1 and 20.
 - **Selecting Whether to D/A Zoom (Manual Range Mode or Fixed Range Mode)**
 5. Press the **Range Mode** soft key to select Manual or Fixed. If Manual is selected, proceed to step 6.
 - **Setting the Maximum Value of the D/A Output Range for Manual Range Mode**
 6. Press the **Rated Max** soft key.
 7. Press the **cursor keys** to set the maximum value.
 - **Setting the Minimum Value of the D/A Output Range for Manual Range Mode**
 8. Press the **Rated Min** soft key.
 9. Press the **cursor keys** to set the minimum value.

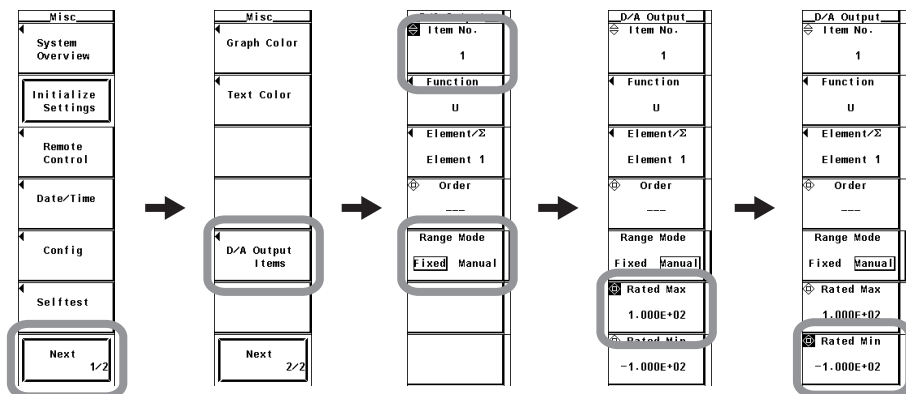

Explanation

- **D/A Zoom**

The D/A output can be magnified or reduced for each channel in manual range mode by setting the D/A output range. For example, if a current varying in the range of 0.6 A to 0.8 A is measured at the 1-A range and the D/A output is set to fixed range mode, the D/A output voltage varies between 3.0 V and 4.0 V. If you wish to magnify this variation, you can use the D/A zoom function. In this example, set the D/A output to manual range mode and set the maximum and minimum values to 0.6 and 0.8, respectively. Then, the D/A output delivers -5 V and +5 V when the measured current is 0.6 A and 0.8 A, respectively.

- **Selecting the D/A Output Range Mode**

Select either mode from below.

- **Manual**

The displayed values of the measurement functions corresponding to the D/A output of -5 V and +5 V can be set arbitrarily.

- **Fixed**

Outputs +5 V when the rated value of each measurement function is applied. For details, see section 3.2.

- **Setting the Maximum and Minimum Values for Manual Range Mode**

The maximum and minimum values can be set in the range of $-9.999\text{E}+30$ to $9.999\text{E}+30$.

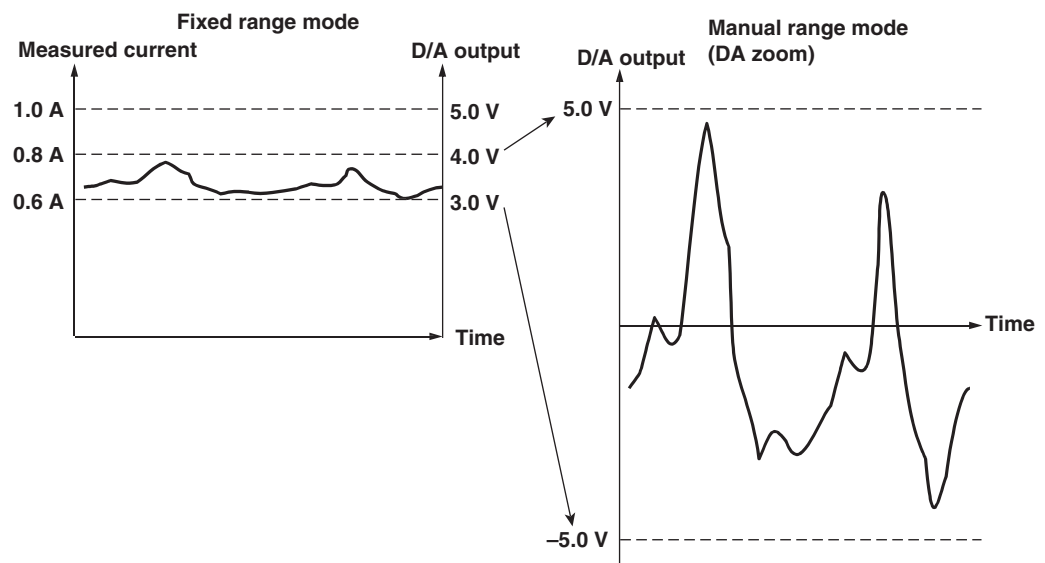

3.4 Remote Control

- **Remotely Controlling the Integration**

Enter the signals according to the timing chart below.

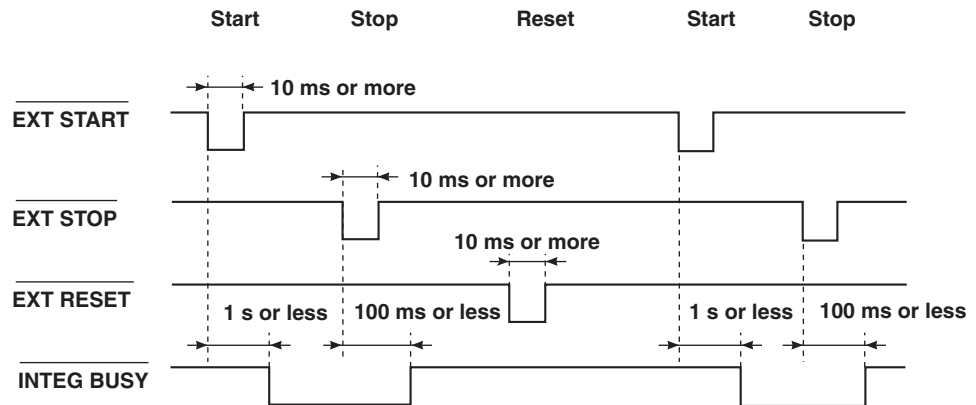

The $\overline{\text{INTEG BUSY}}$ output signal is set to low level while integration is in progress. Use this signal to monitor the integration operation.

- **Holding the Data Display (Same Function as the HOLD Key)**

Apply the $\overline{\text{EXT HOLD}}$ signal as shown in the figure below.

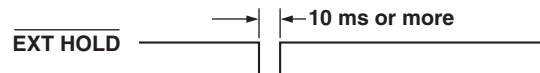

- **Updating the Display Data Being Held (Same Function as the SINGLE Key)**

Applying the $\overline{\text{EXT SINGLE}}$ signal while the display is held updates the display.

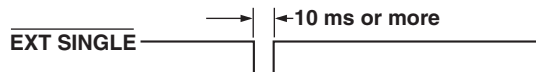

Note

If the period of the EXT SINGLE signal does not meet the conditions of the figure above, the signal may not be recognized by the WT3000.

- **Printing on the Built-in Printer (Option) (Same Function as the PRINT Key)**

Apply the $\overline{\text{EXT PRINT}}$ signal as shown in the figure below.

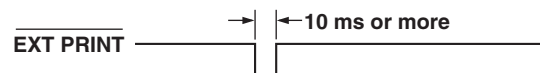

Explanation

Hold, single measurement, integration start/stop/reset, and print output can be controlled externally.



CAUTION

Do not apply voltage outside the range of 0 to 5 V to the remote control input pins. Also, do not short the output pins or apply external voltage to them. If you do, the instrument may malfunction.

- Remote Control Input/Output Circuit

Input circuit

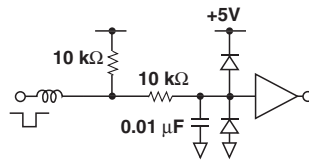

Low level: 0 to 1 V
High level: 4 to 5 V

Output circuit

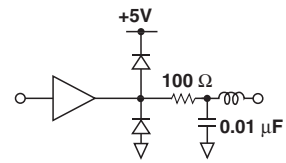

Low level: 0 to 1.5 V (8 mA)
High level: 2.8 to 5 V (-8 mA)

3.5 D/A Output and Remote Control Specifications

D/A Output

Item	Specifications
D/A conversion resolution	16 bits
Output voltage	±5 V FS (approx. ±7.5 V maximum) against each rated value.
Update interval	The same as the data update interval of the WT3000
Number of outputs	20 channels Output item for each channel specifiable.
Accuracy	±(accuracy of each measurement function + 0.1% of FS) FS = 5 V
Minimum load	100 kΩ
Temperature coefficient	±0.05% of FS/°C
Continuous maximum common mode voltage	±42 V _{peak} or less
Relationship between the output items and D/A output voltages	See section 3.2.

Remote Control

Item	Specifications
Signal	EXT START, EXT STOP, EXT RESET, INTEG BUSY, EXT HOLD, EXT SINGLE, and EXT PRINT
Input level	0 to 5 V

4.1 Names and Functions of the Parts of the RGB Video Signal (VGA) Output

Rear Panel

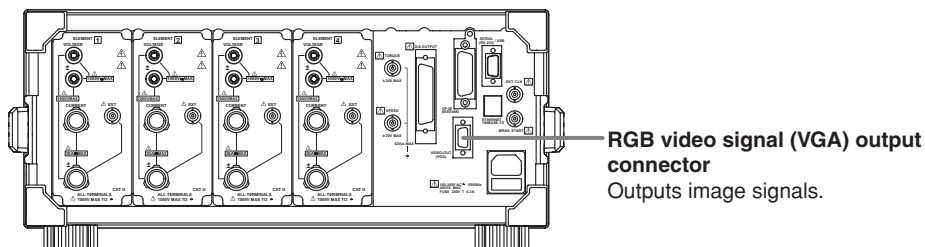

The WT3000 screen can be output to a monitor through the RGB video signal (VGA) output. Connectable monitors are VGA monitors or multi-sync monitors capable of displaying VGA.

CAUTION

- Connect the cable after turning OFF the WT3000 and the monitor.
- Do not short the RGB VIDEO OUT terminal or apply external voltage to it. If you do, the instrument may malfunction.

Pin Arrangement and Assignments of the Video Signal Output Connector

The pin arrangement and assignments of the connector are as follows:

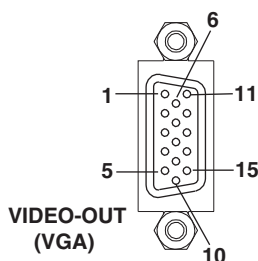

Pin No.	Signal Name	Specifications
1	Red	0.7 Vp-p
2	Green	0.7 Vp-p
3	Blue	0.7 Vp-p
4	—	
5	—	
6	GND	
7	GND	
8	GND	
9	—	
10	GND	
11	—	
12	—	
13	Horizontal sync signal	Approx. 31.5 kHz, TTL (negative logic)
14	Vertical sync signal	Approx. 60 Hz, TTL (negative logic)
15	—	

Connecting to the Monitor

1. Turn OFF the WT3000 and the monitor.
2. Connect the WT3000 and the monitor using an analog RGB cable.
3. The WT3000 screen appears on the monitor when both the WT3000 and the monitor are turned ON.

Note

- The RGB video signal is constantly output from the video signal output connector.
- The monitor screen may flicker if the WT3000 or another instrument is brought close to the monitor.
- The edge of the screen may drop out depending on the monitor type.

4.2 RGB Video Signal (VGA) Output Specifications

Item	Specifications
Connector type	D-sub 15 pin (receptacle)
Output type	VGA compatible

5.1 Connecting to the Network

When Connecting to a PC on the Network

1. Turn OFF the WT3000 power switch (see section 3.4 in the *User's Manual IM760301-01E*).
2. Connect one end of the UTP (or STP) cable to the ETHERNET 100BASE-TX terminal on the rear panel.
3. Connect the other end of the UTP (or STP) cable to a hub or router.
4. Turn ON the WT3000 power switch.

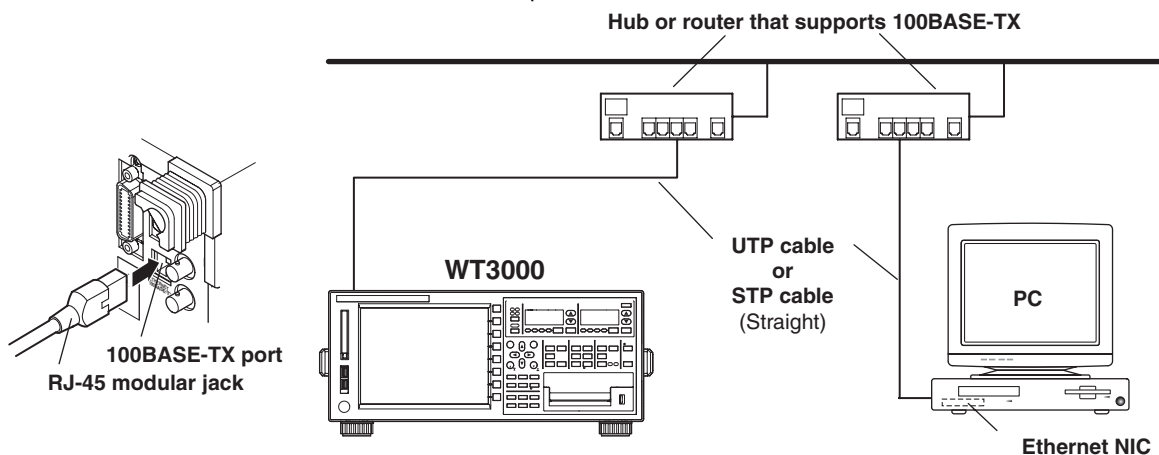

Connecting to the PC in a One-to-One Configuration

1. Turn OFF the WT3000 power switch (See section 3.4 in the *User's Manual IM760301-01E*).
2. Connect one end of the UTP (or STP) cable to the ETHERNET 100BASE-TX terminal on the rear panel.
3. Connect the other end of the UTP (or STP) cable to a hub or router.
4. Likewise, connect the PC to a hub or router.
5. Turn ON the WT3000 power switch (see section 3.4 in the *User's Manual IM760301-01E*).

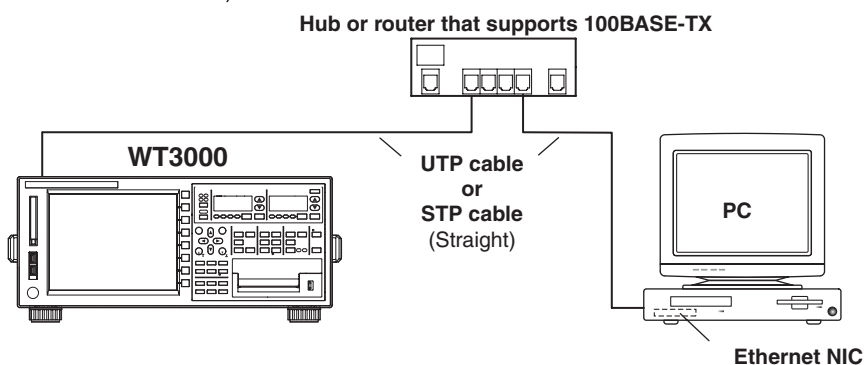

Note

- When connecting the WT3000 and a PC in a one-to-one configuration, use a 10BASE-T/100BASE-TX auto switching NIC or a 100BASE-TX NIC on the PC side.
- Use UTP (Unshielded Twisted-Pair) or STP (Shielded Twisted-Pair) cables of straight type and category 5 or better.
- Do not connect the WT3000 and a PC directly without going through a hub. Operations are not guaranteed for communications using direct connection.

5.2 Setting TCP/IP

Procedure

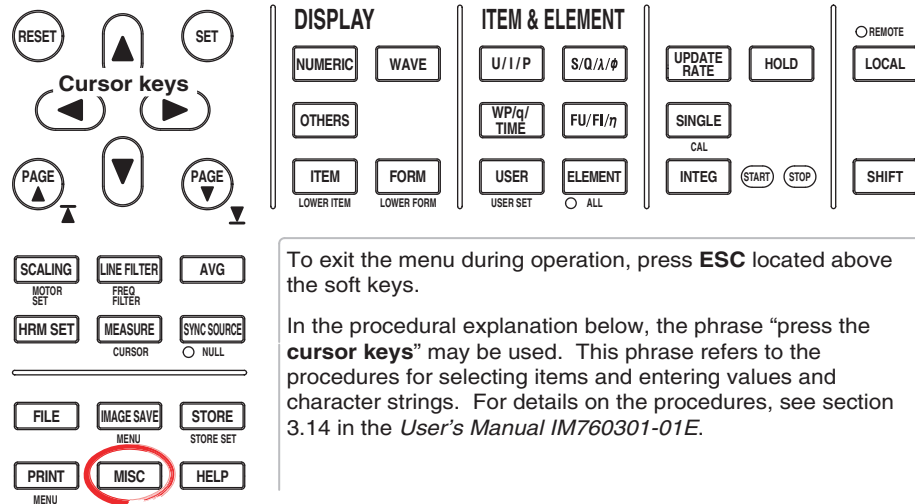

If you set the TCP/IP parameters for the first time or change the parameters, restart the WT3000 to apply the new settings.

1. Press **MISC** to display the Misc menu.
2. Press the **Next 1/2** soft key to display the Next 2/2 menu.
3. Press the **Network** soft key to display the Network menu.

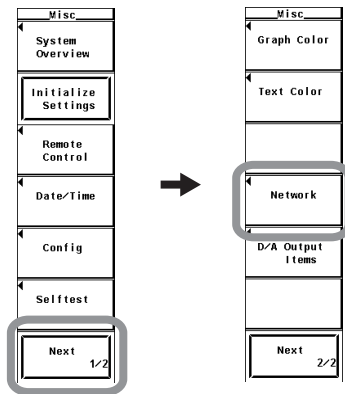

4. Press the **TCP/IP Setup** soft key to display the TCP/IP Setup dialog box.

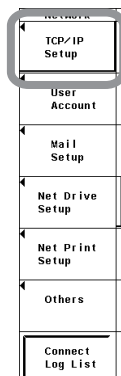

When Using Only DHCP

5. Press the **cursor keys** to select DHCP.
6. Press **SET** to select ON.
7. Press the **cursor keys** to select DNS.
8. Press **SET**. A DNS selection box appears.
9. Press the **cursor keys** to select OFF.

The screenshot shows the 'TCP/IP Setup' menu. At the top, it says 'TCP/IP Setup'. Below that, there are four rows of options:

- DHCP: OFF ON
- IP Address: 0 0 0 0
- Net Mask: 255 255 255 255
- Gate Way: 0 0 0 0
- DNS: OFF ON

When Using Only DNS

5. Press the **cursor keys** to select DHCP.
 6. Press **SET** to select OFF.
- **Entering the IP Address**
 7. Press the **cursor keys** to select IP Address.
 8. Press **SET**. An IP address entry box appears.
 9. Press the **cursor keys** to enter the IP address of the WT3000.
 10. Press **SET** or **ESC** to close the box.
 11. Enter all four octets of the **IP address**.

The screenshot shows the 'TCP/IP Setup' menu. The 'DHCP' option is now OFF ON. The 'IP Address' field is highlighted with a cursor, and a small box is open over it, showing the number '0'. The other fields remain the same as in the previous screenshot.

- **Entering the Subnet Mask**

Enter the subnet mask according to the system or network to which the WT3000 belongs. If the subnet mask is not required, proceed to “Entering the Default Gateway.”

 12. Press the **cursor keys** to select Net Mask.
 13. Enter all four octets of the subnet mask of the network to which the WT3000 belongs in the same fashion as the IP address.
- **Entering the Default Gateway**

Enter the default gateway according to the system or network to which the WT3000 belongs. If the default gateway is not required, proceed to “Turning ON the DNS.”

 14. Press the **cursor keys** to select Gate Way.
 15. Enter all four octets of the default gateway of the network to which the WT3000 belongs in the same fashion as the IP address.

- **Turning ON the DNS**

16. Press the **cursor keys** to select DNS.
17. Press **SET**. A DNS selection box appears.
18. Press the **cursor keys** to select ON.
19. Press **SET** to confirm the DNS ON setting.

- **Entering the Domain Name**

Enter the domain name of the system or network to which the WT3000 belongs.

20. Press the **cursor keys** to select Domain Name.
21. Press **SET**. A keyboard appears.
22. Use the **keyboard** to enter the domain name of the network to which the WT3000 belongs.

For keyboard operations, see section 3.14 in the *User's Manual IM760301-01E*.

- **Entering the Address of the Primary DNS Server**

23. Press the **cursor keys** to select DNS Server1.
24. Enter all four octets of the primary DNS server address in the same fashion as the IP address.

- **Entering the Address of the Secondary DNS Server**

Enter the information if the system or network to which the WT3000 belongs uses a secondary DNS server. If a secondary server is not used, proceed to "Entering the Primary Domain Suffix."

25. Press the **cursor keys** to select DNS Server2.
26. Enter all four octets of the secondary DNS server address in the same fashion as the IP address.

- **Entering the Primary Domain Suffix**

Enter the information if a domain suffix is required.

27. Press the **cursor keys** to select Domain Suffix1.
28. Enter the primary domain suffix in the same fashion as the domain name.

- **Entering the Secondary Domain Suffix**

Enter the information if a secondary domain suffix is present.

29. Press the **cursor keys** to select Domain Suffix2.
30. Enter the secondary domain suffix in the same fashion as the domain name.

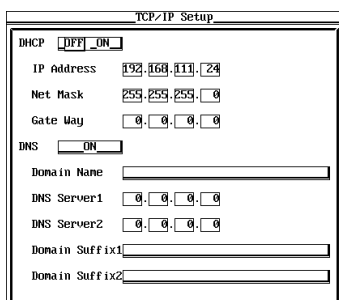

When Using Both DHCP and DNS

5. Press the **cursor keys** to select DHCP.
6. Press **SET** to select ON.
7. Press the **cursor keys** to select DNS.
8. Press **SET**. A DNS selection box appears.
9. Press the **cursor keys** to select ON or Auto.

If you selected ON, you must enter information according to “Entering the Domain Name” through “Entering the Secondary Domain Suffix” on the previous page.

If you selected Auto, the DHCP automatically sets the entry information from “Entering the Domain Name” to “Entering the Secondary Domain Suffix.”

Therefore, you do not have to enter the information.

The screenshot shows the 'TCP/IP Setup' menu. At the top, 'DHCP' is set to 'ON'. Below it, 'IP Address', 'Net Mask', and 'Gate Way' are all set to '0.0.0.0'. The 'DNS' menu is open, showing 'OFF', 'ON', and 'Auto' options. The 'Domain' and 'Domain Suffix2' fields are empty.

Restarting the WT3000

After you set the TCP/IP parameters for the first time or change the parameters, restart the WT3000 to apply the new settings.

Explanation

To use the Ethernet communication functions of the WT3000, the DHCP, IP address, IP address, subnet mask, default gateway, and DNS must be specified. Consult your system or network administrator when setting these parameters.

- **DHCP (Dynamic Host Configuration Protocol)**

DHCP is a protocol that allocates settings that are needed temporarily to PCs connecting to the network. If DHCP is turned ON when a DHCP server exists on the network, the parameters below are automatically assigned to PCs and other devices connected to the network.

IP address
Subnet mask
Default gateway
Broadcast
DNS

- To use DHCP, the network must have a DHCP server. Consult your network administrator to see if DHCP can be used.
- If DHCP is switched from OFF to ON, it may take several tens of seconds before the IP address can be retrieved.
- When DHCP is turned ON, different settings may be assigned each time the power is turned ON. When accessing the WT3000 from a PC using the FTP server function (see section 5.6), you must check the WT3000 TCP/IP settings such as the IP address each time the power is turned ON.

- **IP Address (Internet Protocol Address)**

You can set the IP address assigned to the WT3000. The default setting is 0.0.0.0.

- The IP address is an ID that is assigned to each device on an IP network such as the internet or an intranet.
- The address is a 32-bit value expressed using four octets (each 0 to 255), each separated by a period as in [192.168.111.24].
- Obtain an IP address from your network administrator.
- This parameter is automatically configured in environments using DHCP.

- **Subnet Mask**

You can set the mask value used when determining the subnet network address from the IP address. The default setting is 255.255.255.0.

- Huge TCP/IP networks such as the Internet are often divided up into smaller networks called sub networks. The subnet mask is a 32 bit value that specifies the number of bits of the IP address used to identify the network address. The portion other than the network address is the host address that identifies individual computers on the network.
- Consult your network administrator for the subnet mask value. You may not need to set the value.
- This parameter is automatically configured in environments using DHCP.

- **Default Gateway**

You can set the IP address of the gateway (default gateway) used to communicate with other networks. The default setting is 0.0.0.0.

- The default gateway has control functions that handle protocol exchanges when communicating with multiple networks, so that data transmission is carried out smoothly.
- Consult your network administrator for the default gateway value. You may not need to set the value.
- This parameter is automatically configured in environments using DHCP.

- **DNS (Domain Name System)**

The DNS is a system that correlates the host name/domain name to the IP address. Given AAA.BBBBBB.com, AAA is the host name and BBBBBB.com is the domain name. Instead of using the IP address, which is a sequence of numbers, a host name and domain name can be used to access the network.

- Set the domain name, the DNS server address, and the domain suffix. If DHCP can be used, the address can be automatically assigned.
- When accessing a network drive or a network printer from the WT3000, a name can be used to access the destination rather than an IP address.
- For details, consult your network administrator.

- **Domain name**

- Set the network domain name to which the WT3000 belongs.
- Enter up to 30 characters.
- The characters that can be used are 0-9, A-Z, %, _, () (parentheses), - (minus sign).

- **DNS Server Address**
 - Set the IP address of the DNS server. The default setting is 0.0.0.0.
 - You can specify up to two DNS server addresses, primary and secondary. If the primary DNS server is down, the secondary DNS server is automatically looked up for the mapping of the host name/domain name and IP address.
- **Domain Suffix**
 - When the IP address corresponding to the server name with the domain name specified in the previous section is not found, the system may be set up to search using a different domain name. Enter this alternate domain name as the domain suffix.
 - You can specify up to two domain suffixes, primary and secondary.
- **Setting TCP/IP Parameters for Network Connection**

When connecting the WT3000 to a network, set the TCP/IP parameters as shown below depending on whether the DHCP server and DNS server are available.

	DHCP Server is available	DHCP Server is not available
DHCP	ON	OFF
IP address	Setting not necessary (Automatically set by the DHCP server)	Set manually (supplied by your network administrator)
Subnet mask		Set manually (check with your network administrator)
Default gateway		Set manually (check with your network administrator)

	DHCP Server is available	DHCP Server is not available
DNS	ON	OFF
Domain name	Set manually*	Setting not necessary
DNS server address	Set manually*	Setting not necessary
Domain suffix	Set manually*	Setting not necessary

* If DHCP can be used, these settings can be automatically assigned. For details, consult your network administrator.

- **TCP/IP Configuration Example When a PC and WT3000 Are Connected on an Independent Ethernet Network**

Examples of TCP/IP settings on the WT3000 are shown below. Specify the TCP/IP settings on the PC to comply with the settings in this example as shown in the example given later.

DHCP	OFF
IP address	192.168.21.127
Subnet mask	255.255.255.0
Default gateway	0.0.0.0
DNS	OFF

Note

- If you set the TCP/IP parameters for the first time or change the parameters, restart the WT3000 to apply the new settings.
- If the WT3000 is turned ON with the DHCP function enabled without an Ethernet cable connected, communications and file functions may not operate properly. In such case, turn DHCP OFF and restart the WT3000.

5.2 Setting TCP/IP

Configuring the TCP/IP Settings of the PC

Communication parameters such as the IP address must be specified also on the PC side. Communication parameters are specified for each Ethernet NIC that is installed in the PC. Here, the settings of the NIC required for connecting your PC and the WT3000 are explained.

If the IP address and other parameters are to be assigned dynamically using the DHCP server, the settings below are not necessary.

Select **Obtain an IP address automatically** under the **IP Address** tab of the **TCP/IP Properties** dialog box.

For example, if you are connecting a PC and the WT3000 to an independent Ethernet network, you can specify parameters as indicated in the next table. For details on the parameters, consult your system or network administrator.

Parameter	Value	Note
IP address	Example: 192.168.21.128	IP address for the PC
Subnet mask	Example: 255.255.255.0	Set the same value as the subnet mask that was specified for the WT3000.
Gateway	None	
DNS	Disable	
WINS	Disable	

The following procedure describes the steps for Windows 95/98. For Windows NT/2000 Pro, carry out equivalent steps accordingly.

1. Select **Start > Settings > Control Panel**. The Control Panel opens.
2. Double-click the **Network** icon. The Network dialog box opens.
3. Select **TCP/IP** corresponding to the Ethernet NIC that is connected to your PC and click **Properties**. The TCP/IP Properties dialog box appears.

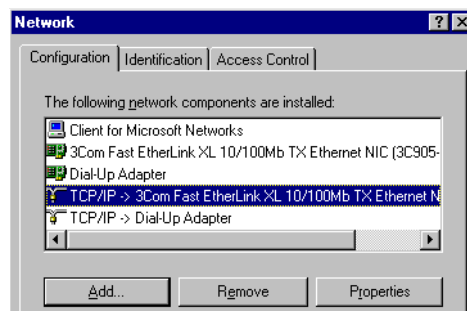

4. Set the parameters such as the IP address according to the previous table and click **OK**.

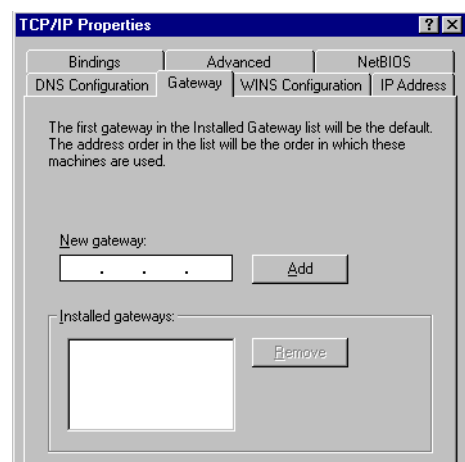
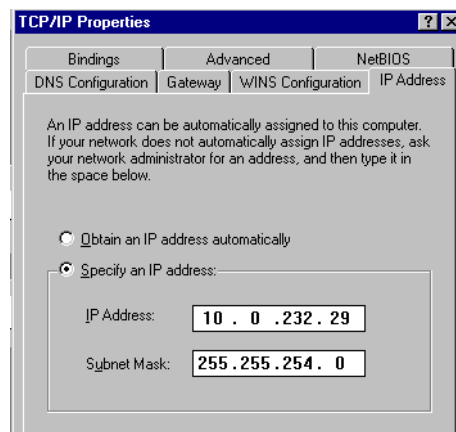

5. Restart your PC.

5.3 Saving Setup, Waveform Display, Numeric, and Image Data to the FTP Server (FTP Client Function)

Procedure

To exit the menu during operation, press **ESC** located above the soft keys.

In the procedural explanation below, the phrase “press the **cursor keys**” may be used. This phrase refers to the procedures for selecting items and entering values and character strings. For details on the procedures, see section 3.14 in the *User's Manual IM760301-01E*.

1. Press **MISC** to display the Misc menu.
2. Press the **Next 1/2** soft key. The Next 2/2 menu appears.
3. Press the **Network** soft key to display the Network menu.

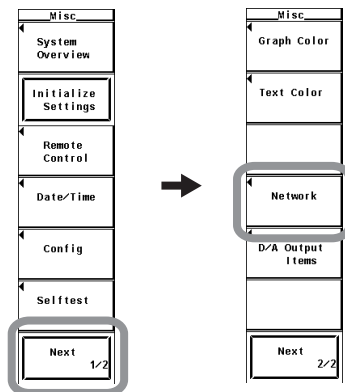

4. Press the **Net Drive Setup** soft key to display the Net Drive Setup dialog box.

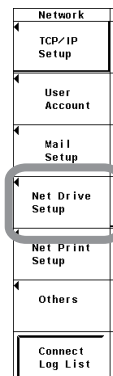



5.3 Saving Setup, Waveform Display, Numeric , and Image Data to the FTP Server (FTP Client Function)

- **Specifying the Save Destination FTP Server**
 5. Press the **cursor keys** to select FTP Server.
 6. Press **SET**. A keyboard appears.
 7. Use the **keyboard** to enter the IP address of the FTP server. If you are using DNS, you can specify the server by name.

For keyboard operations, see section 3.14 in the *User's Manual IM760301-01E*.
- **Entering the Login Name and Password for Accessing the Save Destination FTP Server**
 8. Press the **cursor keys** to select Login Name.
 9. Press **SET**. A keyboard appears.
 10. Use the **keyboard** to enter the login name.

For keyboard operations, see section 3.14 in the *User's Manual IM760301-01E*.
 11. Press the **cursor keys** to select Password.
 12. Press **SET**. A keyboard appears.
 13. Use the **keyboard** to enter the password. A password is not required if the login name is anonymous.

For keyboard operations, see section 3.14 in the *User's Manual IM760301-01E*.
- **Setting the Timeout Value**
 14. Press the **cursor keys** to select Time Out.
 15. Press **SET**. The timeout value entry box appears.
 16. Press the **cursor keys** to set the timeout value.
 17. Press **SET** or **ESC** to close the box.
- **Connecting to/Disconnecting from the Save Destination FTP Server**
 18. Press the **cursor keys** to select Connect or Disconnect.
 19. Press **SET**.
 - If you select Connect and press SELECT, a connection is established to the save destination FTP server. When the connection is made,  is displayed in the upper left corner of the screen.
 - If you select Disconnect and press SELECT, connection to the save destination FTP server is dropped. The  displayed in the upper left corner of the screen disappears.

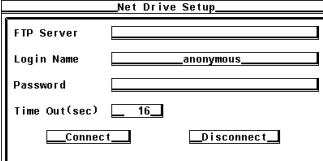

The screenshot shows a dialog box titled "Net Drive Setup". It has four input fields: "FTP Server", "Login Name" (containing "anonymous"), "Password", and "Time Out(sec)" (containing "16"). At the bottom, there are two buttons: "Connect" and "Disconnect".

- **Saving the Data**
 - To save the setup parameters, waveform display data, or numeric data, carry out the save operation according to the procedure given in section 9.3 in the *User's Manual IM760301-01E*.
 - To save the screen image data, carry out the save operation according to the procedure given in section 9.4 in the *User's Manual IM760301-01E*.
 - For the procedure "Selecting the Storage Medium" in section 9.3 in the *User's Manual IM760301-01E*, set the storage medium to **NetWork**.

Explanation

The FTP client function of the WT3000 can be used to save the setup parameters, waveform display data, numeric data, and screen image data to an FTP server on the network in a similar fashion to saving various data on a PC card.

• Save Destination FTP Server

- Specify the FTP server by entering the IP address.
- If you are using DNS (see section 5.2), you can specify the server by name.
- The FTP server program must be running on the PC or workstation that is to become the save destination FTP server. In addition, the following points need attention regarding the server program settings.
 - Set the list output (string returned by the dir command) to UNIX format.
 - Set the home directory and its subdirectories to allow writing.
 - The client cannot move above the home directory.
 - The newest file is not necessarily displayed at the top of the file list.
 - Files and directories that are longer than 8 characters cannot be accessed.
 - Depending on the server, the parent directory symbol "<.. >" may not be displayed.
- The time information in the file list will not be displayed correctly for the following cases.
 - On Windows NT when the time stamp is displayed using am and pm.
 - Servers that return characters other than ASCII characters in the list
- The following operations are not possible from the WT3900 on files that have been saved on an FTP server.
 - Enabling/Disabling file protection, copying, and renaming
 - Formatting the FTP server medium

• Entering the Login Name and Password

Enter the login name and password for accessing the save destination FTP server.

• Login Name

- Enter up to 15 characters.
- The characters that can be used are 0-9, A-Z, %, _ , () (parentheses), - (minus sign).

• Password

- Enter up to 15 characters.
- The characters that can be used are 0-9, A-Z, %, _ , () (parentheses), - (minus sign).

• Setting the Timeout Value

When an FTP server is accessed from the WT3000 and connection cannot be established after a certain period of time (timeout value), the WT3000 decides that the connection to the FTP server is not possible and closes the connection.

You can set the timeout value in the range of 0 to 3600 s. The default value is 15 s.

Note

- The LPR client function cannot be used under the following cases.
 - When the WT3000 is performing file operations (see chapter 9 in the *User's Manual IM760301-01E*).
 - When the WT3000 is being accessed by a PC or workstation on the network (FTP server function, see section 5.6).
- To use the FTP client function, you must configure TCP/IP (see section 5.2) in advance.
- To apply new settings that are made while the connection is up, drop the connection using Disconnect and reconnect.
- If a connection is dropped by the server while you are operating the FTP client, the connection will be automatically reestablished when you display the File List dialog box through file operation as described in chapter 9 in the *User's Manual IM760301-01E*.

5.4 Printing Screen Images on a Network Printer

Procedure

To exit the menu during operation, press **ESC** located above the soft keys.

In the procedural explanation below, the phrase “press the **cursor keys**” may be used. This phrase refers to the procedures for selecting items and entering values and character strings. For details on the procedures, see section 3.14 in the *User's Manual IM760301-01E*.

1. Press **MISC** to display the Misc menu.
2. Press the **Next 1/2** soft key. The Next 2/2 menu appears.
3. Press the **Network** soft key to display the Network menu.

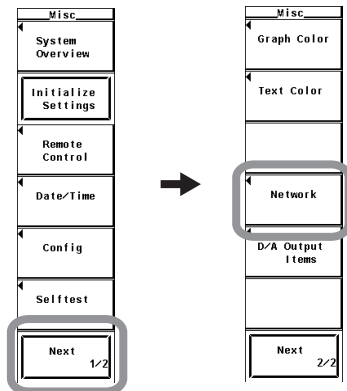

4. Press the **Net Print Setup** soft key to display the Net Print Setup dialog box.

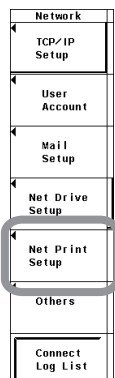

- **Specifying the Printer Server**

5. Press the **cursor keys** to select LPR Server.
6. Press **SET**. A keyboard appears.
7. Use the **keyboard** to enter the IP address of the printer server. If you are using DNS, you can specify the server by name.

For keyboard operations, see section 3.14 in the *User's Manual IM760301-01E*.

- **Entering the Printer Name**

8. Press the **cursor keys** to select LPR Name.
9. Press **SET**. A keyboard appears.
10. Use the **keyboard** to set the printer name.

For keyboard operations, see section 3.14 in the *User's Manual IM760301-01E*.

- **Setting the Output Destination to a Network Printer**

1. Press **SHIFT+PRINT (MENU)** to display the Print menu.
2. Press the **Print to** soft key to display the Print to menu.
3. Press the **Net Print** soft key.

- **Selecting the Output Command**

4. Press the **Format** soft key to display the Format menu.
5. Press any soft key from **BJ** to **LIPS3** to select the output command.
If you selected BJ, proceed to step 6.
If you selected PCL5, proceed to step 8 on the next page.
If you selected LIPS3, proceed to step 9 on the next page.

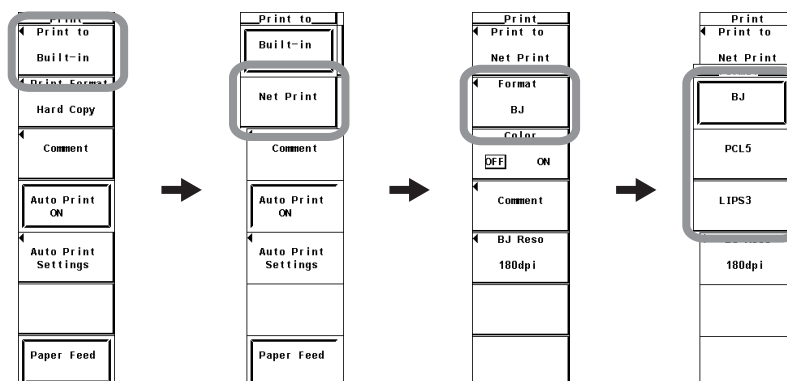

5.4 Printing Screen Images on a Network Printer

- **Selecting the Resolution**

(This procedure is applicable if you selected BJ in step 5.)

6. Press the **BJ_Reso** soft key to display the Resolution menu.
7. Press any soft key from **180dpi** to **360dpi** to select the resolution

- **Turning ON/OFF the Color Output**

(This procedure is applicable if you selected BJ, or PCL5 in step 5.)

8. Press the **Color** soft key to select ON or OFF.

- **Setting Comments**

9. Press the **Comment** soft key. A keyboard appears.
10. Use the **keyboard** to enter the comment.

For keyboard operations, see section 3.14 in the *User's Manual IM760301-01E*.

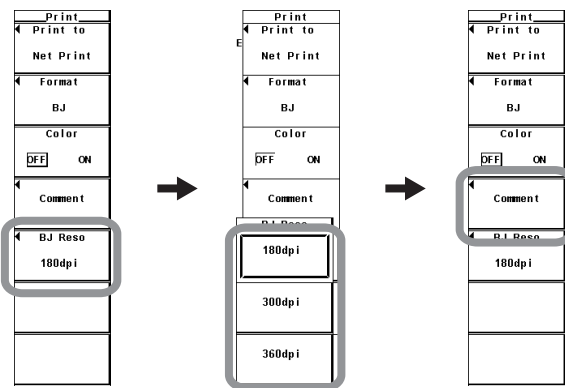

- **Executing the Print Operation**

11. Switch to the screen you wish to print.
12. Press the **PRINT** soft key. The screen image is printed.

- **Canceling the Print Operation**

13. Press the **Abort** soft key in the Print menu.

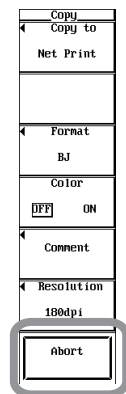

Explanation

The LPR client function of the WT3000 can be used to output screen images to a network printer.

- **Printer Server**

- Specify the printer server by entering the IP address.
- If you are using DNS (see section 5.2), you can specify the server by name.

- **Printer Name**

Enter the name of the output destination printer on the network.

- **Selecting the Output Command**

Select the output command type from the choices below.

- BJ
- PCL5
- LIPS3

- **Turning ON/OFF Color Printing**

You can select whether to output the image in color when the output command type is BJ, or PCL5.

- **ON**

The displayed screen image can be output to a printer in color (256 colors).

- **OFF**

The displayed screen image can be output to a printer in black and white.

- **Setting Comments**

Same as the explanation given in "File Name and Comment" in section 9.3 in the *User's Manual IM760301-01E*.

Note

- The LPR client function cannot be used under the following cases.
 - When the WT3000 is performing file operations (see chapter 9 in the *User's Manual IM760301-01E*).
 - When the WT3000 is being accessed by a PC or workstation on the network (FTP server function, see section 5.6).
- To use the LPR client function, you must configure TCP/IP (see section 5.2) in advance.
- Output is possible to printers that support the TCP/IP protocol.

5.5 Sending E-mail

Procedure

To exit the menu during operation, press **ESC** located above the soft keys.

In the procedural explanation below, the phrase “press the **cursor keys**” may be used. This phrase refers to the procedures for selecting items and entering values and character strings. For details on the procedures, see section 3.14 in the *User's Manual IM760301-01E*.

1. Press **MISC** to display the Misc menu.
2. Press the **Next 1/2** soft key The Next 2/2 menu appears.
3. Press the **Network** soft key to display the Network menu.

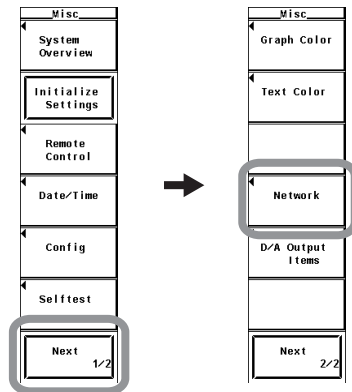

4. Press the **Mail Setup** soft key to display the Mail Setup dialog box.

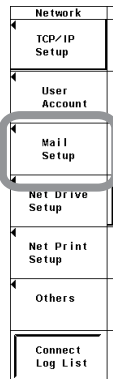

- **Specifying the Mail Server**

5. Press the **cursor keys** to select Mail Server.
6. Press **SET**. A keyboard appears.
7. Use the **keyboard** to enter the IP address of the mail server. If you are using DNS, you can specify the server by name.

For keyboard operations, see section 3.14 in the *User's Manual IM760301-01E*.

- **Entering the Destination Mail Address**

8. Press the **cursor keys** to select Mail Address.
9. Press **SET**. A keyboard appears.
10. Use the **keyboard** to enter the destination mail address.

For keyboard operations, see section 3.14 in the *User's Manual IM760301-01E*.

- **Setting Comments**

(Enter a comment as necessary.)

11. Press the **cursor keys** to select Comment.
12. Press **SET**. A keyboard appears.
13. Use the **keyboard** to enter the comment.

For keyboard operations, see section 3.14 in the *User's Manual IM760301-01E*.

The screenshot shows a window titled "Mail Setup" with the following fields and controls:

- Mail Server: []
- Mail Address: []
- Comment: []
- MailBaseTime: [0]:[0]:[0] Interval [OFF]
- Mail Test: []

- **Setting the Time of Transmission**

14. Press the **cursor keys** to select the hour, minute, or second box of MailBaseTime.
15. Press **SET**. An entry box appears.
16. Press the **cursor keys** to set the hour, minute, or second that you selected in step 14.
17. Press **SET** or **ESC** to close the box.
18. Repeat steps 14 to 17 to set the hour, minute, and second.

The screenshot shows the "Mail Setup" window with a small box over the hour digit of the MailBaseTime field, indicating that the user is editing the time.

- **Selecting the Transmission Interval**

19. Press the **cursor keys** to select Interval.
20. Press **SET**. An entry box appears.
21. Press the **cursor keys** to select OFF or 1h to 24h.
If you select OFF, mails are not transmitted.
22. Press **SET** or **ESC** to close the box.

- **Performing a Test Transmission**

23. Press the **cursor keys** to select Mail Test.
24. Press **SET**. A test mail is sent to the destination.

Explanation

The condition of the WT3000 can be sent in e-mail messages at a certain interval to a specified mail destination.

- **Mail Server**

- Specify the mail server by entering the IP address.
- If you are using DNS (see section 5.2), you can specify the server by name.

- **Transmission Destination Mail Address**

Enter the mail address of the device that is to receive the messages sent by the WT3000.

- **Setting Comments**

Same as the explanation given in “File Name and Comment” in section 9.3 in the *User's Manual IM760301-01E*.

- **Setting the Time of Transmission**

- Specify the time to start transmitting the e-mail messages.
- Set the time in units of hour : minute : second in the following range.
0:0:0 to 23:59:59

- **Selecting the Transmission Interval**

- Specify the interval for transmitting the e-mail messages.
- You can select the measurement range from the following: If you select OFF, mails are not transmitted.
OFF, 1h, 2h, 3h, 4h, 6h, 8h, 12h, and 24h

- **Transmitted Information of the WT3000**

Number of Displayed Items	Transmitted Data
4 Items	All numeric data on pages 1 to 9 on the screen (36 data values)
8 Items	All numeric data on pages 1 to 9 on the screen (72 data values)
16 Items	All numeric data on pages 1 to 9 on the screen (144 data values)
All Items Single List Dual List	The numeric data of measurement functions that are selected in “Saving Numeric Data” of the data save/load function is transmitted. For details on saving numeric data, see section 9.3 in the <i>User's Manual IM760301-01E</i> .

Note

- To use the SMTP client function, you must set TCP/IP (see section 5.2) and the time difference from GMT (Greenwich Mean Time) or SNTp (see section 5.7) in advance.
- The sender (From) address of the mail messages sent by the WT3000 is the same as the specified recipient address.
- E-mail cannot be transmitted when the transmission interval is set to OFF.

- **Limitations by Measurement Modes**

You cannot send mail in IEC harmonics measurement, voltage fluctuation and flicker measurement, and cycle-by-cycle measurement modes.

5.6 Accessing the WT3000 from a PC or Workstation (FTP Server Function)

Procedure

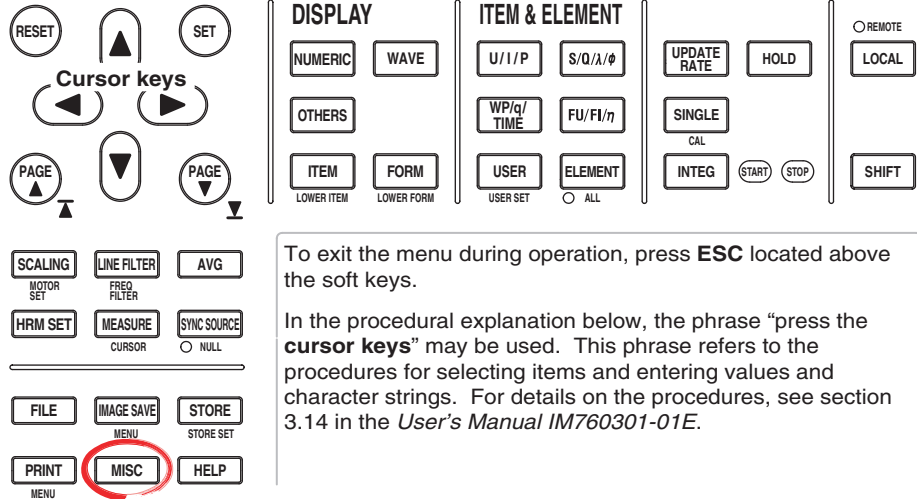

The FTP server function can be used when a PC card or USB storage is connected to the WT3000.

1. Press **MISC** to display the Misc menu.
2. Press the **Next 1/2** soft key to display the Next 2/2 menu.
3. Press the **Network** soft key to display the Network menu.

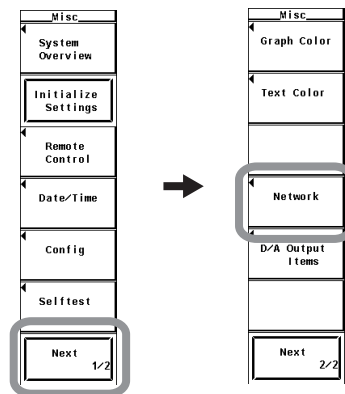

4. Press the **User Account** soft key to display the User Account dialog box.

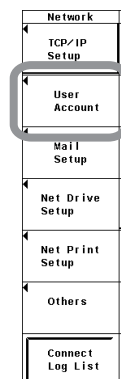

5.6 Accessing the WT3000 from a PC or Workstation (FTP Server Function)

- **Setting the User Name**

5. Press the **cursor keys** to select User Name.
6. Press **SET** to display the keyboard.
7. Use the **keyboard** to enter the user name.
 - For keyboard operations, see section 3.14 in the *User's Manual IM760301-01E*.
 - When not restricting the access, specify anonymous. If you specify anonymous, you do not have to set the password.

- **Setting the Password**

(If you set user name to anonymous in step 7, you do not have to set the password.)

8. Press the **cursor keys** to select Password.
9. Press **SET** to display the keyboard.
10. Use the **keyboard** to enter the password.

For keyboard operations, see section 3.14 in the *User's Manual IM760301-01E*.

- **Setting the Timeout Value**

11. Press the **cursor keys** to select Time Out.
12. Press **SET** to display the timeout time selection box.
13. Press the **cursor keys** to set the timeout value.
14. Press **SET** or **ESC** to close the box.

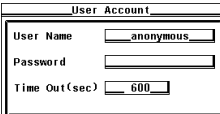

The screenshot shows a window titled "User Account" with three input fields: "User Name" containing "anonymous", "Password" which is empty, and "Time Out(sec)" containing "600".

- **Accessing the WT3000**

15. Execute an FTP client on the PC or workstation.
16. Access the WT3000 using the user name and password specified in the previous section.

- **Displaying the Logging List**

17. Press the **Connect Log List** soft key. The WT3000 access log is displayed.

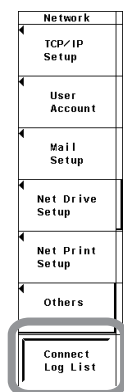

Explanation

You can access the PC card in the WT3000 or USB memory (option) from a PC or workstation on the network.

To access the WT3000, a FTP client is needed on the PC or workstation.

- **Setting the User Name**

- Enter the user name to allow access to the WT3000.
- Enter up to 15 characters.
- The characters that can be used are 0-9, A-Z, %, _ , () (parentheses), - (minus sign).
- If you specify anonymous, the WT3000 can be accessed from the outside (PC or workstation) without a password.

- **Setting the Password**

- Enter the password for the user name to allow access to the WT3000.
- Enter up to 15 characters.
- The characters that can be used are 0-9, A-Z, %, _ , () (parentheses), - (minus sign).
- If the user name is set to anonymous, the WT3000 can be accessed from the outside (PC or workstation) without a password.

- **Setting the Timeout Value**

The WT3000 closes the connection to the network if there is no access for a certain period of time (timeout value).

You can set the timeout value in the range of 0 to 3600 s. The default value is 60 s.

- **Logging List**

The access log of the WT3000 can be displayed. The data and time, user name, and IP address of the 25 most recent accesses are displayed.

5.6 Accessing the WT3000 from a PC or Workstation (FTP Server Function)

Note

- The WT3000 supports only a single client.
 - When the WT3000 is accessed from the PC or workstation (login),  is displayed in the upper left corner of the screen.
 - The FTP server function cannot be used under the following cases.
 - When the WT3000 is accessing a PC or workstation on the network (FTP client function, see section 5.3).
 - When the WT3000 is outputting to a network printer (LPR client function, see section 5.3).
 - When the WT3000 is performing file operations (see chapter 9 in the *User's Manual IM760301-01E*).
 - The PC card, USB storage, and network drive are displayed as [PC_Card], [USB], and [ND0], respectively, at the root directory of the PC or workstation accessing the WT3000.
 - The log list is cleared when the power is turned OFF.
 - When using the FTP server function, set the TCP/IP parameters according to section 5.2, "Setting the Ethernet Interface (TCP/IP)."
 - To apply new settings, the WT3000 must be power cycled.
-

5.7 Setting of the Time Difference from GMT or SNTP

Procedure

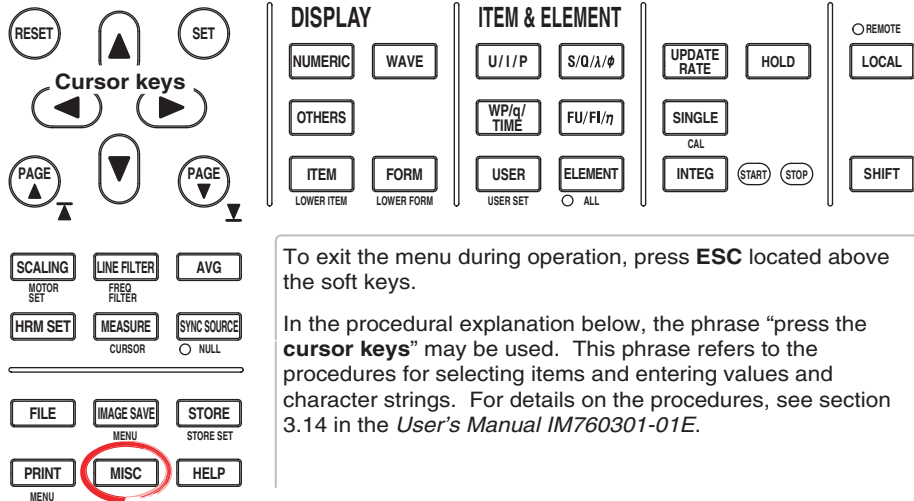

1. Press **MISC** to display the Misc menu.
2. Press the **Next 1/2** soft key to display the Next 2/2 menu.
3. Press the **Network** soft key to display the Network menu.
4. Press the **Others** soft key to display the Others dialog box.

• Setting the Time Difference from GMT (Greenwich Mean Time)

5. Press the **cursor keys** to select Time Hour under Time Difference from GMT.
6. Press **SET** to display the entry box.
7. Press the **cursor keys** to set the hour in the range of -12 to 13.
8. Press **SET** to confirm.
9. Likewise, set the minute in the range of 0 to 59.

Note

Minute can be specified only if Time Hour is set in the range of -11 to 12. (Minute cannot be specified if Time Hour is set to -12 or 13.)

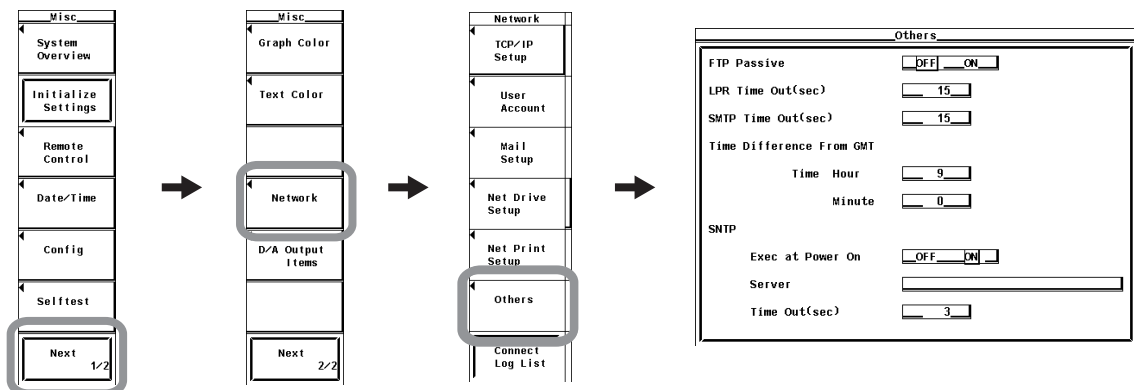

5.7 Setting of the Time Difference from GMT or SNTP

- **Setting SNTP (Simple Network Time Protocol)**

10. Press the **cursor keys** to select Exec at Power On under SNTP.
11. Press **SET** to select ON or OFF.
12. Press the **cursor keys** to select Server.
13. Press **SET** to display the keyboard.
14. Use the keyboard to enter the IP address of the SNTP server.
15. Press **ESC** to close the dialog box.
16. Press the **cursor keys** to select Time Out.
17. Press **SET** to display the entry box.
18. Press the **cursor keys** to set the timeout value in the range of 1 to 60 (s).
19. Press **SET** to confirm.

- **Restarting the WT3000**

If Exec at Power On is ON, restart the WT3000 to synchronize the time with the SNTP server.

Explanation

Set the time difference from GMT (Greenwich Mean Time).

- **Setting of the time difference from GMT**

Set the time difference in the range of –12 hours 00 minutes to 13 hours 00 minutes. For example, Japan standard time is ahead of GMT by 9 hours. In this case, set Time Hour to 9 and Minute to 00.

- **Checking the Standard Time**

Check the standard time for the region where the WT3000 is to be used using one of the following methods.

- Check the date and time settings on your PC (Windows).
- Check the site at the following URL:<http://www.worldtimeserver.com/>

Note

The WT3000 does not support Daylight Savings Time. To set the Daylight Savings Time, adjust the time difference from GMT.

- **Setting SNTP**

If Exec at Power On is ON, the WT3000 synchronizes with the SNTP server clock that is connected to the network when the power is turned ON.

Note

- If the time difference from GMT (Greenwich Mean Time) is specified, the time is set to a value derived by calculating the difference between the time retrieved from the SNTP server and the time difference.
 - It is possible to synchronize with the time on an SNTP server when setting the date/time of the WT3000. For details, see section 3.12 in the *User's Manual IM760301-01*.
 - If you do not want to synchronize with the time on an SNTP server, do not set the IP address of the SNTP server.
-

5.9 Setting the FTP Passive Mode and LPR/SMTP Timeout

Procedure

The diagram shows the control panel with several sections of soft keys:

- Cursor keys:** RESET, SET, and four arrow keys (up, down, left, right).
- DISPLAY:** NUMERIC, WAVE, OTHERS, ITEM (LOWER ITEM), FORM (LOWER FORM).
- ITEM & ELEMENT:** U/I/P, S/Q/A/φ, WP/q/TIME, FU/FI/η, USER (USER SET), ELEMENT (ALL).
- UPDATE RATE:** UPDATE RATE, HOLD, LOCAL (with REMOTE indicator).
- Other keys:** SCALING (MOTOR SET), LINE FILTER (FREQ. FILTER), AVG, HRM SET, MEASURE (CURSOR), SYNC SOURCE (NULL), FILE (MENU), IMAGE SAVE (MENU), STORE (STORE SET), PRINT (MENU), MISC (MENU), HELP.

To exit the menu during operation, press **ESC** located above the soft keys.

In the procedural explanation below, the phrase “press the **cursor keys**” may be used. This phrase refers to the procedures for selecting items and entering values and character strings. For details on the procedures, see section 3.14 in the *User’s Manual IM760301-01E*.

1. Press **MISC** to display the Misc menu.
2. Press the **Next 1/2** soft key. The Next 2/2 menu appears.
3. Press the **Network** soft key to display the Network menu.

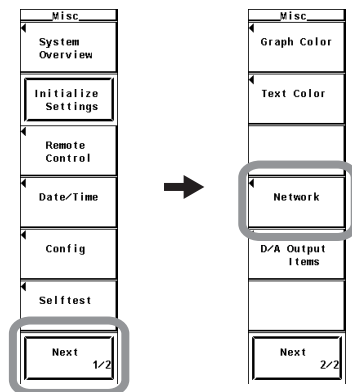

4. Press the **Others** soft key to display the Others dialog box.

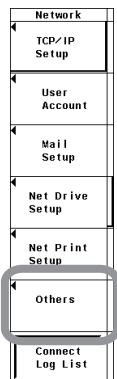

- **Turning ON/OFF the FTP Passive Mode**
 5. Press the **cursor keys** to select FTP Passive.
 6. Press **SET** to select ON or OFF.
- **Setting the LPR Timeout Value**
 5. Press the **cursor keys** to select LPR Time Out.
 6. Press **SET**. The timeout value entry box appears.
 7. Press the **cursor keys** to set the timeout value.
 8. Press **SET** or **ESC** to close the box.
- **Setting the SMTP Timeout Value**
 5. Press the **cursor keys** to select SMTP Time Out.
 6. Press **SET**. The timeout value entry box appears.
 7. Press the **cursor keys** to set the timeout value.
 8. Press **SET** or **ESC** to close the box.

The screenshot shows a configuration window titled 'Others' with the following settings:

FTP Passive	<input type="checkbox"/> OFF <input checked="" type="checkbox"/> ON
LPR Time Out(sec)	<input type="text" value="15"/>
SMTP Time Out(sec)	<input type="text" value="15"/>
Time Difference From GMT	
Time Hour	<input type="text" value="9"/>
Minute	<input type="text" value="0"/>
SNIP	
Exec at Power On	<input type="checkbox"/> OFF <input checked="" type="checkbox"/> ON
Server	<input type="text"/>
Time Out(sec)	<input type="text" value="3"/>

Explanation

Special settings related to the FTP client, LPR, and SMTP are entered. Set these items as necessary.

- **Turning ON/OFF the FTP Passive Mode**

Turn this function ON when using the WT3000 behind a firewall* that requires the passive mode. The default setting is OFF.

* A firewall is furnished on a system that has security features. It prevents intrusion from the outside into the network system.
- **Setting the LPR Timeout Value**

The WT3000 closes the connection to the printer if there is no response from the printer for a certain period of time (timeout time) while it attempts to access the printer. You can set the timeout value in the range of 0 to 3600 s. The default value is 15 s.
- **Setting the SMTP* Timeout Value**

When a mail server is accessed from the WT3000 and connection cannot be established after a certain period of time (timeout time), the WT3000 decides that the connection to the mail server is not possible and closes the connection. You can set the timeout value in the range of 0 to 3600 s. The default value is 15 s.

* SMTP (Simple Mail Transfer Protocol) is a protocol that resides above the TCP/IP layer and is used by the e-mail transmission system.

5.10 Ethernet Interface Specifications

Item	Specifications
Number of communication ports	1
Connector type	RJ-45 connector
Electrical and mechanical specifications	Conforms to IEEE 802.3.
Transmission system	Ethernet (100BASE-TX/10BASE-T)
Data rate	100 Mbps maximum
Communication protocol	TCP/IP
Supported service	FTP client Save setup parameters, waveform display data, numeric data, and screen image data to an FTP server (network drive) on the network. Load the setup parameters that have been saved to the FTP server. FTP server Access the WT3000 from a PC or workstation on the network and download the file on the PC card or USB memory in the WT3000. However, an FTP client is needed on the PC or workstation. LPR client (network printer) Print the screen image on a network printer. SMTP client (mail transmission) Periodically transmit the information of the WT3000 to a specified mail address. DHCP DNS Remote control The WT3000 can be controlled remotely from a host such as a PC. For details, see the <i>Communication Interface User's Manual (IM760301-17E)</i> .

TCP Port Numbers that the WT3000 Uses

Port Number	Description	Function
20	File Transfer [Default Data]	FTP server and FTP client*
21	File Transfer [Control]	FTP server and FTP client
25	Simple Mail Transfer Protocol	SMTP client
515	–	LPR client
10001	–	Instrument control via the Ethernet interface

UDP Port Numbers that the WT3000 Uses

Port Number	Description	Function
53	Domain Name Server	DNS client
67	Bootstrap Protocol Server	DHCP client
68	Bootstrap Protocol Client	(receive wait port)
123	Network Time Protocol	SNTP client

* The port number when FTP passive mode (see section 5.9) is turned OFF. If FTP passive mode is turned ON, the port number is arbitrary.
If FTP passive mode is OFF, connection is established from the server. If you are connecting the WT3000 behind a firewall, turn FTP passive mode ON.
For the procedure of changing the FTP passive mode, see section 5.9.

6.1 Delta Computation Function

Functional Overview

The sum or difference of the instantaneous values (sampled data) of the voltage or current between the elements in a wiring unit can be used to determine various types of data such as the differential voltage and phase voltage. This operation is called delta computation.

Delta computation enables the following computations.

- The differential voltage and differential current between two elements can be computed on a single-phase, three-wire system or a three-phase, three-wire system (using two elements).
- The line voltage and phase current that are not measured on a single-phase, three-wire system or a three-phase, three-wire system (using 2 elements) can be computed.

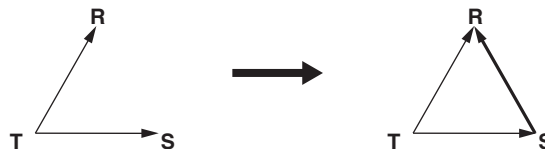

- Using the data from a three-phase, four-wire system, various data of a delta connection can be computed from the data of a star connection (star-delta transformation).

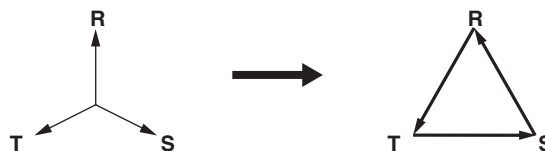

- Using the data from a three-phase, three-wire (three-voltage, three-current) system, various data of a star connection can be computed from the data of a delta connection (delta-star transformation). This function is effective when you wish to observe the phase voltage of an object that has no neutral line such as a motor.



For the equations, see section 6.3.

Limitations by Measurement Modes

Delta computation cannot be performed in the following measurement modes.

- Wide bandwidth harmonic measurement mode
- IEC harmonic measurement mode
- Voltage fluctuation and flicker measurement mode
- Cycle-by-cycle measurement mode

6.2 Setting the Delta Computation

Procedure

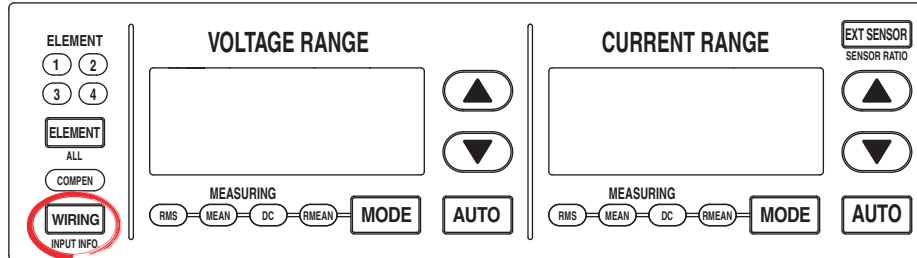

To exit the menu during operation, press **ESC** located above the soft keys.

In the procedural explanation below, the phrase “press the **cursor keys**” may be used. This phrase refers to the procedures for selecting items and entering values and character strings. For details on the procedures, see section 3.14 in the *User's Manual IM760301-01E*.

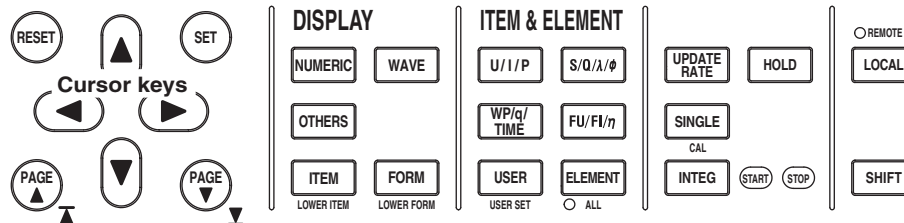

1. Press **WIRING** to display the Wiring menu.
 2. Press the **ΔMeasure** soft key to display the ΔMeasure dialog box.
- **Selecting the Target Wiring Unit for the Delta Computation**
 3. Press the **cursor keys** to select the wiring unit.
(This step may not be necessary depending on the wiring system.)
 4. Press **SET** to confirm. A type selection box appears.
 - **Selecting the Delta Computation Type**
 5. Press the **cursor keys** to select the delta computation type.
(The menu varies depending on the wiring system.)
 6. Press **SET** to confirm.

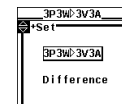
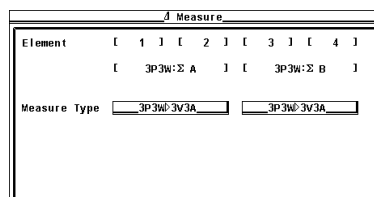
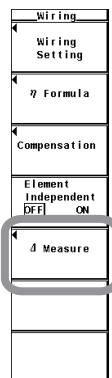

Explanation

In the normal measurement of U and I, the sum or difference of the instantaneous values (sampled data) of the voltage or current between the elements assigned to the target wiring unit for the delta computation can be used to determine the measurement functions, ΔU and ΔI . This operation is called delta computation. For the equations, see section 6.3. The measurement period is the same as that described in section 2.2, "Measurement Function and Measurement Period" in the *User's Manual IM760301-01E*.

- **Selecting the Target Wiring Unit for the Delta Computation**

The wiring units for delta computation can be selected only on models with 4 input elements installed when the wiring system combination is as follows:

- Input elements 1 and 2 are set to 1P3W or 3P3W (ΣA).
- Input elements 2 and 3 are set to 1P3W or 3P3W (ΣA).
- Input elements 3 and 4 are set to 1P3W or 3P3W (ΣB).

- **Selecting the Delta Computation Type**

You can select the delta computation type from the choices below. The selectable items vary depending on the selected wiring system pattern.

Wiring system	Selectable delta computation type
1P3W	Difference, 3P3W>3V3A
3P3W	Difference, 3P3W>3V3A
3P4W	Star>Delta
3P3W(3V3A)	Delta>Star

- **Difference**

Computes the differential voltage and differential current between two elements.

When Difference is specified for wiring unit ΣA

$$\Delta F1[U_{diffA}]$$

$$\Delta F2[I_{diffA}]$$

When Difference is specified for wiring unit ΣB

$$\Delta F3[U_{diffB}]$$

$$\Delta F4[I_{diffB}]$$

- **3P3W>3V3A**

Computes other data when the wiring system is changed from three-phase, three-wire (3P3W) to three-voltage, three-current (3V3A).

When 3P3W>3V3A is specified for wiring unit ΣA

$$\Delta F1[U_{rsA}]$$

$$\Delta F2[I_{tA}]$$

When 3P3W>3V3A is specified for wiring unit ΣB

$$\Delta F3[U_{rsB}]$$

$$\Delta F4[I_{tB}]$$

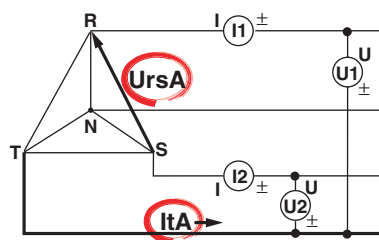

6.2 Setting the Delta Computation

- **Star>Delta**

Computes various data of a delta connection from the data of a star connection (star-delta transformation) using the data from a three-phase, four-wire system.

$\Delta F1[UrA]$

$\Delta F2[UsA]$

$\Delta F3[UtA]$

$\Delta F4[InA]$

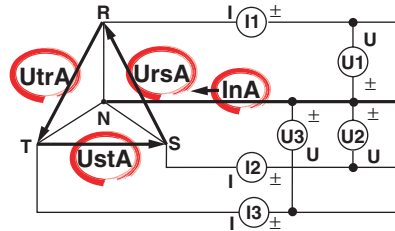

- **Delta>Star**

Computes various data of a star connection from the data of a delta connection (delta-star transformation) using the data from a three-voltage, three-current system. The neutral point of the star connection is computed as a centroid of the delta connection. If the actual neutral point does not match the centroid, an error results.

$\Delta F1[UrA]$

$\Delta F2[UsA]$

$\Delta F3[UtA]$

$\Delta F4[InA]$

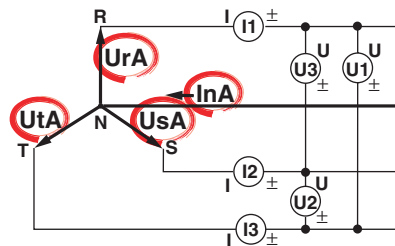

Note

- It is recommended that the measurement range and scaling (VT/CT ratio and coefficients) of the elements that are being computed (delta computation) be set the same as much as possible. Using a different measurement range or scaling causes the measurement resolution of the sampled data to be different. In effect, the computation result will have errors.
- The number (1, 2, 3, and 4) that is attached to the measurement function symbol of the delta computation has no relation to the element number. The computation of the measurement functions $\Delta F1$ to $\Delta F4$ of delta computation varies depending on the wiring system and the delta computation type. For details, see section 6.3.
- On models with a single element, this function does not work. Therefore, the setup menus do not appear.
- If the target wiring system for delta computation is a single-phase, two-wire system (1P2W), delta computation cannot be performed.

6.3 Determination of Delta Computation

Delta Computation Type, Sampled Data, and Measurement Function of Delta Computation

The sampled data in the table are substituted in the equations of the voltage U and current I^{*}, and the computed result is determined. The synchronization source for the delta computation is the synchronization source (Sync Src) that is assigned to the first input element (smallest number) of the wiring unit on which delta computation is to be performed.

Delta Computation Type	Sampled Data Substituted into the Voltage U and Current I Equations*		Data Determined with the Delta Computation and Their Measurement Function Symbols		Note
	u(n)	i(n)			
difference	$u_1 - u_2$	$i_1 - i_2$	Differential voltage Differential current	$\Delta F1[U_{diffA}]$ $\Delta F2[I_{diffA}]$	—
3P3W ▷3V3A	$u_1 - u_2$	$-i_1 - i_2$	Line voltage between phase R and S Line current of phase T	$\Delta F1[U_{rsA}]$ $\Delta F2[I_{tA}]$	Assumptions $i_1 + i_2 + i_3 = 0$
Delta ▷Star	$u_1 - \frac{(u_1+u_2)}{3}$	—	Phase voltage of each phase	$\Delta F1[U_{rA}]$	Assumptions The centroid of the delta connection is computed as the neutral point of the star connection.
	$u_2 - \frac{(u_1+u_2)}{3}$	—		$\Delta F2[U_{sA}]$	
	$-\frac{(u_1+u_2)}{3}$	—		$\Delta F3[U_{tA}]$	
	—	$i_1 + i_2 + i_3$	Line current of the neutral line	$\Delta F4[I_{nA}]$	
Star ▷Delta	$u_1 - u_2$	—	Line voltage of each phase	$\Delta F1[U_{rsA}]$	—
	$u_2 - u_3$	—		$\Delta F2[U_{stA}]$	
	$u_3 - u_1$	—		$\Delta F3[U_{trA}]$	
	—	$i_1 + i_2 + i_3$	Line current of the neutral line	$\Delta F4[I_{nA}]$	

* Voltage U and current I equations in appendix 1, "Symbols and Determination of Measurement Functions" in the *User's Manual IM760301-01E*.

Note

- The wiring unit on which to perform delta computation can be selected from ΣA and ΣB. The input element that is assigned to the selected element is the element on which delta computation is performed. The numbers 1, 2, and 3 that are attached to sampled data u and i in the above table indicate that elements 1, 2, and 3 are target elements on which delta computation is performed. If the target elements of delta computation are 2, 3, and 4, replace the numbers 1, 2, and 3 that are attached to sampled data u and i with 2, 3, and 4, respectively.
- u₁, u₂, u₃ denote the sampled data of voltage of elements 1, 2, and 3, respectively. i₁, i₂, and i₃ denote the sampled data of current of elements 1, 2, and 3, respectively.
- The number (1, 2, 3, and 4) that is attached to the measurement function symbol of the delta computation has no relation to the element number.
- It is recommended that the measurement range and scaling (transformation ratio and coefficients) of the elements on which delta computation is performed be set the same as much as possible. Using a different measurement range or scaling causes the measurement resolution of the sampled data to be different. In effect, the computation result will have errors.

6.4 Delta Computation Specifications

Item	Specifications
difference	Differential voltage and differential current determined by computation
3P3W→3V3A	Line voltage and phase current that are not measured but can be computed for a three-phase, three-wire system
DELTA→STAR	Line voltage and neutral line current that can be computed for a three-phase, three-wire (3V3A) system
STAR→DELTA	Neutral line voltage and neutral line current that can be computed for a three-phase, four-wire system

7.1 Harmonic Measurement Function

Harmonic measurement can be used to measure the harmonic components of the voltage, current, and power as well as measurement functions such as the phase angle of each harmonic order with respect to the fundamental signal. It can also be used to compute the harmonic distortion of the voltage and current.

Harmonic Measurement Types

Three types of harmonic measurement below can be performed when the advanced computation (/G6) option is installed in the WT3000. Switch the measurement mode according to your application.

- **Harmonic Measurement in Normal Measurement Mode**

Various functions such as integration, waveform display, trend display, and efficiency computation can be used simultaneously with the harmonic measurement. In addition, the rms voltage and current are the total of the rms values of all frequency components in the measurement frequency bandwidth. This rms value and harmonics can be measured simultaneously.

*1 Equivalent to the /G5 (harmonic measurement) option. This harmonic measurement does not conform to IEC61000-3-2.

- **Wide Bandwidth Harmonic Measurement Mode**

Harmonic measurement up to 50th order can be performed on a signal with a 1-kHz fundamental frequency. Use this mode for harmonic measurement of signals whose fundamental frequency is higher than the commercial power supply frequency. By applying an external sampling clock, harmonics can be measured on low frequency signals with a fundamental frequency of 0.1 Hz. The harmonics of inverters that drive motors at low frequency (low revolution) can be measured.

- **IEC Harmonic Measurement Mode**

This mode in combination with the Harmonic/Flicker Measurement Software sold separately allows you to perform harmonic measurement conforming to IEC61000-3-2. Use this mode to check that the harmonics of electric home appliances and office automation equipment comply with the IEC standards.

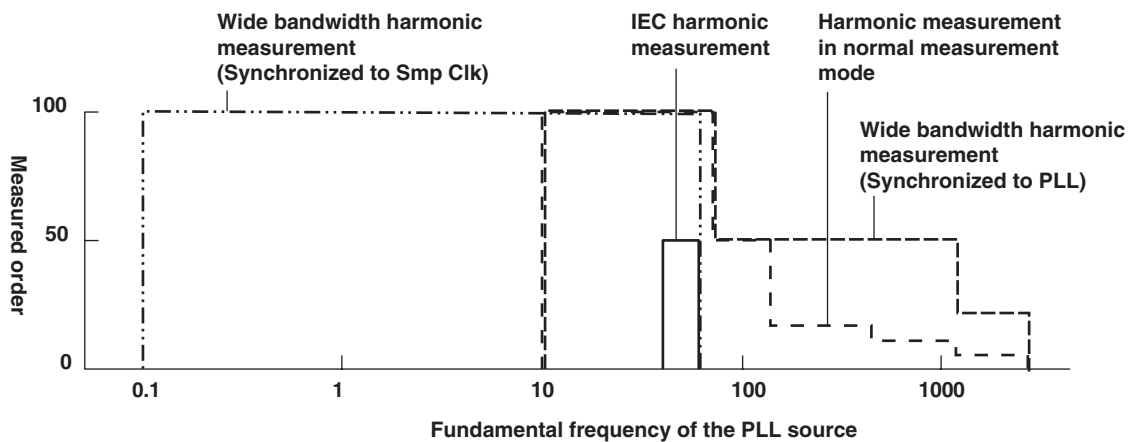

Measurement frequency and order in each measurement mode on models with the advanced computation (/G6) option (when the anti-aliasing filter is OFF)

Functional Limitations by Measurement Modes

Wide bandwidth harmonic measurement mode and IEC harmonic measurement mode perform internal computation differently from other measurement modes in order to achieve the respective harmonic measurement functions. Therefore, some functions such as waveform or bar graph display on the screen, store function, motor evaluation function (motor version) cannot be used in these measurement modes. In addition, some measurement functions such as peak measurement, integration, and efficiency computation cannot be carried out. For a list of functions with limitations and measurement functions that cannot be measured, see appendices 10 and 11 in the *User's Manual IM760301-01E*.

Relationship between the Rms Values of Voltage U/Current I and Measurement Modes

The rms values of voltage U and current I consist of two types: normal measurement value and total value. The computing method and display of these values vary depending on the measurement mode as shown below. The normal measured value and total value cannot be measured simultaneously.

	Normal Measured Value	Total Value
Measurement mode	Normal measurement mode Waveform computation mode FFT mode Voltage fluctuation and flicker measurement mode Cycle-by-cycle measurement mode	Wide bandwidth harmonic measurement mode IEC harmonic measurement mode
Computing method	Compute the average based on the sampling data in the measurement period For details, see appendix 1, in the <i>User's Manual IM760301-01E</i> .	Total value of the components of each order between the minimum order and maximum order that are specified in the setup menu of the measured order of harmonic measurement. For details, see section 7.10.
Characteristics	Total value of all frequency components in the measurement frequency bandwidth	Value that excludes rms components of orders outside the specified order range and rms components that are not integer multiples of the fundamental frequency.*2
Display order setting of the measurement function	[--]	[Total]
Display on the screen	The "rms" indication is attached to the measurement function.	The "rms" indication is not attached to the measurement function.
Display example of the voltage measurement function of element 1	Urms1*1	U1

*1 When the number of displayed items is set to All, rms is not displayed. Distinguish between normal measured value and total value by checking the measurement mode display at the upper left of the screen.

Example in Which a Difference Occurs between the Normal Measured Value and Total Value.

For example, let's assume that a 10-kHz harmonic component is included in the inverter voltage signal with a fundamental frequency of 50 Hz. The total value that is determined by measuring this signal from 0th order (DC) to 100th order (5 kHz) does not contain rms components exceeding 5 kHz. Therefore, the value does not include the rms component of 10 kHz. In addition, if the voltage signal includes a 316-Hz (frequency that is 6.32 times the fundamental frequency) component, it is not included in the total value.*3 This is because the total value uses a computing method that takes the total of the rms components of each order in the specified range. On the other hand, the normal measured value is an rms value that includes the 10-kHz and 316-Hz components described above. Moreover, if the measurement bandwidth is limited by a line filter, both the total value and normal measured value do not include rms components that exceed the measurement bandwidth.

*2 In IEC harmonic measurement mode, rms components that are not an integer multiple of the fundamental signal may be included. For details, see chapter 9.

Likewise, the computing method of active power P, apparent power S, reactive power Q, power factor λ, and phase angle φ also varies by measurement mode, and the frequency components that are included differ.

- **Elements**

Element refers to a set of input terminals that can input a single phase of voltage and current to be measured. The WT3000 can contain up to four elements, which are numbered from 1 to 4. An element number is appended to the measurement function symbol for the measured data that the WT3000 displays, so that the correspondence between the numeric data and the element can be seen. For example, "U1(2)" represents the voltage of the 2nd order harmonic of element 1.

- **Wiring System**

You can specify five wiring systems--single-phase, two-wire; single-phase, three-wire; three-phase, three-wire; three-phase, four-wire; and three-phase, three-wire (three-voltage, three current)--on the WT3000 to measure the power of various single-phase and three-phase power transmission systems.

- **Wiring Unit**

A wiring unit refers to a set of two or three input elements of the same wiring system that are grouped. Depending on the wiring system pattern, up to two wiring units can be constructed, which are represented by symbols ΣA and ΣB . The measurement function of a wiring unit is called a Σ function.

For example, "USA(1)" represents the voltage average of the fundamental signal of the input elements that are assigned to wiring unit ΣA .

- **PLL Source «For procedures, see section 7.4»**

When measuring harmonics, the fundamental period (period of the fundamental signal) must be determined in order to analyze the higher orders. The PLL (Phase Locked Loop) source is the signal that is used to determine the fundamental period. Selecting a signal with little distortion or fluctuation for the PLL source results in a stable harmonic measurement. An ideal signal would be a rectangular wave with amplitude that is greater than or equal to 50% or 100% of the measurement range (see section 1.3) when the crest factor (see section 4.6 in the *User's Manual IM760301-01E*) is set to 3 or 6, respectively.

In addition, stable harmonic measurement can also be achieved by applying a clock signal (Ext Clk) that has the same period as the waveform on which to perform harmonic measurements.

For a description of the terminology such as fundamental signal, harmonic signal, and harmonic order, see appendix 4 in the *User's Manual IM760301-01E*.

Types of Harmonic Measurement Functions

The data (numeric data) of harmonic measurement functions is measured or computed from the sampled data* described later in “Measurement Period.”

* See the description of the sampled data in “Types of Measurement Functions during Normal Measurement” of chapter 2 in the *User’s Manual IM760301-01E*.

- **Types of Harmonic Measurement Functions**
 - **Harmonic Measurement Functions for Each Input Element**

The following 26 types of harmonic measurement functions are available. For details related to the determination of measurement function data, see section 7.11.

Measurement function		Characters or Numbers in Parentheses			Total (No ())
		dc	1	k	
Voltage	U()	Yes	Yes	Yes	Yes ⁻¹
Current	I()	Yes	Yes	Yes	Yes ⁻¹
Active power	P()	Yes	Yes	Yes	Yes ⁻¹
Apparent power	S()	Yes	Yes	Yes	Yes ⁻¹
Reactive power	Q()	Always 0	Yes	Yes	Yes ⁻¹
Power factor	λ()	Yes	Yes	Yes	Yes ⁻¹
Phase difference	φ()	No	Yes	Yes	Yes ⁻¹
Phase difference with respect to U(1)	φU()	No	No	Yes	No
Phase difference with respect to I(1)	φI()	No	No	Yes	No
Impedance of the load circuit	Z()	Yes ⁻²	Yes ⁻²	Yes ⁻²	No
Series resistance of the load circuit	Rs()	Yes ⁻²	Yes ⁻²	Yes ⁻²	No
Series reactance of the load circuit	Xs()	Yes ⁻²	Yes ⁻²	Yes ⁻²	No
Parallel resistance of the load circuit	Rp()	Yes ⁻²	Yes ⁻²	Yes ⁻²	No
Parallel reactance of the load circuit	Xp()	Yes ⁻²	Yes ⁻²	Yes ⁻²	No
Voltage harmonic distortion factor	Uhdf()	Yes	Yes	Yes	No
Current harmonic distortion factor	Ihdf()	Yes	Yes	Yes	No
Active power harmonic distortion factor	Phdf()	Yes	Yes	Yes	No
Total harmonic distortion of voltage	Uthd	No	No	No	Yes
Total harmonic distortion of current	Ithd	No	No	No	Yes
Total harmonic distortion of active power	Pthd	No	No	No	Yes
Voltage telephone harmonic factor	Uthf	No	No	No	Yes ⁻²
Current telephone harmonic factor	Ithf	No	No	No	Yes ⁻²
Voltage telephone influence factor	Utif	No	No	No	Yes ⁻²
Current telephone influence factor	Itif	No	No	No	Yes ⁻²
Harmonic voltage factor	hvf	No	No	No	Yes ⁻²
Harmonic current factor	hcf	No	No	No	Yes ⁻²

Yes: Numeric data available, No: No numeric data available

- The meaning of measurement functions with parentheses varies depending on the characters or numbers that are inside the parentheses as follows:
 - dc: Indicates numeric data of the DC component.
 - 1: Indicates numeric data of the fundamental wave.
 - k: Indicates numeric data from 2nd to Nth order harmonics. N is the upper limit of the measured order (see section 7.6). The upper limit is determined automatically (maximum is 100) by the frequency of the PLL source.
- Uhdf to hcf are measurement functions that indicate characteristics specific to the harmonics. For details on the determination of the measurement functions, see section 7.11.

*1 Cannot be measured with the harmonic measurement in normal measurement mode.

*2 Cannot be measured in IEC harmonic measurement mode.

- **Harmonic Measurement Function That Indicates the Phase Difference (ϕ) of the Voltage and Current between the Input Elements**

There are five harmonic measurement functions that express the phase difference (ϕ).

ϕU_i-U_j , ϕU_i-U_k , ϕU_i-I_i , ϕU_i-I_j , and ϕU_i-I_k

(where i , j , and k are input element numbers)

Explanation is given for the case when the number of installed input elements is 4, elements 1, 2, and 3 are assigned to wiring unit ΣA using a three-phase, four-wire system. Here $i = 1$, $j = 2$, and $k = 3$.

In this case, the numeric data of the harmonic measurement functions of phase difference concerning elements 1, 2, and 3 can be determined as shown below.

- $\phi U1-U2$

Phase difference of the fundamental voltage $U2(1)$ of element 2 with respect to the fundamental voltage $U1(1)$ of element 1.

- $\phi U1-U3$

Phase difference of the fundamental voltage $U3(1)$ of element 3 with respect to the fundamental voltage $U1(1)$ of element 1.

- $\phi U1-I1$

Phase difference of the fundamental current $I1(1)$ of element 1 with respect to the fundamental voltage $U1(1)$ of element 1.

- $\phi U1-I2$

Phase difference of the fundamental current $I2(1)$ of element 2 with respect to the fundamental voltage $U1(1)$ of element 1.

- $\phi U1-I3$

Phase difference of the fundamental current $I3(1)$ of element 3 with respect to the fundamental voltage $U1(1)$ of element 1.

If the wiring pattern is set up so that input elements 1 and 2 are assigned to wiring unit ΣA using a three-phase, three-wire system and input elements 3 and 4 are assigned to wiring unit ΣB using a three-phase, three-wire system, the numeric data below are determined.

- Wiring unit ΣA : $\phi U1-U2$, $\phi U1-I1$, and $\phi U1-I2$

- Wiring unit ΣB : $\phi U3-U4$, $\phi U3-I3$, and $\phi U3-I4$

$\phi U1-U3$ and $\phi U1-I3$ are not determined.

- **Harmonic Measurement Function of Wiring Units ΣA and ΣB (Σ Functions)**

The following 6 types of harmonic measurement functions are available. For details on the determination of each measurement function, see section 7.9.

Measurement function	Characters or Numbers in Parentheses
	1
$U\Sigma()$	Yes
$I\Sigma()$	Yes
$P\Sigma()$	Yes
$S\Sigma()$	Yes
$Q\Sigma()$	Yes
$\lambda\Sigma()$	Yes

Yes: Numeric data available

- For measurement functions with parentheses, the value "1" is entered in the parentheses. This represents the numeric data of the fundamental signal.

Measurement Period of Harmonic Measurement Functions

The measurement period is the first 9000 points from the beginning of the data update interval at the harmonic sampling frequency. The sampling frequency for harmonic measurement is automatically determined in the WT3000 from the period of the signal set as the PLL source. The sampled data and measurement period on which computation is based may be different from those of the measurement functions of normal measurement.

Numeric Displays for Harmonic Measurement

In addition to 4-item, 8-item, 16-item, and all-item displays, list display (single list and dual list) can be shown.

- **Selecting the Number of Displayed Items**

You can select 4, 8, 16, or All for the number of displayed items. Not all the data can be displayed on one screen. You can scroll through the displayed items to view the following data.

8-Item Display Example

Measurement function ↓	Urms1	105.677	v	Data ↓
	Irms1	569.556	ma	
	P1	55.7601	w	
	S1	60.1889	va	
	Q1	-22.6609	var	
	U1(1)	5.793	v	
	I1(1)	34.467	ma	
	P1(1)	0.1937	w	

- **List Display**

For each measurement function, the numeric data of the fundamental and all harmonics can be displayed in two columns. When the numeric data is displayed simultaneously with waveforms, bar graphs, or trends, approximately half of the data is displayed.

- **Single List**

The data of a single measurement function is displayed by separating the even and odd harmonics in each column. You can select the following measurement functions: U, I, P, S, Q, λ, φ, φU, φI, Z, Rs, Xs, Rp, and Xp.

Measurement function 1

change items

PLL U1

Freq 49.998 Hz

Urms1 107.504 V

Irms1 559.016mA

P1 55.6703 W

S1 60.0965 VA

Q1 -22.6366 var

λ1 0.92635

φ1 D 22.128 °

Uthd1 38.062 %

Ithd1 52.038 %

Pthd1 1.596 %

Uthf1 15.334 %

Ithf1 19.154 %

Uthf1 626.985

Ithf1 797.307

△PAGE 1/7

	Or.			dc		
	U1	I1	hdff[%]	U1	I1	hdff[%]
1	3.976	92.473	2	1.165	27.088	
3	0.549	12.757	4	0.444	10.331	
5	0.414	9.618	6	0.290	6.750	
7	0.259	6.035	8	0.225	5.230	
9	0.206	4.783	10	0.164	3.818	
11	0.400	9.297	12	0.143	3.322	
13	0.126	2.923	14	0.116	2.689	
15	0.123	2.854	16	0.105	2.434	
17	0.096	2.229	18	0.109	2.529	
19	0.080	1.871	20	0.088	2.044	
21	0.084	1.948	22	0.082	1.907	
23	0.081	1.874	24	0.066	1.542	
25	0.068	1.587	26	0.026	0.610	
27	0.060	1.403	28	0.062	1.436	
29	0.056	1.313	30	0.052	1.215	
31	0.054	1.260	32	0.053	1.226	
33	0.049	1.148	34	0.051	1.194	
35	0.047	1.089	36	0.048	1.116	
37	0.046	1.080	38	0.043	0.988	
39	0.043	1.003	40	0.042	0.970	

△PAGE 1/3

↓ Data related to all harmonics

↓ Data of each harmonic order

Numeric data of each harmonic order

Relative harmonic content of each harmonic (Uhdff, Ihdff, and Phdff are displayed when the selected measurement function are U, I, and P, respectively.)

Measurement function display

• **Dual List**

The data of two measurement functions is displayed in its own column. You can select the following measurement functions: U, I, P, S, Q, λ, φ, φU, φI, Z, Rs, Xs, Rp, and Xp.

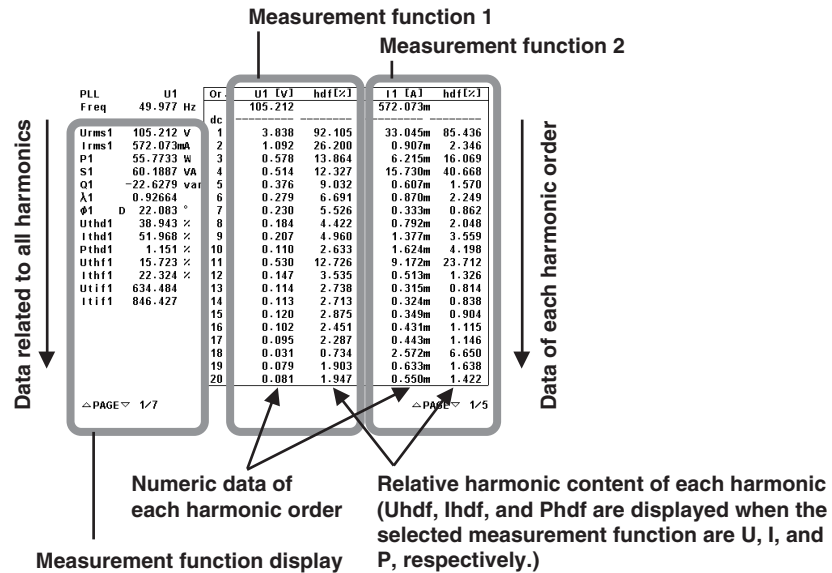

• **Scrolling the Page**

The numeric display screen can be switched at the page level. If different items are displayed on each page, the displayed items can be switched collectively.

• **Resetting the Numeric Display**

If the number of displayed items is 4, 8, or 16, the displayed order of measurement functions can be reset to factory default settings.

Equation for Distortion Factor «For procedures, see section 7.6.»

The measurement functions, U hdf, I hdf, P hdf, U thd, I thd, and P thd during harmonic measurement have two defining equations. For the equations, see section 7.9.

Bar Graph Display «For procedures, see section 7.7.»

The amplitude of each harmonic can be displayed on the bar graph. The horizontal axis represents harmonic order, and the vertical axis represents the amplitude of each harmonic. The harmonic measurement functions, elements, and order to be displayed can be specified. You can select the following harmonic measurement functions: U, I, P, S, Q, λ , ϕ , ϕU , ϕI , Z, Rs, Xs, Rp, and Xp. The screen can be divided into top and bottom halves so that the bar graph can be displayed simultaneously with the numeric data. Bar graphs cannot be displayed in IEC harmonic measurement mode.

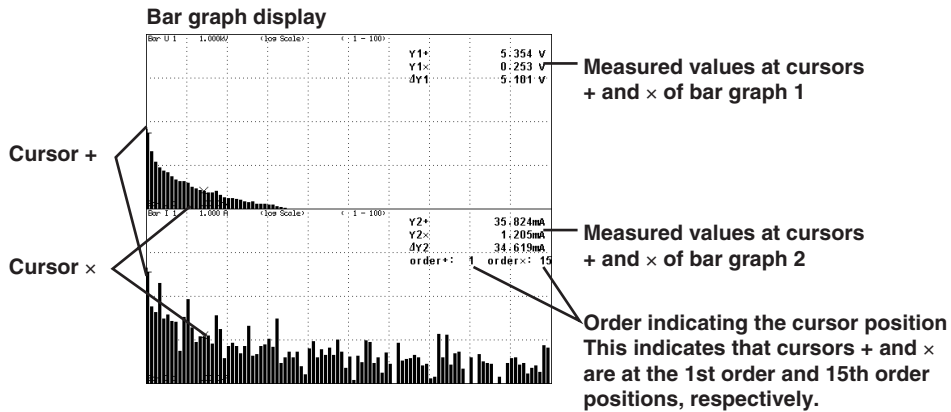

Vector Display «For procedures, see section 7.8.»

During harmonic measurement, vectors can be displayed to show the relationship between the phase difference and amplitude (rms value) of the fundamental signals U(1) and I(1) of each element that is assigned to the selected wiring unit. The positive vertical axis is set to 0 (angle 0), and the vector of each input signal is displayed. In addition, you can zoom in on the vector or display the values of the amplitude and the phase difference between the signals simultaneously.

The vector display is shown on the next page.

The elements that are to be displayed as vectors vary depending on the number of installed input elements and the selected wiring pattern.

Explanation is given for the case when the number of installed input elements is 4 and wiring unit ΣA is set to a three-phase, four-wire system.

When the target of the vector display is set to wiring unit ΣA, the target elements are 1, 2, and 3. Vectors 1, 2, and 3 correspond to elements 1, 2, and 3, respectively. The relationship between the phase difference and amplitude of U1(1), U2(1), U3(1), I1(1), I2(1), and I3(1) is displayed as vectors.

Vectors cannot be displayed in IEC harmonic measurement mode.

- **Vector Display When the Wiring System Is 3P4W (Three-Phase, Four-Wire)**
 $U_1(1)$, $U_2(1)$, and $U_3(1)$ are common mode voltages. $I_1(1)$, $I_2(1)$, and $I_3(1)$ are line currents.

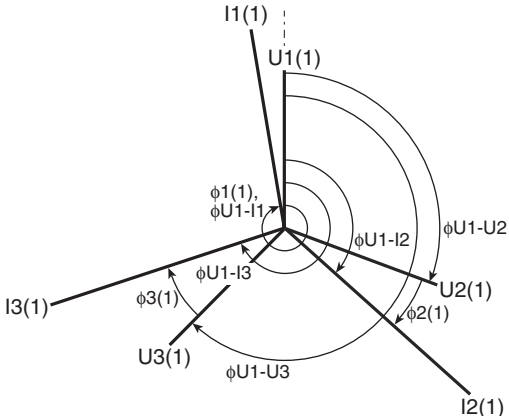

- **Vector Display When the Wiring System Is 3P3W (3V3A) (Three-Voltage, Three-Current)**
 $U_1(1)$, $U_2(1)$, and $U_3(1)$ are line voltages. $I_1(1)$, $I_2(1)$, and $I_3(1)$ are line currents.

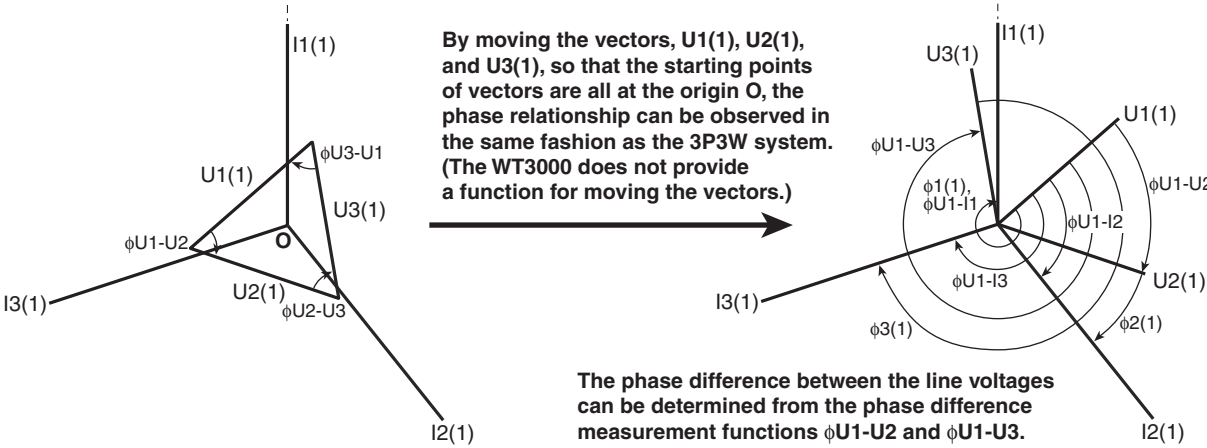

The phase difference between the line voltages can be determined from the phase difference measurement functions ϕ_{U1-U2} and ϕ_{U1-U3} .

ϕ_{U1-U2} = This is the measurement function ϕ_{U1-U2} .
 $\phi_{U2-U3} = (\phi_{U1-U3}) - (\phi_{U1-U2}) - 180^\circ$
 $\phi_{U3-U1} = -(\phi_{U1-U3})$

- **Vector Display When the Wiring System Is 3P3W (Three-Phase, Three-Wire)**
 $U_1(1)$, $U_2(1)$, and $U_3(1)$ are line voltages. $I_1(1)$, $I_2(1)$, and $I_3(1)$ are line currents. However, $U_3(1)$ and $I_3(1)$ are not actually measured for the 3P3W system. The vectors are displayed through computation.

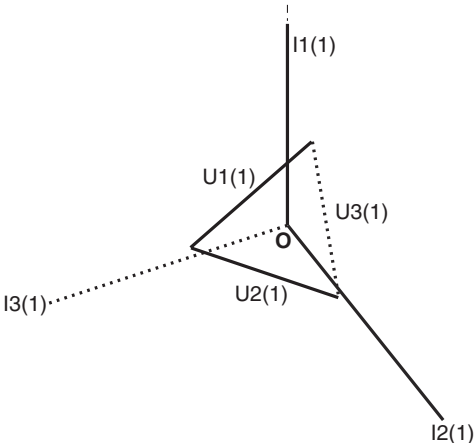

7.2 Setting the Measurement Mode and Displaying Numeric Data

Procedure

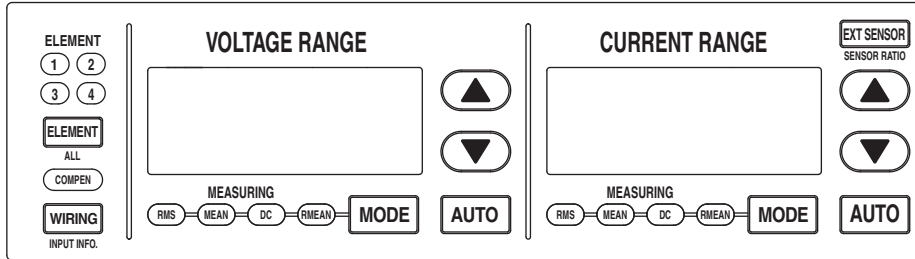

To exit the menu during operation, press **ESC** located above the soft keys.

In the procedural explanation below, the phrase “press the **cursor keys**” may be used. This phrase refers to the procedures for selecting items and entering values and character strings. For details on the procedures, see section 3.14 in the *User's Manual IM760301-01E*.

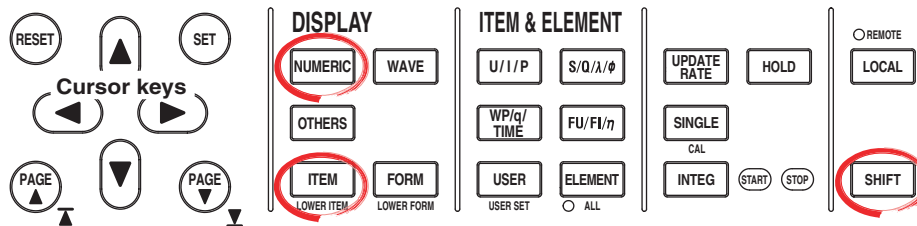

- **Displaying Numeric Data**

1. Press **NUMERIC** to display numeric data.

- **Displaying Numeric Data on the Split Display**

1. Press **OTHERS** to display the Others menu.
2. Press any of the soft keys from **Numeric+Wave**, **Numeric+Bar**, and **Numeric+Trend** to select the display mode.

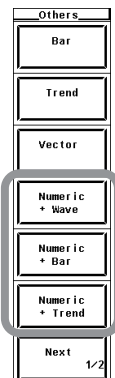

- **Enabling Normal Measurement Mode**

If wide bandwidth harmonic measurement mode is enabled on models with the advanced computation (/G6) option, switch to normal measurement mode.

2. Press **HRM SET** to display the Harmonics menu.
3. Press the **Freq Band** soft key to select Normal.

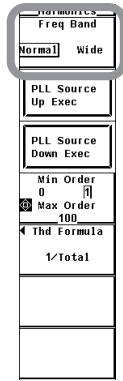

Explanation

• **Meaning of the Measurement Function Symbols**

For the meanings of the measurement function symbols that are displayed, see section 7.1, “Harmonic Measurement Function” or 7.11, “Harmonic Measurement Specifications.”

Example 20th harmonic voltage of element 2

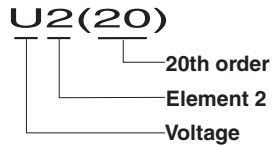

Average of the Fundamental Current of the Elements Combined by Wiring Unit ΣB

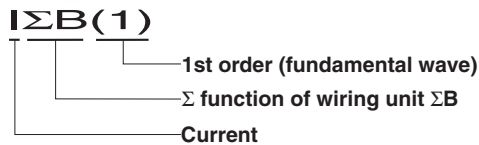

• **Selecting the Display Mode**

Select the display format of the numeric data from below. [-----] (no data) is displayed in places where the measurement function is not selected or there are no numeric data.

• **Displaying the Numeric Data on the Entire Screen**

Press the NUMERIC key to display the numeric data on the entire screen.

• **Displaying Numeric Data by Dividing the Screen into Halves (Split Display)**

• **Numeric+Wave**

The numeric data and waveform are displayed separately in the top and bottom windows.

• **Numeric+Bar**

The numeric data and bar graph are displayed separately in the top and bottom windows. For details on how to set the bar graph display, see section 7.9.

• **Numeric+Trend**

The numeric data and trend are displayed separately in the top and bottom windows.

7.3 Setting the Number of Displayed Items, Page Scrolling the Display

Procedure

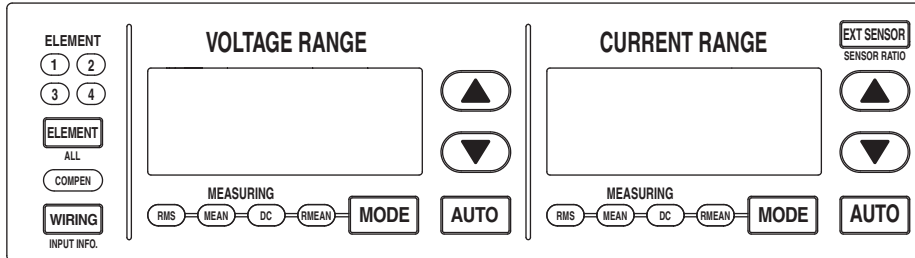

To exit the menu during operation, press **ESC** located above the soft keys.

In the procedural explanation below, the phrase “press the **cursor keys**” may be used. This phrase refers to the procedures for selecting items and entering values and character strings. For details on the procedures, see section 3.14 in the *User's Manual IM760301-01E*.

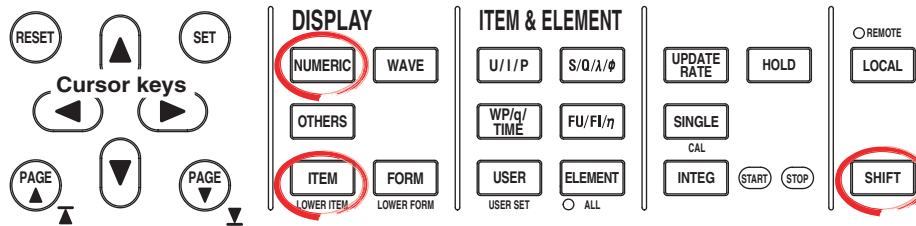

- **Selecting the Number of Displayed Items or List Display**

1. Press **FORM** to display the Numeric Form menu.
2. Select one of the soft keys from **4 Items** to **Dual List** to select the number of displayed items or list display.



- **Page Scrolling the Display (PAGE ▼ ▲ key)**

- **When Numeric Form (the Number of Displayed Items) Is 4 Items, 8 Items, or 16 Items**

3. Press **PAGE ▼** or **PAGE ▲** to scroll the page.
 - Press **PAGE ▼** to display the next page.
 - Press **PAGE ▲** to display the previous page.

- **When Numeric Form (the Number of Displayed Items) Is ALL Items**

3. Press **PAGE ▼** or **PAGE ▲** to scroll the page.
 - The first page is always displayed in the top half of the screen.
 - Press **PAGE ▼** to display the next page in the lower half of the screen.
 - Press **PAGE ▲** to display the previous page in the lower half of the screen.
 - * If numeric data is displayed on the split display, pages 1 to 9 are scrolled in the top half of the screen.

- **When Numeric Form (the Number of Displayed Items) Is Single List or Dual List**
 3. Press **ESC** to clear the soft menu.
 4. Press the **cursor keys (left and right keys)** to move the cursor to the left, center, or right column of the screen.
 5. Press **PAGE ▼** or **PAGE ▲** to scroll the page.
 - The left and right columns can be scrolled independently.
 - If the cursor is in the left column on the screen, the measurement function display is page scrolled.
 - If the cursor is in the center or left column on the screen, the data display of harmonic orders is page scrolled.
- **Page Scrolling the Display (Cursor Keys)**
 - **When Numeric Form (the Number of Displayed Items) Is 4 Items, 8 Items, or 16 Items**
 - Press the cursor keys (up and down keys) to move the highlight within the page. To switch to the next page or previous page, press **PAGE ▼** or **PAGE ▲**.
 - **When Numeric Form (the Number of Displayed Items) Is ALL Items, Single List, or Dual List**
 3. Press the **cursor keys (up and down keys)**. The highlight moves.
 - If you press the down cursor key when the highlight is at the bottom row, the next page is displayed.
 - If you press the up cursor key when the highlight is at the top row, the previous page is displayed.
- **Jumping to the Last or First Page**
 3. Press **SHIFT+PAGE ▼ (▼)** or **SHIFT+PAGE ▲ (▲)**.
 - Press **SHIFT+PAGE ▼ (▼)** to display the last page.
 - Press **SHIFT+PAGE ▲ (▲)** to display the first page.

Explanation

- **Selecting the Number of Displayed Items or List Display**

Select the number of numeric data items that are displayed simultaneously or list display from the choices below.

 - **4 Items**
 - When the display mode is Numeric, four numeric data values are displayed in one column.
 - **8 Items**
 - When the display mode is Numeric, eight numeric data values are displayed in one column.
 - When the display mode is not Numeric, eight numeric data values are displayed in two columns.
 - **16 Items**
 - When the display mode is Numeric, 16 numeric data values are displayed in two columns.
 - **All Items**
 - A table is displayed indicating the numeric data of items with measurement functions listed vertically and symbols indicating elements and wiring units listed horizontally. The number of displayed items varies depending on the number of installed elements.

7.3 Setting the Number of Displayed Items, Page Scrolling the Display

- **Single List**
 - When the display mode is Numeric, 42 numeric data values for a single measurement function are displayed in two columns.
 - When the display mode is not Numeric, 22 numeric data values for a single measurement function are displayed in two columns.
- **Dual List**
 - When the display mode is Numeric, 22 numeric data values each for two measurement functions are displayed in each column.
 - When the display mode is not Numeric, 11 numeric data values each for two measurement functions are displayed in each column.

Note

- The order can be displayed from normal measured value (---) or from dc (0th order) up to 100th order. However, the numeric data up to the upper limit of measured order (see section 7.11) that is automatically determined by the frequency of the PLL source is the data determined by the harmonic measurement.
- [-----] (no data) is displayed in places where the measurement function is not selected or where no numeric data is present.
- If the analysis window width (number of cycles of the fundamental signal) that is determined by the fundamental frequency is shorter in time than the data update rate, harmonic data is not measured, and [-----] (no data) is displayed.
- If this happens, decrease the data update rate. For example, if the fundamental frequency is 50 Hz (20-ms cycle), the analysis window width is 10 waves (see section 7.11), and the data measurement interval is 200 ms. The time it takes to measure the harmonics in this case is greater than approximately 300 ms (data measurement interval + data processing time). To measure and display harmonic data, set the data update rate to a value greater than or equal to 500 ms.
- There are no overrange display [-OL-] and zero display (zero suppression) for the harmonic numeric data from dc (0th order) to the 100th order. For details on the overrange display and zero display (zero suppression) of normal measured values (order: ---), see section 5.1 in the *User's Manual IM760301-01E*.
- If the power factor λ is greater than 1 and less than or equal to 2, λ becomes [1]. ϕ displays zero.
- If the power factor λ is greater than 2, λ and ϕ display errors.

- **Page Scrolling the Display**
 - **When displaying 4, 8, or 16 items**

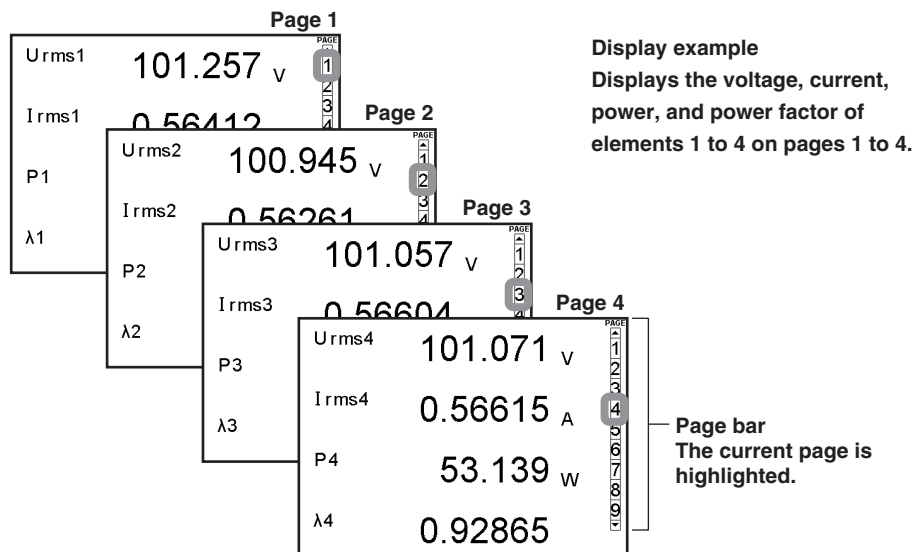

7.3 Setting the Number of Displayed Items, Page Scrolling the Display

- **When ALL is selected**

The first page is constantly displayed in the upper half of the screen, and page 2 and subsequent pages are switched in the lower half.

	Element1	Element2	Element3	Element4
Voltage	100Vrms	100Vrms	100Vrms	100Vrms
Current	500mA rms	500mA rms	500mA rms	500mA rms
U [V]	105.715	105.746	105.620	0.000
I [A]	569.215m	565.763m	0.000m	1.592m
P [W]	55.8692	55.5459	0.0000	-0.0000
S [VA]	60.1748	59.8274	0.0000	0.0000
Q [var]	-22.3526	-22.2255	0.0000	0.0000
λ []	0.92845	0.92844	-----	Error
φ [°]	21.806	21.808	-----	Error
fU [Hz]	50.000	50.000	50.000	Error
fI [Hz]	1.7288k	1.9361k	Error	Error
U+pk[V]	148.617	148.676	148.509	0.119
U-pk[V]	-148.622	-148.669	-148.506	-0.104
I+pk[A]	1.04405	1.04036	0.000m	6.537m
I-pk[A]	-1.04668	-1.04046	0.000m	-5.616m
CIU []	1.406	1.406	1.406	Error
CI I []	1.839	1.839	-----	4.105
Pc [W]	55.9683	55.6440	0.0000	Error

The first page is always displayed.

Page 2 and subsequent pages are displayed by page scrolling.

* If ALL display is shown on the split screen, pages 1 to 9 are scrolled in the top half of the screen.

- **When Single List or Dual List is selected**

The measurement function display (left side of the screen) and the harmonic order data display (right side of the screen) can be page scrolled independently.

Single List Display Example

change items		Or.		U1 [V]		hdf [%]		Or.		U1 [V]		hdf [%]	
PLL	U1												
Freq	49.998 Hz			107.504				dc					
Urms1	107.504 V	1	3.976	92.473	2	1.165	27.088						
Irms1	559.016mA	3	0.549	12.757	4	0.444	10.331						
P1	55.6703 W	5	0.414	9.618	6	0.290	6.750						
S1	60.0965 VA	7	0.259	6.035	8	0.225	5.230						
Q1	-22.6366 var	9	0.206	4.783	10	0.164	3.818						
λ1	0.92635	11	0.400	9.297	12	0.143	3.322						
φ1	D 22.128 °	13	0.126	2.923	14	0.116	2.689						
Uthd1	38.062 %	15	0.123	2.854	16	0.105	2.434						
Ithd1	52.038 %	17	0.096	2.229	18	0.109	2.529						
Pthd1	1.596 %	19	0.080	1.871	20	0.088	2.044						
Uthf1	15.334 %	21	0.084	1.940	22	0.082	1.907						
Ithf1	19.154 %	23	0.081	1.874	24	0.086	1.542						
Uthf1	626.985	25	0.068	1.567	26	0.026	0.810						
Ithf1	797.307	27	0.060	1.403	28	0.062	1.436						
		29	0.056	1.313	30	0.052	1.215						
		31	0.054	1.260	32	0.053	1.226						
		33	0.049	1.148	34	0.051	1.194						
		35	0.047	1.089	36	0.048	1.118						
		37	0.046	1.080	38	0.043	0.988						
		39	0.043	1.003	40	0.042	0.970						

~PAGE 1/7

Measurement function display

Page information on the measurement function display

▲PAGE 1/3

Page information on the harmonic order data display

Harmonic order data display

7.4 Changing the Displayed Items of Numeric Data

Procedure

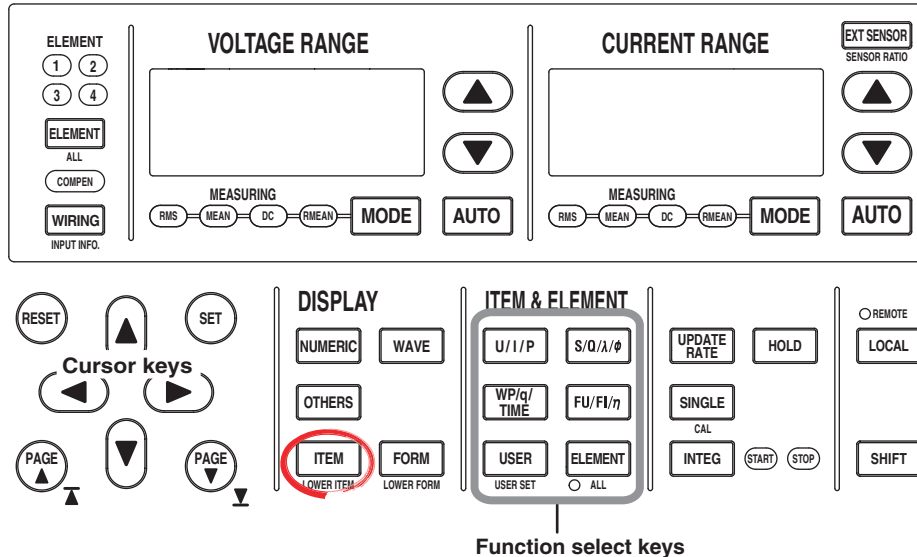

To exit the menu during operation, press **ESC** located above the soft keys.

In the procedural explanation below, the phrase “press the **cursor keys**” may be used. This phrase refers to the procedures for selecting items and entering values and character strings. For details on the procedures, see section 3.14 in the *User's Manual IM760301-01E*.

- Check that display mode is set to Numeric, Numeric+Wave, or Numeric+Trend. For details on how to set the display mode, see section 7.1.
- The following procedures are given as typical examples in which the display mode is set to Numeric.

There are four ways to change the displayed items of numeric data. For the procedures of each method, see the pages indicated below.

- Selecting the displayed items using the function select key
 - Using the preset key See page 7-16.
 - Using the USER key See page 7-17.
 - Selecting the displayed items from the menu See page 7-18.
 - Selecting the harmonic order on the ALL display See page 7-19.
 - Resetting the order of the displayed items See page 7-19.

Changing the Displayed Items Using the Function Select Key

• Using the Preset Key

The display of measurement functions of U, I, P, S, Q, λ , ϕ , WP, q, TIME, FU, FI, and η and the element/wiring unit can be changed using function select keys.

• Selecting the Item to Be Changed

1. Press **ESC** to clear the Numeric Form menu.
2. Press the **cursor keys** to select the item to be changed. The item to be changed is highlighted.
 - If the display mode is set to Single List or Dual List, move the cursor to the center or the right side of the screen.

- **Changing the Measurement Function**
 3. Press the **U/I/P**, **S/Q/λ/φ**, **WP/q/Time**, or **FU/FI/η** function select key to select the displayed measurement function.

When the display mode is set to Single List or Dual List, only the measurement functions that contain harmonic order data can be selected. Press U/I/P to select U, I, or P. Press S/Q/λ/φ to select S, Q, λ, φ, φU, or φI.

- **Changing the Element/Wiring Unit**
 4. Press **ELEMENT** to select the element/wiring unit.

- **Changing the Element/Wiring Unit Collectively**
 5. Press **SHIFT+ELEMENT (ALL)**. ALL LED illuminates, and the element/wiring unit of all the displayed items on the displayed page can be changed collectively. This completes the procedure for changing the displayed items using the function select keys.

- **Using the USER Key**

By assigning measurement functions to the USER key, up to four measurement functions can be directly displayed.

 - **Assigning Measurement Functions to the USER Key**
 6. Press **SHIFT+USER (USER SET)** to display the User Reserved menu.
 7. Press any of the soft keys from **Function 1 to 4** to select the desired Function. The measurement function selection box appears.
 8. Press the **cursor keys** to select any of the measurement functions starting with None.
 9. Press **SET**. The symbol for the selected measurement function is displayed at the highlighted position.

 - **Changing the Measurement Function with the USER Key**
 10. Press **USER** to select the measurement function in the same fashion as step 3.

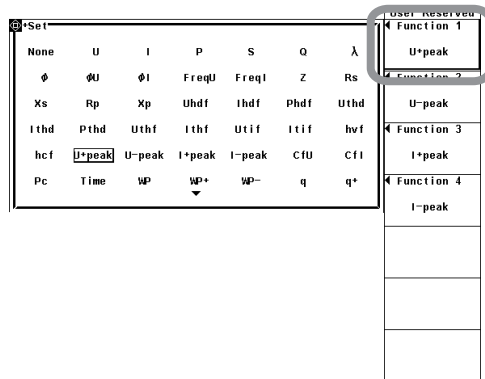

7.4 Changing the Displayed Items of Numeric Data

Selecting the Displayed Items from the Menu

1. Press **ITEM** to display the Numeric menu.

- **Selecting the Item to Be Changed**

2. Press the **Item No.** soft key.
3. Press the **cursor keys** to select the item to be changed. The item to be changed is highlighted.

- **Changing the Measurement Function**

4. Press the **Function** soft key to display the measurement function selection box.
5. Press the **cursor keys** to select any of the measurement functions starting with None.
6. Press **SET**. The symbol for the selected measurement function and the numeric data are displayed at the highlighted position.
 - When the display mode is set to Single List or Dual List, only the measurement functions that contain harmonic order data can be selected. (U, I, P, S, Q, λ , ϕ , ϕU , ϕI , Z, Rs, Xs, Rp, and Xp)

- **Changing the Element/Wiring Unit**

7. Press the **Element/ Σ** soft key to display the element/wiring unit selection box.
8. Press the **cursor keys** to select any of the elements/wiring units starting with Element1.
9. Press **SET**. The symbol for the selected element number or wiring unit and the numeric data are displayed at the highlighted position.

- **Changing the Order**

10. Press **Order** soft key.
11. Press the **cursor keys** to set the order. The specified harmonic order and the numeric data are displayed at the highlighted position. This completes the procedure for changing the displayed items using the menu.
 - When the display mode is set to Single List or Dual List, you do not have to set the order.

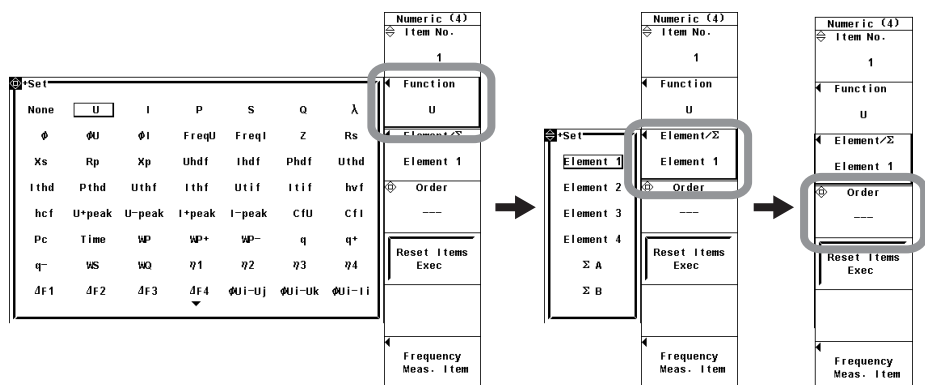

Selecting the Harmonic Order on the ALL Display

1. Press **PAGE** ▼ ▲ to display the harmonic order data page (page 6 or page 7).
2. Press **FORM** to display the Numeric Form menu.
3. Press the **cursor keys** to set the order.

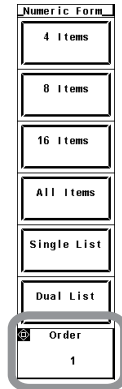
**Resetting the Order of the Displayed Items**

1. Press **ITEM** to display the Numeric menu.
2. Press the **Reset Items Exec** soft key. An Alert dialog box appears.
3. Press the **cursor keys** to select OK.
4. Press **SET**.

The order of the displayed items of all pages is reset.
To not reset, select Cancel and press **SET**.

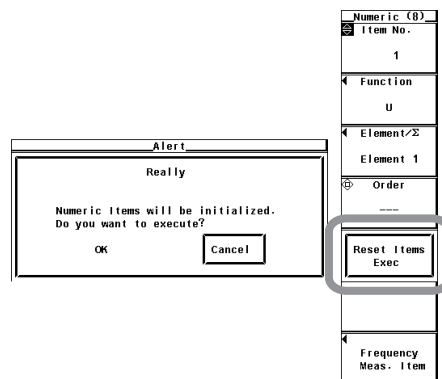

7.4 Changing the Displayed Items of Numeric Data

Explanation

The following limitations on changing the displayed items exist depending on Item Amount (the number of displayed items).

Number of Displayed Items		Changing the Displayed Items
4 Items, 8 Items, 16 Items		Yes
ALL Items		The displayed item cannot be changed independently. Switch the display using the cursor keys or by page scrolling. The order can be selected on the harmonic data display on six or seven pages.
Single List or Dual List	Measurement function display (left side of the screen)	The displayed item cannot be changed independently. Switch the display using the cursor keys or by page scrolling.
	Harmonic order data display (right side of the screen)	Only the measurement functions that contain harmonic order data can be selected. (U, I, P, S, Q, λ , ϕ , ϕU , ϕI , Z, Rs, Xs, Rp, and Xp)

- **When Numeric Form (the Number of Displayed Items) Is 4 Items, 8 Items, or 16 Items**

- **Changing the Measurement Function**

- The selectable measurement functions are the items indicated in section 7.1, "Harmonic Measurement Function."
 - You can also select not to display the measurement functions (None).

- **Changing the Element/Wiring Unit**

You can select the element/wiring unit from the choices below. The selectable items vary depending on the installed elements.

Element1, Element2, Element3, Element4, SA, and SB

- **Changing the Order**

When the measurement mode is set to normal measurement, waveform computation, or FFT, the measured order can be set to normal measured value (---) or from dc (0th order) up to 100th order.

When the measurement mode is set to wide bandwidth harmonic measurement mode, the measured order can be set to total value or from dc (0th order) up to 100th order.

U1(1)	4.219 _v		U1(1)	5.745 _v
I1(1)	31.921 _{mA}	Change the measurement function of the third item →	I1(1)	36.790 _{mA}
P1(1)	0.1346 _w		Φ1(1)	-20.322 _·
S1(1)	0.1347 _{VA}	Change the element of the third item ↘	S1(1)	0.2113 _{VA}
			U1(1)	7.973 _v
			I1(1)	29.771 _{mA}
			P2(1)	0.2358 _w
			S1(1)	0.2374 _{VA}
			↓ Change the order	
			U1(1)	5.836 _v
			I1(1)	34.188 _{mA}
			P2(7)	0.0009 _w
			S1(1)	0.1995 _{VA}

- **When Numeric Form (the Number of Displayed Items) Is Single List or Dual List**
Two types of lists are available for displaying the harmonic order data. When set to Single List, the data of List Item No. 1 is displayed using two columns. When set to Dual List, the data of List Item No. 1 and 2 is displayed in each column. You can set the list item No. to 1 or 2.

- **Changing the Measurement Function**

Select the measurement function to be changed from the choices below.

U, I, P, S, Q, λ , ϕ , ϕU , ϕI , Z, Rs, Xs, Rp, and Xp

- **Changing the Element/Wiring Unit**

The description is the same as “When Numeric Form (the Number of Displayed Items) Is 4 Items, 8 Items, or 16 Items” on the previous page.

Single List Display Example

PLL	U1	Or.	U1 [V]	hd [E]	I1 [A]	hd [E]
Freq	49.977 Hz		105.212		572.073m	
Urms1	105.212 V	1	3.838	92.105	33.045m	85.436
Irms1	572.073mA	2	1.092	26.200	0.907m	2.346
P1	55.7733 W	3	0.578	13.864	6.215m	16.069
S1	60.4087 V	4	0.514	12.327	15.730m	40.668
Q1	-22.6279 v	5	0.376	9.032	0.607m	1.570
λ 1	0.92664	6	0.279	6.691	0.070m	2.249
ϕ 1	D 22.083 °	7	0.230	5.526	0.333m	0.862
Uthd1	38.943 %	8	0.184	4.422	0.792m	2.048
Ithd1	51.968 %	9	0.207	4.960	1.377m	3.559
Pthd1	1.151 %	10	0.110	2.633	1.624m	4.198
Uthf1	15.723 %	11	0.530	12.726	9.172m	23.712
Ithf1	22.324 %	12	0.147	3.535	0.513m	1.326
Uthi1	634.484	13	0.114	2.738	0.315m	0.814
Ithi1	846.427	14	0.113	2.713	0.324m	0.838
		15	0.120	2.875	0.345m	0.904
		16	0.102	2.451	0.431m	1.115
		17	0.095	2.287	0.443m	1.146
		18	0.031	0.734	2.572m	6.650
		19	0.079	1.903	0.633m	1.638
		20	0.081	1.947	0.550m	1.422

Harmonic order data display
Measurement function display

- **Selecting the Order on the ALL Display**

The order can be selected on page 6 or 7 of the ALL display.

Order	Element1	Element2	Element3	Element4
k = 1	100Vrms	100Vrms	100Vrms	100Vrms
Voltage	100Vrms	100Vrms	100Vrms	100Vrms
Current	500mA rms	500mA rms	500mA rms	500mA rms
U [V]	106.336	106.367	106.240	0.000
I [A]	565.720m	562.282m	0.000m	1.614m
P [W]	55.8231	55.5008	0.0000	-0.0000
S [VA]	60.1563	59.8084	0.0000	0.0000
Q [var]	-22.4181	-22.2869	0.0000	0.0000
λ []	0.92797	0.92798	-----	Error
ϕ [°]	D 21.880	D 21.878	-----	Error
ϕU [°]	49.995	49.995	-----	Error
ϕI [°]	1.5035k	1.6573k	Error	Error
U(k) [V]	3.463	3.464	3.460	0.001
I(k) [A]	32.380m	32.154m	0.000m	0.022m
P(k) [W]	0.1112	0.1104	0.0000	0.0000
S(k) [VA]	0.1121	0.1114	0.0000	0.0000
Q(k) [var]	-0.0145	-0.0145	0.0000	0.0000
$\lambda(k)$ []	0.99163	0.99143	Error	0.69764
$\phi(k)$ [°]	-7.419	-7.504	Error	45.762

Measured data of the selected order
Select the order using the cursor keys

Note

- For the meanings of the measurement function symbols that are displayed, see section 7.1, “Harmonic Measurement Function” or 7.9, “Harmonic Measurement Specifications.”
- [-----] (no data) is displayed in places where the measurement function is not selected or where no numeric data is present.
- The range of the order of the numeric data determined by the harmonic measurement is from the minimum measured order specified in section 7.5 up to the upper limit of the measured order that is automatically determined by the PLL source frequency (see section 7.9). There is no numeric data for orders of numeric data of display items outside this range even if you specify such orders.

7.5 Selecting the PLL Source

Procedure

Cursor keys

RESET ▲ SET

◀ ▶

PAGE ▲ ▼ PAGE ▼

SCALING LINE FILTER AVG

MOTOR FREQ FILTER

HRM SET MEASURE SYNC SOURCE

CURSOR ○ NULL

FILE IMAGE SAVE STORE

MENU MENU STORE SET

PRINT MISC HELP

MENU

DISPLAY

NUMERIC WAVE

OTHERS

ITEM FORM

LOWER ITEM LOWER FORM

ITEM & ELEMENT

U/I/P S/Q/λ/φ

WP/q/TIME FU/FI/η

USER ELEMENT

USER SET ○ ALL

UPDATE RATE HOLD

SINGLE

CAL

INTEG START STOP

○ REMOTE

LOCAL

SHIFT

To exit the menu during operation, press **ESC** located above the soft keys.

In the procedural explanation below, the phrase “press the **cursor keys**” may be used. This phrase refers to the procedures for selecting items and entering values and character strings. For details on the procedures, see section 3.14 in the *User's Manual IM760301-01E*.

1. Press **HRM SET** to display the Harmonics menu.
2. Press the **PLL Source Up Exec** or the **PLL Source Down Exec** soft key to select the PLL source. The selected PLL source is displayed in the upper right corner of the screen at PLL Source.
 - Press the PLL Source Down Exec soft key to switch the selected PLL source as follows: U1 → I1 → U2 → I2 and so on.
 - Press the PLL Source Up Exec soft key to switch the selected PLL source as follows: I2 → U2 → I1 → U1 and so on.

Normal measurement mode	Wide bandwidth harmonic measurement mode	IEC harmonic measurement mode
<p>Harmonics</p> <p>Freq Band</p> <p>Normal Wide</p> <p>PLL Source Up Exec</p> <p>PLL Source Down Exec</p> <p>sin Order 0 [1]</p> <p>Max Order 100</p> <p>Thd Formula</p> <p>1/Total</p>	<p>Harmonics</p> <p>Freq Band</p> <p>Normal Wide</p> <p>PLL Source Up Exec</p> <p>PLL Source Down Exec</p> <p>sin Order 0 [1]</p> <p>Max Order 100</p> <p>Thd Formula</p> <p>1/Total</p> <p>PLL Input Warning Msg OFF [ON]</p>	<p>IEC Harmonics</p> <p>Object</p> <p>Element 1</p> <p>PLL Source Up Exec</p> <p>PLL Source Down Exec</p> <p>sin Order 0 [1]</p> <p>Max Order 100</p> <p>Thd Formula</p> <p>1/Total</p> <p>U Grouping OFF</p> <p>I Grouping OFF</p>

Explanation

For functional details, see section 7.1.

Set the PLL (Phase Locked Loop) source that is used to determine the fundamental period, which acts as the reference in the analysis of the harmonic orders.

- **Displayed Position of the Selected PLL Source**

The selected PLL source is displayed in the upper right corner of the screen when HRM SET is pressed.

Below is a display example when the PLL source is set to the voltage of Element1.

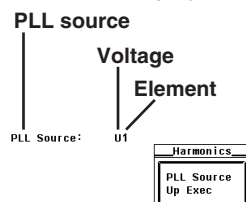

- **Selecting the PLL Source**

Select the PLL source from the choices below. The selectable items vary depending on the installed elements.

U1, I1, U2, I2, U3, I3, U4, I4, Ext Clk^{*1}, and Smp Clk^{*2}

*1 If you select "Ext Clk," harmonic measurement is performed using the frequency of the signal applied to the external clock input connector as the fundamental frequency.

*2 Selectable in wide bandwidth harmonic measurement mode on models with the advanced computation (/G6) option. If you select "Smp Clk," harmonic measurement is performed using 1/3000th of the frequency of the signal applied to the external clock input connector as the fundamental frequency.

- **When the PLL Source Is Set to Ext Clk or Smp Clk**

Apply a clock signal to the external clock input connector (EXT CLK) on the rear panel according to the following specifications.



- **Ext Clk Specifications**

Item	Specifications
Connector type	BNC connector
Frequency range	Harmonic measurement (/G5) option: 10 Hz to 440 Hz Advanced computation (/G6) option: 10 Hz to 2600 Hz
Input level	TTL
Input waveform	50% duty ratio rectangular wave

- **Smp Clk Specifications (Selectable in Wide Bandwidth Harmonic Measurement Mode)**

Item	Specifications
Connector type	BNC connector
Frequency range	Frequency equal to 3000 times the fundamental frequency of 0.1 Hz to 66 Hz
Input level	TTL
Input waveform	50% duty ratio rectangular wave



CAUTION

Applying a voltage outside the range of 0 to 5 V to the external clock input connector (EXT CLK) can damage the instrument.

Note

- Select a signal that has the same period as the target signal for the harmonic measurement. Selecting an input signal with little distortion for the PLL source enables stable harmonic measurement. If the fundamental frequency of the PLL source fluctuates or if the fundamental frequency cannot be measured due to waveform distortion, correct measurement results will not be obtained. If the distortion of the voltage signal is smaller than that of the current signal such as when the measured item is a switching power supply, it is recommended that the PLL source be set to the voltage.
If all the input signals are distorted or the amplitude level is small with respect to the measurement range, the specifications may not be met. To achieve accurate measurements on the high orders of the harmonics, set the PLL source to external clock and apply a signal with the same period as the input signal to the external clock input connector.
 - If the fundamental frequency is less than or equal to 440 Hz and the signal contains high frequency components, it is recommended that the frequency filter be turned ON. This filter is effective only on the frequency measurement circuit.
 - If the amplitude level of the signal input to the element specified as the PLL source is small with respect to the range, PLL synchronization may not be achieved. If the crest factor is set to 3, set the measurement range so that the amplitude level of the PLL source is at least 50%. If the crest factor is set to 6, set the measurement range so that the amplitude level of the PLL source is at least 100%.
 - If the frequency of the PLL source changes, correct measured values are displayed from the 4th data update after the change. Correct measured values may not be obtained immediately after the frequency of the PLL source changes or after changing the PLL source, because the PLL circuit inside the WT3000 redetects the frequency.
 - If you set the PLL source to Smp Clk in wide bandwidth harmonic measurement mode and change the measurement mode to normal measurement, the PLL source is set to Ext Clk.
-

7.6 Setting the Measured Order

Procedure

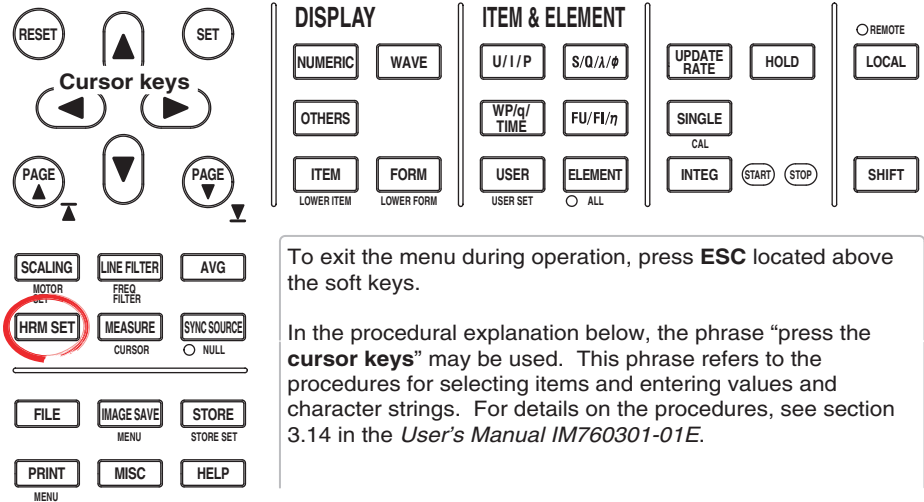

1. Press **HRM SET** to display the Harmonics menu.
- **Selecting the Minimum Harmonic Order to Be Measured**
 2. Press the **Min Order** soft key to select 0 or 1.
 - **Selecting the Maximum Harmonic Order to Be Measured**
 3. Press the **cursor keys** to set the maximum harmonic order to be measured.

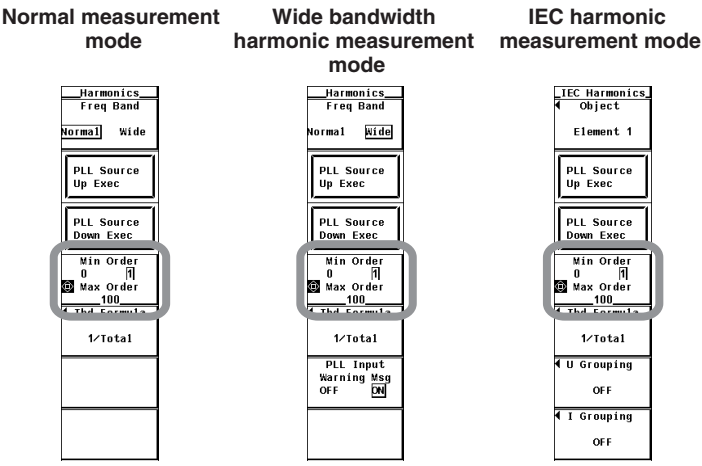

Explanation

The harmonic measurement range can be specified. The harmonic orders specified here are used to determine the numeric data of the distortion factor. For details on how to determine the distortion factor, see section 7.11.

- **Selecting the Minimum Harmonic Order to Be Measured**

The order can be selected from the following:

- 0: Includes the 0th order (DC) component when determining various numeric data of the harmonic waveform.
- 1: Does not include the 0th order (DC) component when determining various numeric data of the harmonic waveform. 1st order (fundamental signal) is the first component used.

- **Setting the Maximum Harmonic Order to Be Measured**

Select the harmonic order in the range from 1 to 100th order.

Note

- If the minimum harmonic order to be measured is set to 1, the data of the DC component is not included when determining the numeric data of distortion factor.
 - You can set the maximum harmonic order up to 100th order, but the maximum harmonic order that is actually used to determine the numeric data is the order corresponding to the upper limit of the measured order. The upper limit is determined automatically (maximum is 100th) by the frequency of the PLL source. The numeric data corresponding harmonic orders exceeding the upper limit are shown as [-----] (no data).
 - The maximum order that can be measured in IEC harmonic measurement mode is 50. Orders exceeding 50 cannot be measured even if you specify such orders.
 - If you use the Harmonic/Flicker Measurement Software, the maximum order is automatically set to 40.
-

7.7 Selecting the Distortion Factor Equation

Procedure

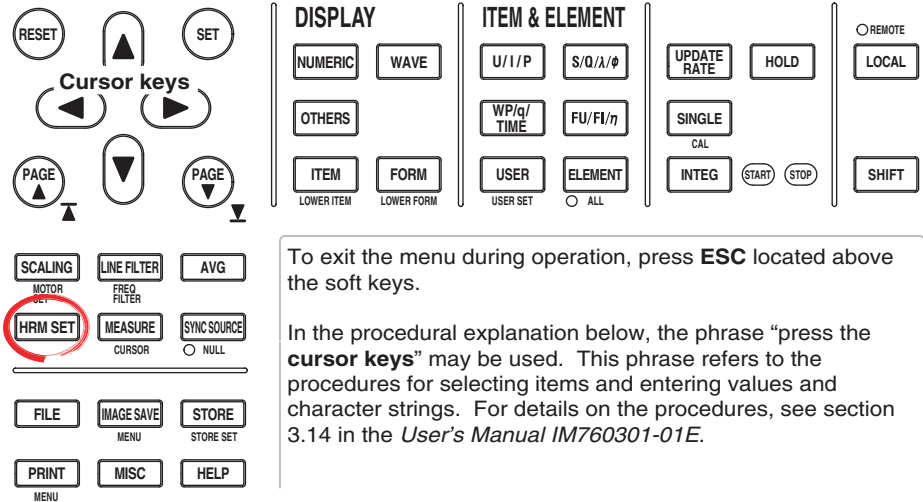

1. Press **HRM SET** to display the Harmonics menu.
2. Press the **Thd Formula** soft key to display the Thd Formula menu.
3. Press the **1/Total** or **1/Fundamental** soft key to select the equation for the distortion factor.

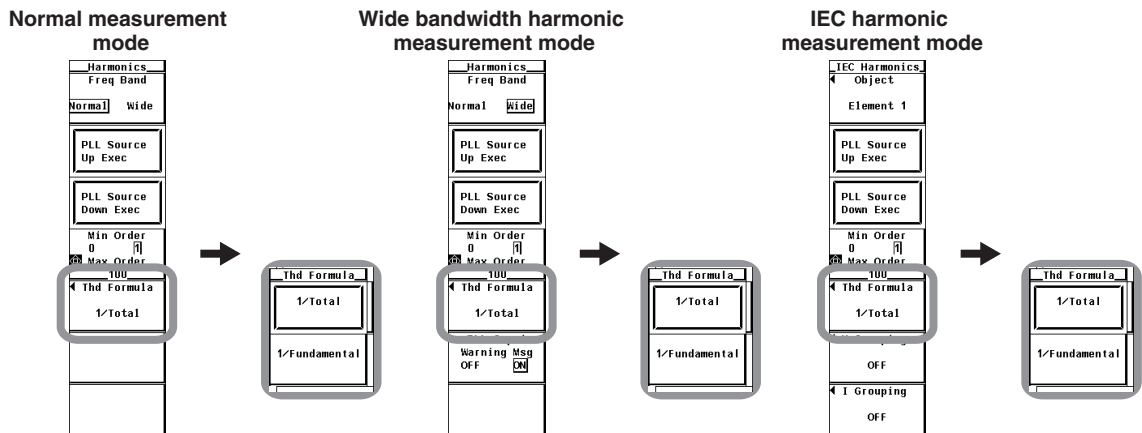

Explanation

When determining the measurement functions U_{hdf} , I_{hdf} , P_{hdf} , U_{thd} , I_{thd} , and P_{thd} of the harmonic measurement mode, select the denominator of the equation from the choices below. For the equations, see section 7.11.

- **1/Total**
The denominator is the measured data of all orders from the minimum measured order (0th or 1st) to the maximum measured order (within the upper limit of the measured order).
- **1/Fundamental**
The data of the fundamental signal component (1st order) become the denominator.

Note

The minimum and maximum harmonic orders to be measured are the values selected in section 7.6.

7.8 Setting the Anti-Aliasing Filter

Procedure

The diagram shows the instrument's soft key layout. The keys are arranged in several columns:

- Cursor keys:** RESET, SET, and four arrow keys (up, down, left, right).
- DISPLAY:** NUMERIC, WAVE, OTHERS, ITEM, FORM.
- ITEM & ELEMENT:** U/I/P, S/Q/λ/φ, WP/q/TIME, FU/FI/η, USER, ELEMENT, LOWER ITEM, LOWER FORM, USER SET, ALL.
- UPDATE RATE:** UPDATE RATE, HOLD, LOCAL.
- Other keys:** SCALING, LINE FILTER (circled), AVG, HRM SET, MEASURE, SYNC SOURCE, FILE, IMAGE SAVE, STORE, PRINT, MISC, HELP.

To exit the menu during operation, press **ESC** located above the soft keys.

In the procedural explanation below, the phrase “press the **cursor keys**” may be used. This phrase refers to the procedures for selecting items and entering values and character strings. For details on the procedures, see section 3.14 in the *User's Manual IM760301-01E*.

When making harmonic measurements, the line filter of normal measurement mode is used as an anti-aliasing filter.

- **Selecting the Line Filter**
 1. Press **LINE FILTER** to display the Line Filter menu.
Only the installed elements are displayed.
- **Selecting the Target Element**
 2. Press one of the soft keys corresponding to the displayed element to select the target element.
- **Selecting the Line Filter**
 3. Press the **cursor keys** to select any filter between OFF and 50 kHz. If any of the target elements is set to a setting other than OFF, the **LINE FILTER** key illuminates.

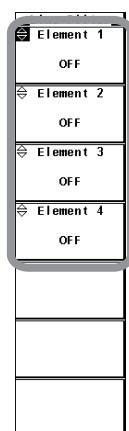

Explanation

When taking the FFT by performing A/D conversion on a repetitive waveform, a phenomenon occurs in which frequency components that exceed half the frequency of the sampling frequency are detected as low frequency components. This phenomenon is called aliasing.

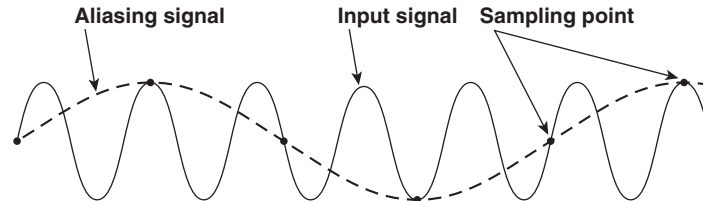

Aliasing causes problems such as increased errors in measured values and incorrect measurements of phase angles on the components of each order of the harmonic measurement. Therefore, an anti-aliasing filter is used to prevent aliasing and eliminate high frequency components that are irrelevant to the harmonic measurement.

For example, when measuring the input signal with a fundamental frequency of 50 Hz up to the 50th order, the frequency of the 50th order is 2.5 kHz. Thus, an 5.5-kHz anti-aliasing filter is used to eliminate high frequency components that are greater than or equal to approximately 5 kHz, which are irrelevant to the harmonic measurement.

The WT3000 uses the line filter in normal measurement mode as an anti-aliasing filter in harmonic measurement.

Selecting the Anti-Aliasing Filter (Line Filter)

- The cutoff frequency can be selected from the list of choices below.
OFF, 500 Hz, 5.5 kHz, and 50 kHz
- If any of the target elements is set to a setting other than OFF, the LINE FILTER key illuminates.
- Selecting OFF disables the anti-aliasing filter (line filter).
The accuracy and the upper limit of the measurement bandwidth change when the anti-aliasing filter (line filter) is turned ON. For details, see section 7.11.

Note

- The anti-aliasing filter (line filter) setting is common to all measurement modes. The filter setting does not change even if the measurement mode is changed.
- Accuracy may not be defined depending on the measurement mode. For example, the harmonic measurement in normal measurement mode assumes 50/60 Hz for the fundamental frequency. In this case, a 500-Hz anti-aliasing filter (line filter) would eliminate frequency components that are greater than or equal to 10th order, and is not appropriate. Therefore, accuracy is not defined for the 500-Hz line filter.

7.9 Displaying the Bar Graph and Making Cursor Measurements

Procedure

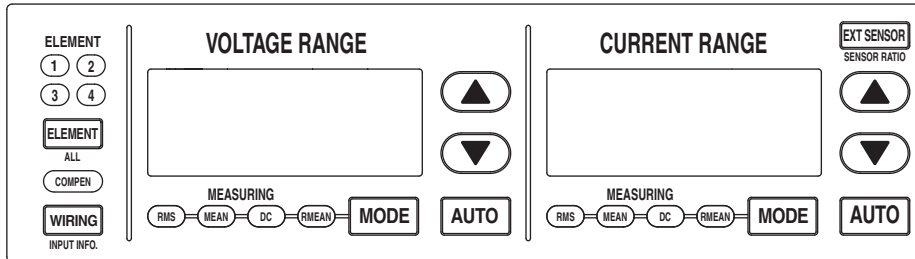

To exit the menu during operation, press **ESC** located above the soft keys.

In the procedural explanation below, the phrase “press the **cursor keys**” may be used. This phrase refers to the procedures for selecting items and entering values and character strings. For details on the procedures, see section 3.14 in the *User's Manual IM760301-01E*.

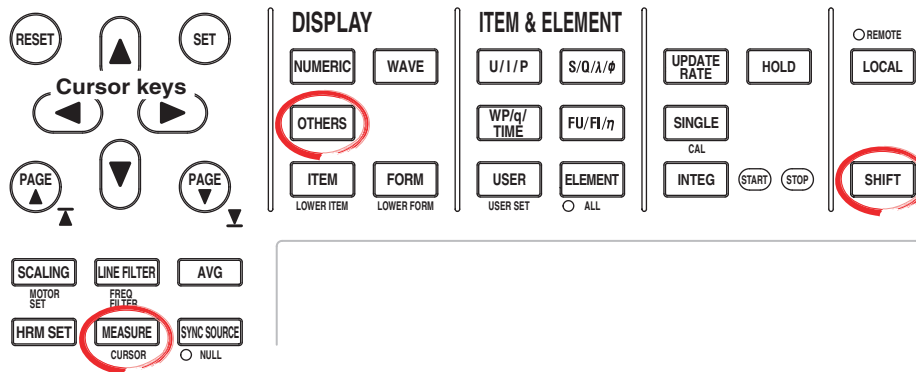

• Displaying Bar Graphs

1. Press **OTHERS** to display the Others menu.
2. Press any of the soft keys from **Bar**, **Numeric+Bar**, **Wave+Bar**, and **Bar+Trend** to select the display mode.

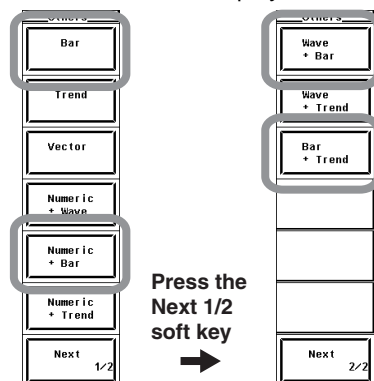

The following procedures are given as typical examples in which the display mode is set to Bar.

• Selecting the Item to Be Changed

3. Press **ITEM** to display the Bar Item menu.
If the bar graph is at the lower section of the screen on the split display, press **SHIFT+ITEM** (LOWER ITEM).
4. Press the **cursor keys** to select a value between 1 and 3.

• Changing the Measurement Function

5. Press the **Function** soft key to display the measurement function selection box.
6. Press the **cursor keys** to select the measurement function.
7. Press **SET**. The symbol for the selected measurement function and the bar graph are displayed.

• **Changing the Element**

8. Press the **Element** soft key to display the element selection box.
9. Press the **cursor keys** to select any of the elements/wiring units starting with Element1.
10. Press **SET**. The bar graph of the selected element number is displayed.

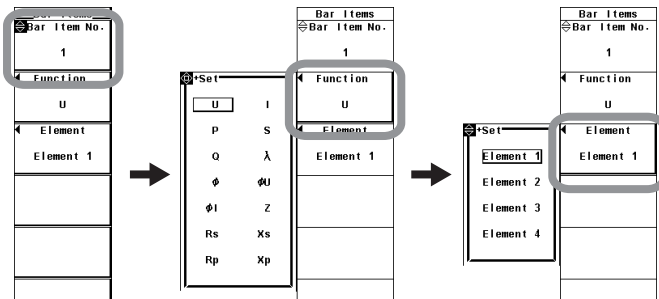

• **Selecting the Number of Split Windows for the Bar Graph**

11. Press **FORM** to display the Bar Form menu.
 - If the bar graph is displayed at the lower section of the screen on the split display, press SHIFT+FORM (LOWER FORM).
12. Press the **Format** soft key to display the Bar Format menu.
13. Press any of the keys from **Single** to **Triad** to select the number of windows.
 - If Single is selected, the bar graph of Bar Item No. 1 is displayed.
 - If Dual is selected, the bar graphs of Bar Item No. 1 and 2 are displayed.
 - If Triad is selected, the bar graphs of Bar Item No. 1 to 3 are displayed.

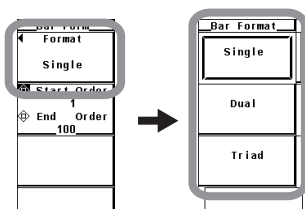

• **Setting the Display Range of the Bar Graph**

(The difference between the start order and the end order must be greater than or equal to 10.)

• **Setting the Start Order**

14. Press the **Start Order/End Order** soft key to set the cursor key target to Start Order.
15. Press the **cursor keys** to set the start order of the bar graph.

• **Setting the End Order**

14. Press the **Start Order/End Order** soft key to set the cursor key target to End Order.
15. Press the **cursor keys** to set the end order of the bar graph.

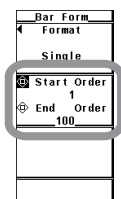

7.9 Displaying the Bar Graph and Making Cursor Measurements

- **Performing Cursor Measurements**

2. Press **SHIFT+MEASURE (CURSOR)** to display the Cursor menu.

- **Turning ON/OFF Cursor Measurement**

3. Press the **Bar Cursor** soft key to select ON or OFF.
If ON is selected, the result of the cursor measurement is displayed.

- **Moving the Cursors**

4. Press the **Bar C1 +/Bar C2 x** soft key to set the cursor target to Bar C1 +, Bar C2 x, or both Bar C1 + and Bar C2 x.
 - If you select Bar C1 +, the position of cursor + can be moved.
 - If you select Bar C2 x, the position of cursor x can be moved.
 - If you select both Bar C1 + and Bar C2 x, the two cursors can be moved without changing the spacing between the two. The value of the digit being specified by Bar C1 + changes.
5. Press the **cursor keys** to set and move the cursor position in terms of the harmonic order.

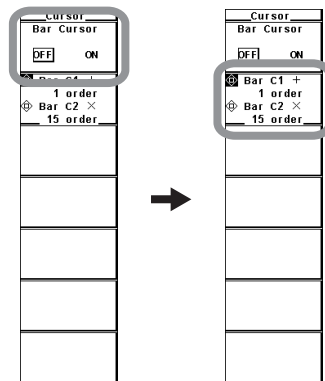

Explanation

A display example is shown below. The vertical axis is in logarithmic scale. The word <log Scale> appears at the top section of the screen.

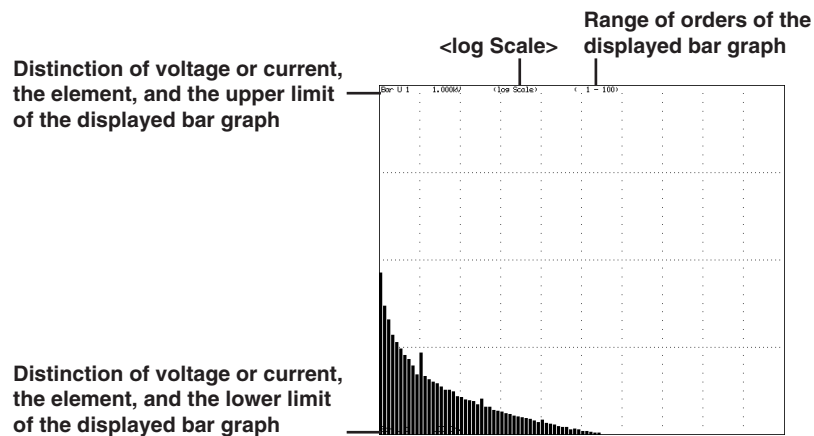

- **Selecting the Display Mode**

Select the bar graph display format from the choices below.

- **Displaying the Bar Graph on the Entire Screen**

Press Bar to display the bar graph on the entire screen.

- **Displaying the Bar Graph by Dividing the Screen into Halves (Split Display)**

- Numeric+Bar

The numeric data and bar graph are displayed separately in the top and bottom windows.

- Wave+Bar

The waveform and bar graph are displayed separately in the top and bottom windows.

- Bar+Trend

The bar graph and trend are displayed separately in the top and bottom windows.

- **Changing the Measurement Function**

Select the measurement function to be changed from the choices below.

U, I, P, S, Q, λ , ϕ , ϕU , ϕI , Z, Rs, Xs, Rp, and Xp

- **Changing the Element**

Select the element from the choices below. The selectable items vary depending on the installed elements.

Element1, Element2, Element3, and Element4

- **Selecting the Item to Be Changed**

Three types of bar graphs can be specified. Select the type from 1 (bar graph 1) to 3 (bar graph 3).

Note

- For data whose value is negative, the absolute value of the data is displayed with a red bar graph.
- If the analysis window width (frequency of the fundamental signal) that is determined by the fundamental frequency is shorter in time than the data update rate, the bar graph is not displayed. If this happens, decrease the data update rate. The details are the same as with harmonic data. See the note in section 7.3.

7.9 Changing the Displayed Items on the Bar Graph and Cursor Measurement

- **Setting the Display Range of the Bar Graph**
 - Set the display range of the bar graph using harmonic order.
 - The display range of bar graph 1 to bar graph 3 is the same.
 - The minimum value is 0th order (DC). However, if the measurement function is set to ϕ , ϕU , or ϕI , there is no value for the 0th order. Thus, 0th order is not displayed on the bar graph.
 - If the measurement function is set to ϕU or ϕI , there is no value for the 1st order. Thus, 1st order is not displayed on the bar graph.
 - The maximum setting is 100th order. However, bar graphs of orders that exceed the upper limit of the measured order (see section 7.9) are not displayed.
- **Cursor Measurement**
 - **ON/OFF**

A cursor can be placed on the displayed bar graph to measure the value at that point.

 - ON: Performs cursor measurement.
 - OFF: Does not perform cursor measurement.
 - **Measurement Item**
 - Y1+: Y-axis value of cursor + of bar graph 1
 - Y1x: Y-axis value of cursor x of bar graph 1
 - $\Delta Y1$: The difference between the Y-axis values of cursor + and cursor x of bar graph 1

 - Y2+: Y-axis value of cursor + of bar graph 2
 - Y2x: Y-axis value of cursor x of bar graph 2
 - $\Delta Y2$: The difference between the Y-axis values of cursor + and cursor x of bar graph 2

 - Y3+: Y-axis value of cursor + of bar graph 3
 - Y3x: Y-axis value of cursor x of bar graph 3
 - $\Delta Y3$: The difference between the Y-axis values of cursor + and cursor x of bar graph 3
 - **Moving the Cursor**
 - Two cursors (+ and x) are displayed in each graph (bar graphs 1 to 3).
 - The cursor position is set using harmonic order.
 - Bar graph displays the harmonic order indicating the cursor position.
 - The position of cursor + is displayed as in order+: 2.
 - The position of cursor x is displayed as in orderx: 55.
 - The harmonic order indicating the positions of cursor + and x are common to bar graph 1 to bar graph 3.

Note

If immeasurable data exists, *** is displayed in the measured value display area.

- **Limitations on the Bar Graph Display by Measurement Modes**

Bar graph of harmonic measurement cannot be displayed in the following measurement modes.

 - IEC harmonic measurement mode
 - Waveform computation mode
 - FFT mode
 - Voltage fluctuation and flicker measurement mode
 - Cycle-by-cycle measurement mode

7.10 Displaying Vectors

Procedure

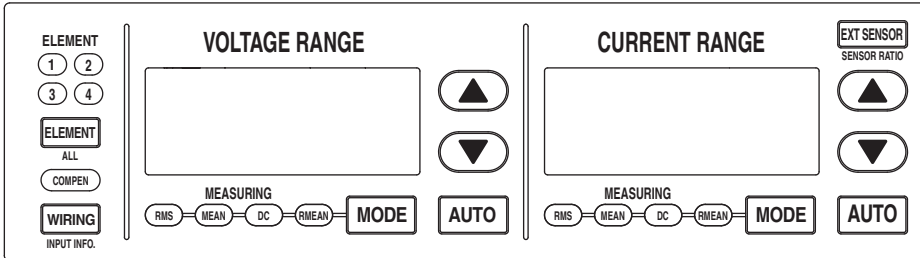

To exit the menu during operation, press **ESC** located above the soft keys.

In the procedural explanation below, the phrase “press the **cursor keys**” may be used. This phrase refers to the procedures for selecting items and entering values and character strings. For details on the procedures, see section 3.14 in the *User's Manual IM760301-01E*.

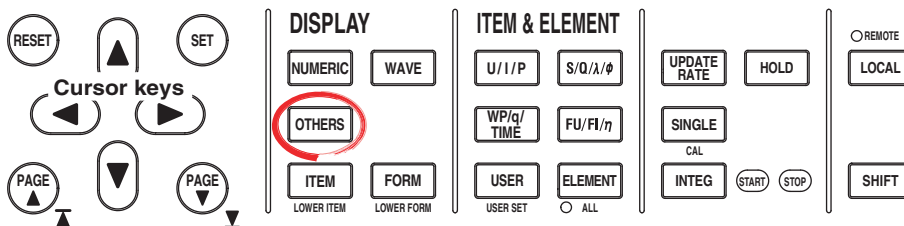

• Displaying Vectors

1. Press **OTHERS** to display the Others menu.
2. Press the **Vector** soft key to select the display mode.

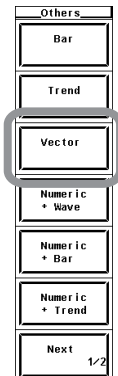

• Selecting the Wiring Unit to Be Displayed

3. Press **FORM** to display the Vector Form menu.
4. Press the **Object** soft key to display the Object menu.
5. Press the ΣA or ΣB soft key to select the wiring unit to be displayed.

• Turning ON/OFF the Numeric Data Display

Press the **Numeric** soft key to select ON or OFF.

7.10 Displaying Vectors

• Zooming in on the Vector

3. Press the **U Mag/I Mag** soft key to set the cursor key target to U Mag, I Mag, or both U Mag and I Mag.
 - If U Mag is selected, you can zoom in on the vector of the fundamental wave U(1) of each element that is specified for harmonic measurement.
 - If I Mag is selected, you can zoom in on the vector of the fundamental wave I(1) of each element that is specified for harmonic measurement.
 - If both U Mag and I Mag is selected, you can zoom in on the vector of the fundamental waves U(1) and I(1) of each element that are specified for harmonic measurement without changing the difference in the zoom factor between U Mag and I Mag. The value of the digit being specified by U Mag changes.
4. Press the **cursor keys** to set the zoom factor.

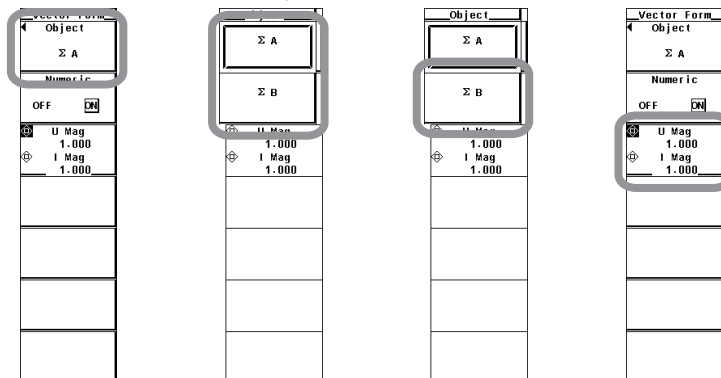

Explanation

The phase and size (rms value) relationship between the fundamental waves U(1) and I(1) of each element in the wiring unit of ΣA or ΣB can be displayed using vectors. The positive vertical axis is set to 0 (angle zero), and the vector of each input signal is displayed.

Note

If the analysis window width (frequency of the fundamental signal) that is determined by the fundamental frequency is shorter in time than the data update rate, the vector is not displayed. If this happens, decrease the data update rate. The details are the same as with harmonic data. See the note in section 7.3.

• Turning ON/OFF the Numeric Data Display

Select whether to display the numeric data (ON/OFF). The size and the phase difference between the signals can be displayed along with the vector display. For the display format of the phase difference, see section 5.10 in the *User's Manual IM760301-01E*.

• Setting the Zoom Factor of Vectors

The size of the vectors can be changed.

- The zoom factor can be set in the range of 0.100 to 100.000.
- You can specify separate zoom factors for the fundamental waves U(1) and I(1).

Note

If all the wiring systems are single-phase two-wire (1P2W) or if you are using the single input element model (760301), Σ wiring units do not exist. Therefore, nothing is displayed on the vector display.

• Limitations on the Vector Display by Measurement Modes

Vectors cannot be displayed in the following measurement modes.

- IEC harmonic measurement mode
- Waveform computation mode
- FFT mode
- Voltage fluctuation and flicker measurement mode
- Cycle-by-cycle measurement mode

Vector Display Examples

When Displaying Numeric Data (the size of the signal and the phase difference between signals)

- For a 3P4W (three-phase four-wire) wiring system
- U1(1), U2(1), and U3(1) are common mode voltages.
 - I1(1), I2(1), and I3(1) are line currents.

- For a 3V3A (three-voltage, three-current) wiring system
- U1(1), U2(1), and U3(1) are line voltages.
 - I1(1), I2(1), and I3(1) are line currents.

- For a 3P3W (three-phase three-wire) wiring system
- U1(1), U2(1), and U3(1) are line voltages.
 - I1(1), I2(1), and I3(1) are line currents. However, U3(1) and I3(1) are not actually measured for the 3P3W system. The vectors are displayed through computation.

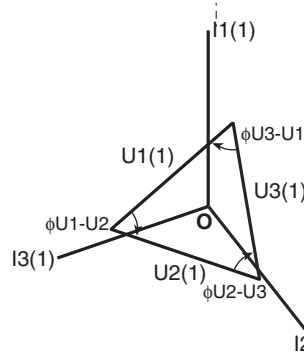
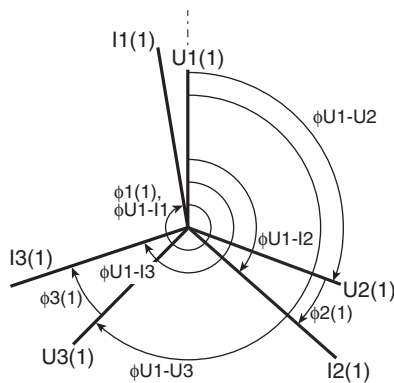
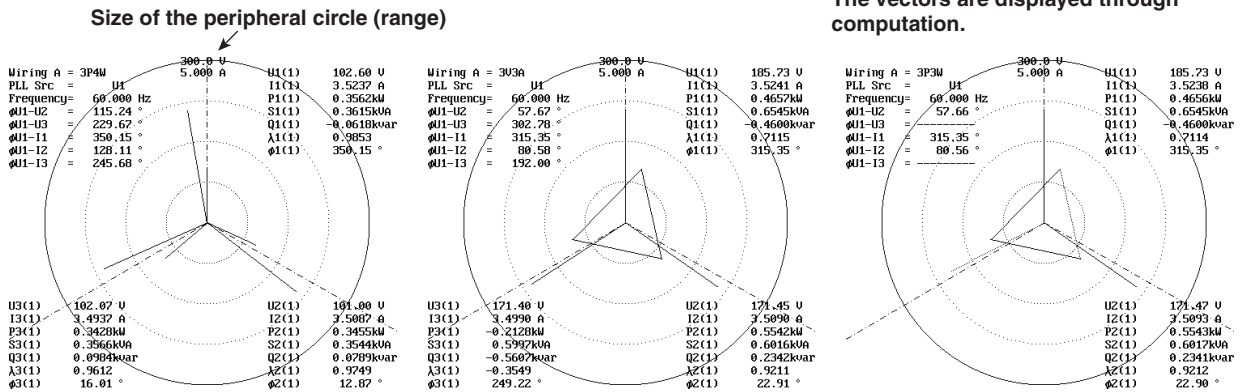

- By moving the vectors, U1(1), U2(1), and U3(1), so that the starting points of vectors are all at the origin O, the phase relationship can be observed in the same fashion as the 3P3W system. For the relationship between the positions of the vectors after moving them, see "Vector Display of Harmonics" in section 7.1, "Vector Display of Harmonics." (The WT3000 does not provide a function for moving the vectors.)
- The phase difference between the line voltages can be determined from the phase difference measurement functions ϕ_{U1-U2} and ϕ_{U1-U3} .
 $\phi_{U1-U2} = \text{This is the measurement function } \phi_{U1-U2}.$
 $\phi_{U2-U3} = (\phi_{U1-U3}) - (\phi_{U1-U2}) - 180^\circ$
 $\phi_{U3-U1} = -(\phi_{U1-U3})$

When the vector size is zoomed

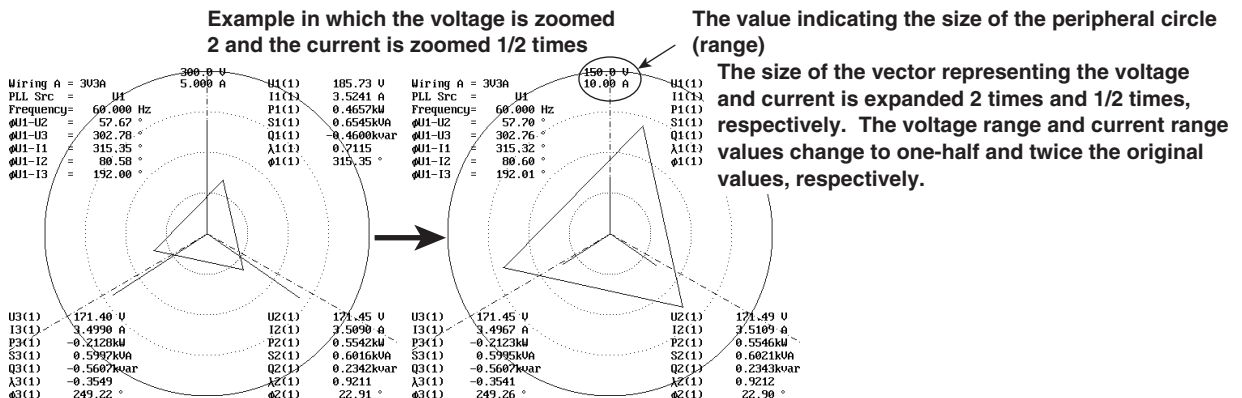

7.11 Harmonic Measurement Specifications

Item	Specifications
Measured source	All installed elements
Format	PLL synchronization method
Frequency range	Fundamental frequency of the PLL source is in the range of 10 Hz to 440 Hz (/G5 option). Fundamental frequency of the PLL source is in the range of 10 Hz to 2600 Hz (/G6 option).
PLL source	<ul style="list-style-type: none"> Select the voltage or current of each input element (external current sensor range is greater than or equal to 500 mV) or the external clock (Ext Clk). Input level Greater than or equal to 50% of the measurement range rating when the crest factor is 3 Greater than or equal to 100% of the measurement range rating when the crest factor is 6 Turn the frequency filter ON when the fundamental frequency is less than or equal to 440 Hz.
Measurement function	See the next section.
FFT data length	9000
FFT processing word length	32 bits
Window function	Rectangular
Anti-aliasing filter	Set using a line filter (5.5 kHz or 50 kHz).

Sample rate (sampling frequency), window width, and upper limit of measured order during PLL synchronization

On models with the harmonic measurement (/G5) option

Fundamental Frequency of the PLL Source (Hz)	Sample Rate (S/s)	Window Width against the FFT Data Length (Frequency of the Fundamental Wave)	Upper Limit of the Measured Order
10 to 20	$f \times 3000$	3	100
20 to 40	$f \times 1500$	6	100
40 to 55	$f \times 900$	10	100
55 to 75	$f \times 750$	12	100
75 to 150	$f \times 450$	20	50
150 to 440	$f \times 150$	60	15

On models with the advanced computation (/G6) option

Fundamental Frequency of the PLL Source (Hz)	Sample Rate (S/s)	Window Width against the FFT Data Length (Frequency of the Fundamental Wave)	Upper Limit of the Measured Order
10 to 20	$f \times 3000$	3	100
20 to 40	$f \times 1500$	6	100
40 to 55	$f \times 900$	10	100
55 to 75	$f \times 750$	12	100
75 to 150	$f \times 450$	20	50
150 to 440	$f \times 360$	25	15
440 to 1100	$f \times 150$	60	7
1100 to 2600	$f \times 60$	150	3

For the specifications of the wide bandwidth harmonic measurement and IEC harmonic measurement, see chapters 8 and 9.

Accuracy

On models with the harmonic measurement (/G5) option

- When the line filter (5.5 kHz) is ON

Frequency	Voltage and Current ±(reading error + measurement range error)	Power ±(reading error + measurement range error)
10 Hz ≤ f < 30 Hz	0.25% of reading + 0.3% of range	0.5% of reading + 0.4% of range
30 Hz ≤ f ≤ 66 Hz	0.2% of reading + 0.15% of range	0.4% of reading + 0.15% of range
66 Hz < f ≤ 440 Hz	0.5% of reading + 0.15% of range	1.2% of reading + 0.15% of range
440 Hz < f ≤ 1 kHz	1.2% of reading + 0.15% of range	2% of reading + 0.15% of range
1 kHz < f ≤ 2.5 kHz	2.5% of reading + 0.15% of range	6% of reading + 0.2% of range

- When the line filter (50 kHz) is ON

Frequency	Voltage and Current ±(reading error + measurement range error)	Power ±(reading error + measurement range error)
10 Hz ≤ f < 30 Hz	0.25% of reading + 0.3% of range	0.45% of reading + 0.4% of range
30 Hz ≤ f ≤ 440 Hz	0.2% of reading + 0.15% of range	0.4% of reading + 0.15% of range
440 Hz < f ≤ 2.5 kHz	1% of reading + 0.15% of range	2% of reading + 0.2% of range
2.5 kHz < f ≤ 5 kHz	2% of reading + 0.15% of range	4% of reading + 0.2% of range
5 kHz < f ≤ 7.5 kHz	3.5% of reading + 0.15% of range	6.5% of reading + 0.2% of range

- When the line filter is OFF

Frequency	Voltage and Current ±(reading error + measurement range error)	Power ±(reading error + measurement range error)
10 Hz ≤ f < 30 Hz	0.15% of reading + 0.3% of range	0.25% of reading + 0.4% of range
30 Hz ≤ f ≤ 440 Hz	0.1% of reading + 0.15% of range	0.2% of reading + 0.15% of range
440 Hz < f ≤ 2.5 kHz	0.6% of reading + 0.15% of range	1.2% of reading + 0.2% of range
2.5 kHz < f ≤ 5 kHz	1.6% of reading + 0.15% of range	3.2% of reading + 0.2% of range
5 kHz < f ≤ 7.5 kHz	2.5% of reading + 0.15% of range	5% of reading + 0.2% of range

However, all the items below apply to all the tables.

- When averaging is ON, the averaging type is EXP, and the attenuation constant is greater than or equal to 8.
- When the crest factor is set to 3
- When λ (power factor) = 1
- Power figures that exceed 440 Hz are reference values.
- For external current sensor range, add 0.2 mV to the current accuracy, and add $(0.2 \text{ mV} / \text{external current sensor range rating}) \times 100\%$ of range to the power accuracy.
- For direct current input range, add 0.2 mA to the current accuracy, and add $(0.2 \text{ mA} / \text{direct current input range rating}) \times 100\%$ of range to the power accuracy.
- For n^{th} order component input, add $\{n/(m+1)\}/50\%$ of (the n^{th} order reading) to the $n+m^{\text{th}}$ order and $n-m^{\text{th}}$ order of the voltage and current, and add $\{n/(m+1)\}/25\%$ of (the n^{th} order reading) to the $n+m^{\text{th}}$ order and $n-m^{\text{th}}$ order of the power.
- Add $(n/500)\%$ of reading to the n^{th} component of the voltage and current, and add $(n/250)\%$ of reading to the n^{th} component of the power.
- Accuracy when the crest factor is 6: The same as when the range is doubled for crest factor 3. If the amplitude of the high frequency component is large, influence of approximately 1% may appear in certain orders. The influence depends on the size of the frequency component. Therefore, if the frequency component is small with respect to the range rating, this does not cause a problem.

7.11 Harmonic Measurement Specifications

Accuracy

On models with the advanced computation (/G6) option

- When the line filter (5.5 kHz) is ON

Frequency	Voltage and Current ±(reading error + measurement range error)	Power ±(reading error + measurement range error)
10 Hz ≤ f < 30 Hz	0.25% of reading + 0.3% of range	0.5% of reading + 0.4% of range
30 Hz ≤ f ≤ 66 Hz	0.2% of reading + 0.15% of range	0.4% of reading + 0.15% of range
66 Hz < f ≤ 440 Hz	0.5% of reading + 0.15% of range	1.2% of reading + 0.15% of range
440 Hz < f ≤ 1 kHz	1.2% of reading + 0.15% of range	2% of reading + 0.15% of range
1 kHz < f ≤ 2.5 kHz	2.5% of reading + 0.15% of range	6% of reading + 0.2% of range
2.5 kHz < f ≤ 3.5 kHz	8% of reading + 0.15% of range	16% of reading + 0.3% of range

If the fundamental frequency is between 1 kHz and 2.6 kHz, add 0.5% of reading to the voltage and current accuracy and 1% of reading to the power accuracy when the frequency exceeds 1 kHz.

- When the line filter (50 kHz) is ON

Frequency	Voltage and Current ±(reading error + measurement range error)	Power ±(reading error + measurement range error)
10 Hz ≤ f < 30 Hz	0.25% of reading + 0.3% of range	0.45% of reading + 0.4% of range
30 Hz ≤ f ≤ 440 Hz	0.2% of reading + 0.15% of range	0.4% of reading + 0.15% of range
440 Hz < f ≤ 2.5 kHz	1% of reading + 0.15% of range	2% of reading + 0.2% of range
2.5 kHz < f ≤ 5 kHz	2% of reading + 0.15% of range	4% of reading + 0.2% of range
5 kHz < f ≤ 7.8 kHz	3.5% of reading + 0.15% of range	6% of reading + 0.2% of range

If the fundamental frequency is between 1 kHz and 2.6 kHz, add 0.5% of reading to the voltage and current accuracy and 1% of reading to the power accuracy when the frequency exceeds 1 kHz.

- When the line filter is OFF

Frequency	Voltage and Current ±(reading error + measurement range error)	Power ±(reading error + measurement range error)
10 Hz ≤ f < 30 Hz	0.15% of reading + 0.3% of range	0.25% of reading + 0.4% of range
30 Hz ≤ f ≤ 440 Hz	0.1% of reading + 0.15% of range	0.2% of reading + 0.15% of range
440 Hz < f ≤ 2.5 kHz	0.6% of reading + 0.15% of range	1.2% of reading + 0.2% of range
2.5 kHz < f ≤ 5 kHz	1.6% of reading + 0.15% of range	3.2% of reading + 0.2% of range
5 kHz < f ≤ 7.8 kHz	2.5% of reading + 0.15% of range	5% of reading + 0.2% of range

If the fundamental frequency is between 1 kHz and 2.6 kHz, add 0.5% of reading to the voltage and current accuracy and 1% of reading to the power accuracy when the frequency exceeds 1 kHz.

However, all the items below apply to all tables.

- When averaging is ON, the averaging type is EXP, and the attenuation constant is greater than or equal to 8.
- When the crest factor is set to 3
- When λ (power factor) = 1
- Power exceeding 440 Hz are reference value.
- For external current sensor range, add 0.2 mV to the current accuracy and add $(0.2 \text{ mV}/\text{external current sensor range rating}) \times 100\%$ of range to the power accuracy.
- For direct current input range on the 30-A input element, add 0.2 mA to the current accuracy and add $(0.2 \text{ mA}/\text{direct current input range rating}) \times 100\%$ of range to the power accuracy.
- For direct current input range on the 2-A input element, add 2 μA to the current accuracy and add $(2 \text{ } \mu\text{A}/\text{direct current input range rating}) \times 100\%$ of range to the power accuracy.
- For n^{th} order component input, add $(\{n/(m+1)\}/50)\%$ of (the n^{th} order reading) to the $n+m^{\text{th}}$ order and $n-m^{\text{th}}$ order of the voltage and current, and add $(\{n/(m+1)\}/25)\%$ of (the n^{th} order reading) to the $n+m^{\text{th}}$ order and $n-m^{\text{th}}$ order of the power.
- Add $(n/500)\%$ of reading to the n^{th} component of the voltage and current, and add $(n/250)\%$ of reading to the n^{th} component of the power.
- Accuracy when the crest factor is 6: The same as when the range is doubled for crest factor 3.
- The accuracy guaranteed range by frequency and voltage/current is the same as the guaranteed range of normal measurement.

If the amplitude of the high frequency component is large, influence of approximately 1% may appear in certain orders. The influence depends on the size of the frequency component.

Therefore, if the frequency component is small with respect to the range rating, this does not cause a problem.

Measurement Functions Determined for Each Input Element

Item	Symbol and Meaning
Voltage (V)	U(k): rms value of the harmonic voltage of order k ¹ U: Rms voltage (total value ²)
Current (A)	I(k): rms value of the harmonic current of order k I: Rms current (total value ²)
Active power (W)	P(k): Active power of the harmonic signal of order k P: Active power (total value ²)
Apparent power (VA)	S(k): Apparent power of the harmonic signal of order k S: Total apparent power (total value ²)
Reactive power (var)	Q(k): Reactive power of the harmonic signal of order k Q: Total reactive power (total value ²)
Power factor	$\lambda(k)$: Power factor of the harmonic signal of order k I: Total power factor (total value ²)
Phase difference (°)	$\phi(k)$: Phase difference between the harmonic voltage and current of order k, ϕ : total phase $\phi U(k)$: Phase difference of each harmonic voltage U(k) with respect to the fundamental signal U(1) $\phi I(k)$: Phase difference of each harmonic current I(k) with respect to the fundamental signal I(1)
Impedance ³ (Ω) of the load circuit	Z(k): Impedance of the load circuit observed by the k th order harmonic signal.
Resistance ³ and reactance ³	Rs(k): Resistance observed by the k th order harmonic signal of the load circuit that has a resistor R, (Ω) of the load circuit inductor L, and capacitor C connected in series Xs(k): Reactance observed by the k th order harmonic signal of the load circuit that has a resistor R, inductor L, and capacitor C connected in series Rp(k): Resistance observed by the k th order harmonic signal of the load circuit that has a resistor R, inductor L, and capacitor C connected in parallel Xp(k): Reactance observed by the k th order harmonic signal of the load circuit that has a resistor R, inductor L, and capacitor C connected in parallel
Harmonic distortion factor [%]	Uhdf(k): The ratio of the harmonic voltage U(k) to U(1) or U expressed as a percentage. Ihdf(k): The ratio of the harmonic current I(k) to I(1) or I expressed as a percentage. Phdf(k): The ratio of the active power P(k) of the harmonic signal to P(1) or P expressed as a percentage.
Total harmonic distortion [%]	Uthd: The ratio of the total harmonic voltage to U(1) or U ⁴ expressed as a percentage. Ithd: The ratio of the total harmonic current to I(1) or I expressed as a percentage. Pthd: The ratio of the active power of the total harmonic signal to P(1) or P expressed as a percentage.
Telephone harmonic factor ^{3,5} (Applicable standard IEC34-1(1996))	Uthf: Voltage telephone harmonic factor, Ithf: Current telephone harmonic factor
Telephone influence factor ^{3,5} (Applicable standard IEEE Std 100(1996))	Utif: Voltage telephone influence factor, Itif: Current telephone influence factor
Harmonic voltage factor ^{3,6} hvf:	harmonic voltage factor
Harmonic current factor ^{3,6} hcf:	harmonic current factor

*1 Order k is an integer in the range from 0 to the upper limit of the measured order. 0th order is the DC component. The upper limit is determined automatically (maximum is 100th) by the frequency of the PLL source.

*2 The total is a value determined according to the equation given on page 7-38 from the fundamental signal (1st order) and all harmonic components (2nd to the upper limit of the measured order). The DC component can also be included. The total value cannot be measured with the harmonic measurement in normal measurement mode.

*3 Cannot be measured in IEC harmonic measurement mode.

*4 Total harmonic is a value determined according to the equation given in the next section from all harmonic components (2nd to the upper limit of measured order).

*5 Measurement functions specific to the IEC or IEEE standard.

*6 The equation may vary depending on the definitions given in the respective standard. For details, see the respective standard.

7.11 Harmonic Measurement Specifications

Measurement Functions Indicating the Phase Difference of the Fundamental Voltage and Current between Elements

These measurement functions express the phase difference of fundamental wave $U(1)$ and $I(1)$ of other elements with respect to the fundamental wave $U(1)$ of the element with the smallest number of the input elements that are assigned to the wiring unit. The following table indicates the measurement functions for a wiring unit that combines elements 1, 2, and 3.

Item	Symbol and Meaning
Phase difference U1-U2 (°)	ϕ_{U1-U2} : Phase difference of the fundamental voltage ($U2(1)$) of element 2 with respect to the fundamental voltage ($U1(1)$) of element 1.
Phase difference U1-U3 (°)	ϕ_{U1-U3} : Phase difference of the fundamental voltage ($U3(1)$) of element 3 with respect to $U1(1)$.
Phase difference U1-I1 (°)	ϕ_{U1-I1} : Phase difference of the fundamental current ($I1(1)$) of element 1 with respect to $U1(1)$.
Phase difference U1-I2 (°)	ϕ_{U1-I2} : Phase difference of the fundamental current ($I2(1)$) of element 2 with respect to $U1(1)$.
Phase difference U1-I3 (°)	ϕ_{U1-I3} : Phase difference of the fundamental current ($I3(1)$) of element 3 with respect to $U1(1)$.

Measurement Functions (Σ Functions) Determined for Each Wiring Unit (ΣA and ΣB)

Item	Symbol and Meaning
Voltage (V)	$U_{\Sigma}(1)$: rms value of the harmonic voltage of order 1 U_{Σ} : Rms voltage (total value ^{*1})
Current (A)	$I_{\Sigma}(1)$: rms value of the harmonic current of order 1 I_{Σ} : Rms current (total value ^{*1})
Active power (W)	$P_{\Sigma}(1)$: Active power of the harmonic signal of order 1 P_{Σ} : Active power (total value ^{*1})
Apparent power (VA)	$S_{\Sigma}(1)$: Apparent power of the harmonic signal of order 1 S_{Σ} : Total apparent power (total value ^{*1})
Reactive power (var)	$Q_{\Sigma}(1)$: Reactive power of the harmonic signal of order 1 Q_{Σ} : Total reactive power (total value ^{*1})
Power factor	$\lambda_{\Sigma}(1)$: Power factor of the harmonic signal of order 1 λ_{Σ} : Total power factor (total value ^{*1})

*1 The total is a value determined according to the equation given on page 7-38 from the fundamental signal (1st order) and all harmonic components (2nd to the upper limit of the measured order). The DC component can also be included. The total value cannot be measured with the harmonic measurement in normal measurement mode.

Determination of Measurement Functions during Harmonic Measurement

(Table 1/3)

Measurement Functions during Harmonic Measurement	Method of Determination, Equation			Total {No ()}
	Characters/Numbers inside the parentheses of measurement functions			
	dc (when k = 0)	1 (when k = 1)	k (When k = 2 to max)	
Voltage U() [V]	$U(\text{dc}) = U_r(0)$	$U(k) = \sqrt{U_r(k)^2 + U_j(k)^2}$		$U = \sqrt{\sum_{k=\text{min}}^{\text{max}} U(k)^2}$
Current I() [A]	$I(\text{dc}) = I_r(0)$	$I(k) = \sqrt{I_r(k)^2 + I_j(k)^2}$		$I = \sqrt{\sum_{k=\text{min}}^{\text{max}} I(k)^2}$
Active power P() [W]	$P(\text{dc}) = U_r(0) \cdot I_r(0)$	$P(k) = U_r(k) \cdot I_r(k) + U_j(k) \cdot I_j(k)$		$P = \sum_{k=\text{min}}^{\text{max}} P(k)$
Apparent power S() [VA] (TYPE3)*	$S(\text{dc}) = P(\text{dc})$	$S(k) = \sqrt{P(k)^2 + Q(k)^2}$		$S = \sqrt{P^2 + Q^2}$
Reactive power Q() [var] (TYPE3)*	$Q(\text{dc}) = 0$	$Q(k) = U_r(k) \cdot I_j(k) - U_j(k) \cdot I_r(k)$		$Q = \sum_{k=\text{min}}^{\text{max}} Q(k)$
Power factor $\lambda()$	$\lambda(\text{dc}) = \frac{P(\text{dc})}{S(\text{dc})}$	$\lambda(k) = \frac{P(k)}{S(k)}$		$\lambda = \frac{P}{S}$
Phase difference $\phi()$ [°]	—	$\phi(k) = \tan^{-1} \left\{ \frac{Q(k)}{P(k)} \right\}$		$\phi = \cos^{-1} \left(\frac{P}{S} \right)$
Phase difference with respect to U(1) $\phi_U()$ [°]	—	$\phi_U(k) = \text{Phase difference of } U(k) \text{ with respect to } U(1)$		—
Phase difference with respect to I(1) $\phi_I()$ [°]	—	$\phi_I(k) = \text{Phase difference of } I(k) \text{ with respect to } I(1)$		—
Impedance of the load circuit Z() [Ω]	$Z(\text{dc}) = \left \frac{U(\text{dc})}{I(\text{dc})} \right $	$Z(k) = \left \frac{U(k)}{I(k)} \right $		—
Series resistance of the load circuit Rs() [Ω]	$R_s(\text{dc}) = \frac{P(\text{dc})}{I(\text{dc})^2}$	$R_s(k) = \frac{P(k)}{I(k)^2}$		—
Series reactance of the load circuit Xs() [Ω]	$X_s(\text{dc}) = \frac{Q(\text{dc})}{I(\text{dc})^2}$	$X_s(k) = \frac{Q(k)}{I(k)^2}$		—
Parallel resistance of the load circuit Rp() [Ω] (= 1/G)	$R_p(\text{dc}) = \frac{U(\text{dc})^2}{P(\text{dc})}$	$R_p(k) = \frac{U(k)^2}{P(k)}$		—
Parallel reactance of the load circuit Xp() [Ω] (= 1/B)	$X_p(\text{dc}) = \frac{U(\text{dc})^2}{Q(\text{dc})}$	$X_p(k) = \frac{U(k)^2}{Q(k)}$		—

(Continues on the next page)

* For details on the type of S and Q equations, see section 5.9 in the *User's Manual IM760301-01E*.**Note**

- Variables k, r, and j denote the harmonic order, real part, and imaginary part, respectively.
- Variables U(k), Ur(k), Uj(k), I(k), Ir(k), and Ij(k) are expressed using rms values.
- min denotes the minimum order. You can select 0 (DC component) or 1 (fundamental signal component) for the minimum order. For details, see section 7.5.
- Variable max is the upper limit of measured order. The upper limit is determined automatically (maximum is 100) by the frequency of the PLL source.

7.11 Harmonic Measurement Specifications

(Table 2/3)

Measurement Functions during Harmonic Measurement	Method of Determination, Equation	
	Characters/Numbers inside the parentheses of measurement functions are dc (when k = 0) and k (when k = 1 to max).	
	When the numerator of the distortion factor equation is all (Total)	When the numerator of the distortion factor equation is fundamental
Voltage harmonic distortion factor U _{hdf} () [%]	$\frac{U(k)}{U(\text{Total})} \cdot 100$	$\frac{U(k)}{U(1)} \cdot 100$
Current harmonic distortion factor I _{hdf} () [%]	$\frac{I(k)}{I(\text{Total})} \cdot 100$	$\frac{I(k)}{I(1)} \cdot 100$
Active power harmonic distortion factor P _{hdf} () [%]	$\frac{P(k)}{P(\text{Total})} \cdot 100$	$\frac{P(k)}{P(1)} \cdot 100$
Total harmonic distortion of voltage U _{thd} [%]	$\frac{\sqrt{\sum_{k=2}^{\max} U(k)^2}}{U(\text{Total})} \cdot 100$	$\frac{\sqrt{\sum_{k=2}^{\max} U(k)^2}}{U(1)} \cdot 100$
Total harmonic distortion of current I _{thd} [%]	$\frac{\sqrt{\sum_{k=2}^{\max} I(k)^2}}{I(\text{Total})} \cdot 100$	$\frac{\sqrt{\sum_{k=2}^{\max} I(k)^2}}{I(1)} \cdot 100$
Total harmonic distortion of active power P _{thd} [%]	$\frac{\sum_{k=2}^{\max} P(k)}{P(\text{Total})} \cdot 100$	$\frac{\sum_{k=2}^{\max} P(k)}{P(1)} \cdot 100$
Voltage telephone harmonic factor U _{thf} [%] Current telephone harmonic factor I _{thf} [%]	$U_{thf} = \frac{1}{U(\text{Total})^{*2}} \sqrt{\sum_{k=1}^{\max} \{\lambda(k) \cdot U(k)\}^2} \cdot 100 \quad I_{thf} = \frac{1}{I(\text{Total})^{*2}} \sqrt{\sum_{k=1}^{\max} \{\lambda(k) \cdot I(k)\}^2} \cdot 100$ <p style="text-align: center;">Constant defined in the applicable standard (IEC34-1(1996))</p>	
Voltage telephone influence factor U _{tif} Current telephone influence factor I _{tif}	$U_{tif} = \frac{1}{U(\text{Total})^{*2}} \sqrt{\sum_{k=1}^{\max} \{T(k) \cdot U(k)\}^2} \quad I_{tif} = \frac{1}{I(\text{Total})^{*2}} \sqrt{\sum_{k=1}^{\max} \{T(k) \cdot I(k)\}^2}$ <p style="text-align: center;">Constant defined in the applicable standard (IEEE Std 100(1992))</p>	
Harmonic voltage factor hvf [%] ^{*1} Harmonic current factor hcf [%] ^{*1}	$hvf = \frac{1}{U(\text{Total})^{*2}} \sqrt{\sum_{k=2}^{\max} \frac{U(k)^2}{k}} \cdot 100$	$hcf = \frac{1}{I(\text{Total})^{*2}} \sqrt{\sum_{k=2}^{\max} \frac{I(k)^2}{k}} \cdot 100$

(Continues on the next page)

*1 The equation varies depending on the definitions in the relevant standard. For details see the standard (IEC34-1:1996).

$$*2 \quad U(\text{Total}) = \sqrt{\sum_{k=\min}^{\max} U(k)^2}, \quad I(\text{Total}) = \sqrt{\sum_{k=\min}^{\max} I(k)^2}, \quad P(\text{Total}) = \sum_{k=\min}^{\max} P(k)$$

Note

- Variables k, r, and j denote the harmonic order, real part, and imaginary part, respectively.
- Variable min is the minimum measured order.
- Variable max is the upper limit of measured order. The upper limit is determined automatically (maximum is 100) by the frequency of the PLL source.

(Table 3/3)

Measurement Functions during Harmonic Measurement		Method of Determination, Equation			
		Single-phase, three-wire (1P3W)	Three-phase, three-wire (3P3W)	Three-voltage, three-current (3V3A)	Three-phase, four-wire (3P4W)
Σ function	Wiring system				
	U_{Σ} [V]	$(U1 + U2) / 2$		$(U1 + U2 + U3) / 3$	
	I_{Σ} [A]	$(I1 + I2) / 2$		$(I1 + I2 + I3) / 3$	
	P_{Σ} [W]	$P1 + P2$			$P1 + P2 + P3$
	S_{Σ} [VA] (TYPE3)*	$\sqrt{P_{\Sigma}^2 + Q_{\Sigma}^2}$			
	Q_{Σ} [var] (TYPE3)*	$Q1 + Q2$			$Q1 + Q2 + Q3$
	λ_{Σ}	$\frac{P_{\Sigma}}{S_{\Sigma}}$			

* For details on the type of S_{Σ} and Q_{Σ} equations, see section 5.9 in the *User's Manual IM760301-01E*.

Note

- The numbers 1, 2, and 3 in the equations U_{Σ} , I_{Σ} , P_{Σ} , S_{Σ} , and Q_{Σ} indicate the case when input elements 1, 2, and 3 are set to the wiring system shown in the table. If elements 2, 3, and 4 are set to the wiring system shown in the table, replace the numbers 1, 2, and 3 with 2, 3, and 4, respectively.
- For Σ , only the total value and fundamental wave (1st) are computed.

8.1 Wide Bandwidth Harmonic Measurement Function

Harmonic measurement up to 50th order can be performed on a signal with a 1-kHz fundamental frequency. Use this mode for harmonic measurement of signals whose fundamental frequency is higher than the commercial power supply frequency. By applying an external sampling clock, harmonics can be measured on low frequency signals with a fundamental frequency of 0.1 Hz. The harmonics of inverters that drive motors at low frequency (low revolution) can be measured.

- **Limitations on the Function and Measurement Function**

Wide bandwidth measurement mode performs internal computation differently from other measurement modes in order to achieve the harmonic measurement of high frequency signals. Therefore, some functions such as waveform and trend display on the screen and motor evaluation function (motor version) cannot be used in this measurement mode. In addition, some measurement functions such as peak measurement, integration, and efficiency computation cannot be carried out. For a list of functions with limitations and measurement functions that cannot be measured, see appendix 10 and 11 in the *User's Manual IM760301-01E*.

- **Differences from Other Harmonic Measurement Modes**

For the differences from the harmonic measurement in normal measurement mode and IEC harmonic measurement mode, see "Harmonic Measurement Types" in section 7.1.

- **Voltage/Current Mode and Measured Values of Voltage U and Current I**

The voltage/current mode settings are invalid in wide bandwidth harmonic measurement mode. The voltage/current mode LED turns OFF. The voltage U and current I values that are measured in this measurement mode are total values. For details on the total value, see "Relationship between the Rms Values of Voltage U/ Current I and Measurement Modes" in section 7.1.

- **Description of Other Functions Related to Harmonic Measurement**

For a functional description of the items below, see section 7.1.

- Types of harmonic measurement functions
- Measurement period of harmonic measurement functions
- Numeric display related to harmonic measurement
- Equation for distortion factor
- Bar graph display
- Vector display

8.2 Various Settings Related to Wide Bandwidth Harmonic Measurement

Most of the operations of wide bandwidth harmonic measurement mode are common with the harmonic measurement of normal measurement mode. A setting specific to the wide bandwidth harmonic measurement is the ON/OFF setting of the timeout warning display of the PLL lock. For these settings, see the respective sections below. The underlined sections are settings specific to the wide bandwidth harmonic measurement.

- **Selecting the wide bandwidth harmonic measurement mode** **Section 8.3**
- **Changing the number of displayed items of numeric data and scrolling the display** **Section 7.3**
- **Changing the displayed items of numeric data** **Section 7.4**
- **Selecting the PLL Source** **Section 7.5**
- **Setting the measured order** **Section 7.6**
- **Selecting the distortion factor equation** **Section 7.7**
- **Turning ON/OFF the timeout warning display of the PLL lock** **Section 8.4**
- **Setting the anti-aliasing filter** **Section 7.8**
- **Displaying the bar graph and making cursor measurements** **Section 7.9**
- **Displaying vectors** **Section 7.10**

8.3 Selecting the Wide Bandwidth Harmonic Measurement Mode and Displaying Numeric Data

Procedure

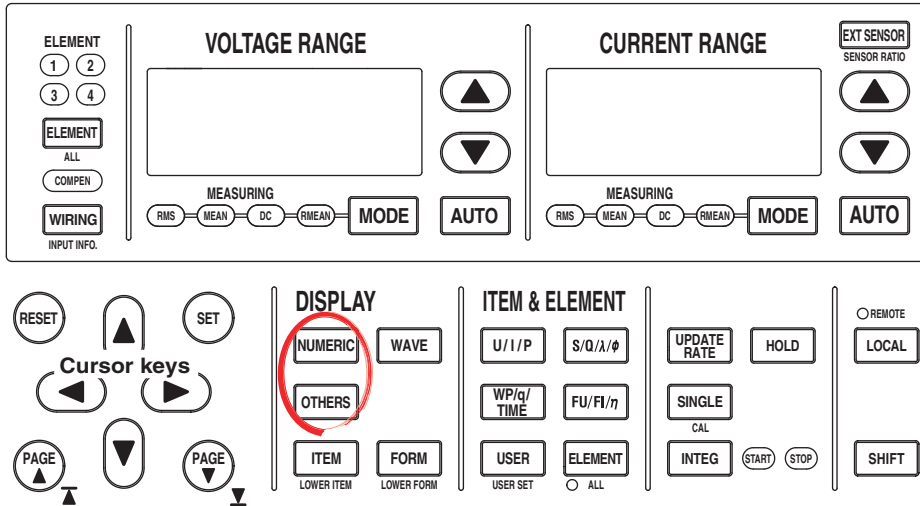

To exit the menu during operation, press **ESC** located above the soft keys.

In the procedural explanation below, the phrase “press the **cursor keys**” may be used. This phrase refers to the procedures for selecting items and entering values and character strings. For details on the procedures, see section 3.14 in the *User's Manual IM760301-01E*.

- **Displaying Numeric Data**
 1. Press **NUMERIC** to display numeric values.
- **Displaying Numeric Data on the Split Screen**
 1. Press **OTHERS** to display the Others menu.
 2. Press the **Numeric+Bar** soft key to select the display mode.

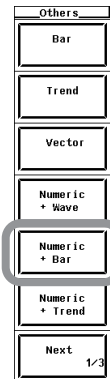

8.3 Selecting the Wide Bandwidth Harmonic Measurement Mode and Displaying Numeric Data

- **Enabling Wide Bandwidth Harmonic Measurement Mode**

If normal measurement mode is enabled, switch to wide bandwidth harmonic measurement mode.

2. Press **HRM SET** to display the Harmonics menu.
3. Press the **Freq Band** soft key to select Wide.

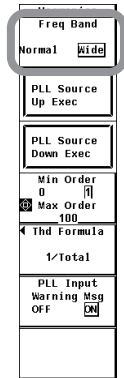

Explanation

- **Meaning of the Measurement Function Symbols**

The symbols are the same as the harmonic measurement in normal measurement mode. See section 7.2. The exceptions are the rms voltage and current. The order section is (Total), not (---). For details, see section 7.1.

- **Selecting the Display Mode and Measurement Mode**

You can select the display format of the numeric data from the list below. [-----] (no data) is displayed in places where the measurement function is not selected or where no numeric data is present.

- **Displaying the Numeric Data on the Entire Screen**

Press the NUMERIC key to display the numeric data on the entire screen.

- **Displaying Numeric Data by Dividing the Screen into Halves (Split Screen)**

- Numeric+Bar

The numeric data and bar graph are displayed separately in the top and bottom windows. For details on how to set the bar graph display, see section 7.9.

- Numeric+Wave and Numeric+Trend

Waveform and trend cannot be displayed, because there is no waveform data or trend data.

For details on selecting the measurement mode, see section 3.16 in the *User's Manual IM760301-01E*.

8.4 Turning ON/OFF the Timeout Warning Display of the PLL Lock

Procedure

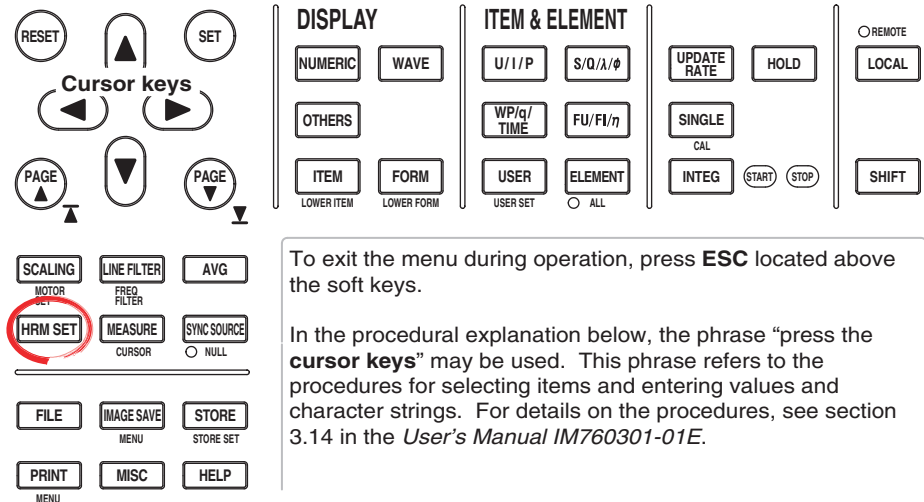

1. Press **HRM SET** to display the Harmonics menu.
2. Press the **PLL Input Warning Msg** soft key to select ON or OFF.

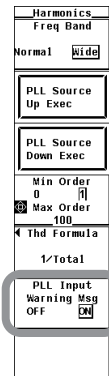

Explanation

- **Turning ON/OFF the Timeout Warning Display of the PLL Lock**
You can select whether to display a timeout warning of the PLL lock when the PLL circuit in the WT3000 cannot detect the PLL source frequency within the detection period. This function is valid only in wide bandwidth harmonic measurement mode.
 - ON: Displays the alert message.
 - OFF: Initializes the memory without displaying the alert message.
- **PLL Detection Period**
 - When the PLL source is not set to Smp Clk: 5 s
 - When the PLL source is set to Smp Clk: 40 s

8.5 Wide Bandwidth Harmonic Measurement Specifications

Item	Specifications
Measured source	All installed elements
Format	PLL synchronization method (when the PLL source is not set to Smp Clk) or external sampling clock method (when the PLL source is set to Smp Clk)
Frequency range	<ul style="list-style-type: none"> PLL synchronization method Fundamental frequency of the PLL source is in the range of 10 Hz to 2.6 kHz. External sampling clock method Input a sampling clock signal having a frequency that is 3000 times the fundamental frequency between 0.1 Hz and 66 Hz of the waveform on which to perform harmonic measurement. The input level is TTL. The input waveform is a rectangular wave with a duty ratio of 50%.
PLL source	<ul style="list-style-type: none"> Select the voltage or current of each input element (external current sensor range is greater than or equal to 500 mV) or the external clock (Ext Clk or Smp Clk). Input level Greater than or equal to 50% of the measurement range rating when the crest factor is 3 Greater than or equal to 100% of the measurement range rating when the crest factor is 6 Turn the frequency filter ON when the fundamental frequency is less than or equal to 440 Hz.
Measurement Functions	See section 7.11.
FFT data length	9000
FFT processing word length	32 bits
Window function	Rectangular
Anti-aliasing filter	Set using a line filter (OFF, 500 Hz, 5.5 kHz, or 50 kHz).
Sample rate (sampling frequency), window width, and upper limit of measured order	

PLL source synchronization method

Fundamental Frequency of the PLL Source (Hz)	Sample Rate (S/s)	Window Width against the FFT Data Length (Frequency of the Fundamental Wave)	Upper Limit of the Measured Order
10 to 20	$f \times 3000$	3	100
20 to 40	$f \times 1500$	6	100
40 to 55	$f \times 900$	10	100
55 to 75	$f \times 750$	12	100
75 to 150	$f \times 450$	20	50
150 to 440	$f \times 360$	25	50
440 to 1100	$f \times 150$	60	50
1100 to 2600	$f \times 60$	150	20

External sampling clock method

Fundamental Frequency of the PLL Source (Hz)	Sample Rate (S/s)	Window Width against the FFT Data Length (Frequency of the Fundamental Wave)	Upper Limit of the Measured Order
0.1 to 66	$f \times 3000$	3	100

Accuracy

- When the line filter (500 Hz) is ON

Frequency	Voltage and Current \pm (reading error + measurement range error)	Power \pm (reading error + measurement range error)
$0.1 \text{ Hz} \leq f < 10 \text{ Hz}$	0.7% of reading + 0.3% of range	1.4% of reading + 0.4% of range
$10 \text{ Hz} \leq f < 30 \text{ Hz}$	0.7% of reading + 0.3% of range	1.4% of reading + 0.4% of range
$30 \text{ Hz} \leq f \leq 66 \text{ Hz}$	0.7% of reading + 0.05% of range	1.4% of reading + 0.1% of range

8.5 Wide Bandwidth Harmonic Measurement Specifications

Accuracy

- When the line filter (5.5 kHz) is ON

Frequency	Voltage and Current ±(reading error + measurement range error)	Power ±(reading error + measurement range error)
0.1 Hz ≤ f < 10 Hz	0.25% of reading + 0.3% of range	0.5% of reading + 0.4% of range
10 Hz ≤ f < 30 Hz	0.25% of reading + 0.3% of range	0.5% of reading + 0.4% of range
30 Hz ≤ f ≤ 66 Hz	0.3% of reading + 0.05% of range	0.45% of reading + 0.1% of range
66 Hz < f ≤ 440 Hz	0.6% of reading + 0.05% of range	1.2% of reading + 0.1% of range
440 Hz < f ≤ 1 kHz	1% of reading + 0.05% of range	2% of reading + 0.1% of range
1 kHz < f ≤ 2.5 kHz	2.5% of reading + 0.05% of range	5% of reading + 0.15% of range
2.5 kHz < f ≤ 3.5 kHz	8% of reading + 0.05% of range	16% of reading + 0.15% of range

If the fundamental frequency is between 1 kHz and 2.6 kHz

Add 0.5% of reading to the voltage and current accuracy for frequencies greater than 1 kHz.

Add 1% of reading to the power accuracy for frequencies greater than 1 kHz.

- When the line filter (50 kHz) is ON

Frequency	Voltage and Current ±(reading error + measurement range error)	Power ±(reading error + measurement range error)
0.1 Hz ≤ f < 10 Hz	0.25% of reading + 0.3% of range	0.45% of reading + 0.4% of range
10 Hz ≤ f < 30 Hz	0.25% of reading + 0.3% of range	0.45% of reading + 0.4% of range
30 Hz ≤ f ≤ 440 Hz	0.3% of reading + 0.05% of range	0.45% of reading + 0.1% of range
440 Hz < f ≤ 1 kHz	0.7% of reading + 0.05% of range	1.4% of reading + 0.1% of range
1 kHz < f ≤ 5 kHz	0.7% of reading + 0.05% of range	1.4% of reading + 0.15% of range
5 kHz < f ≤ 10 kHz	3.0% of reading + 0.05% of range	6% of reading + 0.15% of range

If the fundamental frequency is between 1 kHz and 2.6 kHz

Add 0.5% of reading to the voltage and current accuracy for frequencies greater than 1 kHz.

Add 1% of reading to the power accuracy for frequencies greater than 1 kHz.

- When the line filter is OFF

Frequency	Voltage and Current ±(reading error + measurement range error)	Power ±(reading error + measurement range error)
0.1 Hz ≤ f < 10 Hz	0.15% of reading + 0.3% of range	0.25% of reading + 0.4% of range
10 Hz ≤ f < 30 Hz	0.15% of reading + 0.3% of range	0.25% of reading + 0.4% of range
30 Hz ≤ f ≤ 1 kHz	0.1% of reading + 0.05% of range	0.2% of reading + 0.1% of range
1 kHz < f ≤ 10 kHz	0.3% of reading + 0.05% of range	0.6% of reading + 0.15% of range
10 kHz < f ≤ 55 kHz	1% of reading + 0.2% of range	2% of reading + 0.4% of range

- If the fundamental frequency is between 400 Hz and 1 kHz

Add 1.5% of reading to the voltage and current accuracy for frequencies greater than 10 kHz.

Add 3% of reading to the power accuracy for frequencies greater than 10 kHz.

- If the fundamental frequency is between 1 kHz and 2.6 kHz

Add 0.5% of reading to the voltage and current accuracy for frequencies greater than 1 kHz and less than or equal to 10 kHz.

Add 7% of reading to the voltage and current accuracy for frequencies greater than 10 kHz.

Add 1% of reading to the power accuracy for frequencies greater than 1 kHz and less than equal to 10 kHz.

Add 14% of reading to the power accuracy for frequencies greater than 10 kHz.

However, all the items below apply to all tables.

- When the crest factor is set to 3
- When λ (power factor) = 1
- Power figures that exceed 440 Hz are reference values.
- For external current sensor range, add 0.2 mV to the current accuracy and add (0.2 mV/external current sensor range rating)×100% of range to the power accuracy.
- For direct current input range on the 30-A input element, add 0.2 mA to the current accuracy and add (0.2 mA/direct current input range rating)×100% of range to the power accuracy.
- For direct current input range on the 2-A input element, add 2 μ A to the current accuracy and add (2 μ A/direct current input range rating)×100% of range to the power accuracy.
- For n^{th} order component input, add $\{(n/(m+1))/50\}$ % of (the n^{th} order reading) to the $n+m^{\text{th}}$ order and $n-m^{\text{th}}$ order of the voltage and current, and add $\{(n/(m+1))/25\}$ % of (the n^{th} order reading) to the $n+m^{\text{th}}$ order and $n-m^{\text{th}}$ order of the power.
- Add (n/500)% of reading to the n^{th} component of the voltage and current, and add (n/250)% of reading to the n^{th} component of the power.

8.5 Wide Bandwidth Harmonic Measurement Specifications

- Accuracy when the crest factor is 6: The same as when the range is doubled for crest factor 3.
- The accuracy guaranteed range by frequency and voltage/current is the same as the guaranteed range of normal measurement.

Frequency Measurement

Item	Specifications
Measurement range	<ul style="list-style-type: none">• PLL synchronization method: $2.5 \text{ Hz} \leq f \leq 100 \text{ kHz}$• External sampling clock method: $0.15 \text{ Hz} \leq f \leq 5 \text{ kHz}$

Measurement Function

Item	Specifications
Display update	<p>Depends on the PLL source</p> <ul style="list-style-type: none">• PLL synchronization method: 1 s or more• External sampling clock method: 20 s or more

PLL Lock Timeout Warning

Item	Specifications
Timeout value	<p>Depends on the PLL source</p> <ul style="list-style-type: none">• PLL synchronization method: 5 s or more• External sampling clock method: 40 s or more

Functional Limitations

Item	Specifications
Display	Waveform display, trend display, computed waveform display, and FFT display are not allowed.
Averaging	Moving average is not allowed.
Data update rate	Depends on the PLL source
Voltage/Current mode	Not selectable. The LED is OFF.
Peak measurement	Not allowed
Efficiency computation	Not allowed
Compensation	Efficiency compensation is invalid.
Integration	Not allowed
Store	Integration synchronization (Integ Sync) is not allowed. Waveform storage is not allowed.
File save	Waveform and waveform sampling data (Acquisition) are not allowed
NULL	Not allowed
Synchronized measurement	Not allowed
Motor evaluation function	Not allowed
Print	Integration synchronization using auto print is not allowed.
Delta computation	Not allowed

Measurement Functions

For a description of the measurement functions of wide bandwidth harmonic measurement mode and how they are determined, see section 7.11. Measurement is not allowed for measurement functions related to the functions above that have limitations. For a list of measurement functions that cannot be measured, see appendices 10 and 11 in the *User's Manual IM760301-01E*.

9.1 IEC Harmonic Measurement Function

This mode in combination with the Harmonic/Flicker Measurement Software sold separately allows you to perform harmonic measurement conforming to IEC61000-3-2. Use this mode to check that the harmonics of electric home appliances and office automation equipment comply with the IEC standards.

- **Connecting to the Harmonic/Flicker Measurement Software**

For details on connecting the WT3000 to the Harmonic/Flicker Measurement Software, see the user's manual of the Harmonic/Flicker Measurement Software.

When you use the Harmonic/Flicker Measurement Software, the WT3000 enters remote mode in which key operations on the WT3000 are disabled. The settings described in the subsequent sections are set automatically or set from the setup screen of the software.

Note

Do not release the remote mode of the WT3000 and change the settings while operating the WT3000 with the Harmonic/Flicker Measurement Software. Doing so may impede harmonic measurements conforming to the IEC standard. If you release the remote mode of the WT3000, close the Harmonic/Flicker Measurement Software.

- **Limitations on the Function and Measurement Function**

IEC harmonic measurement mode performs internal computation differently from other measurement modes in order to achieve measurements conforming to the IEC standard. Therefore, some functions such as waveform or bar graph display on the screen, store function, motor evaluation function (motor version) cannot be used in this measurement mode. In addition, some measurement functions such as peak measurement, integration, and efficiency computation cannot be carried out. For a list of functions with limitations and measurement functions that cannot be measured, see appendix 10 and 11 in the *User's Manual IM760301-01E*.

- **Differences from Other Harmonic Measurement Modes**

For the differences from the harmonic measurement in normal measurement mode and wide bandwidth harmonic measurement mode, see "Harmonic Measurement Types" in section 7.1.

- **Voltage/Current Mode and Measured Values of Voltage U and Current I**

The voltage/current mode settings are invalid in IEC harmonic measurement mode. The voltage/current mode LED turns OFF. The voltage U and current I values that are measured in this measurement mode are total values. For details on the total value, see "Relationship between the Rms Values of Voltage U/Current I and Measurement Modes" in section 7.1.

- **Description of Other Functions Related to Harmonic Measurement**

For a functional description of the items below, see section 7.1.

- Types of harmonic measurement functions
- Measurement period of harmonic measurement functions
- Numeric display related to harmonic measurement
- Equation for distortion factor

9.1 IEC Harmonic Measurement Function

In IEC harmonic measurement, the WT3000 performs Fourier transform on the input signal and divides the signal into frequency components as follows:

- **Interharmonics**

If the input signal is 50 Hz, 10 periods of the waveform are divided in 5-Hz resolution. Thus, the section between each harmonic order is divided into 10 sections. The components between each harmonic order are called interharmonics.

When the fundamental signal is 50 Hz

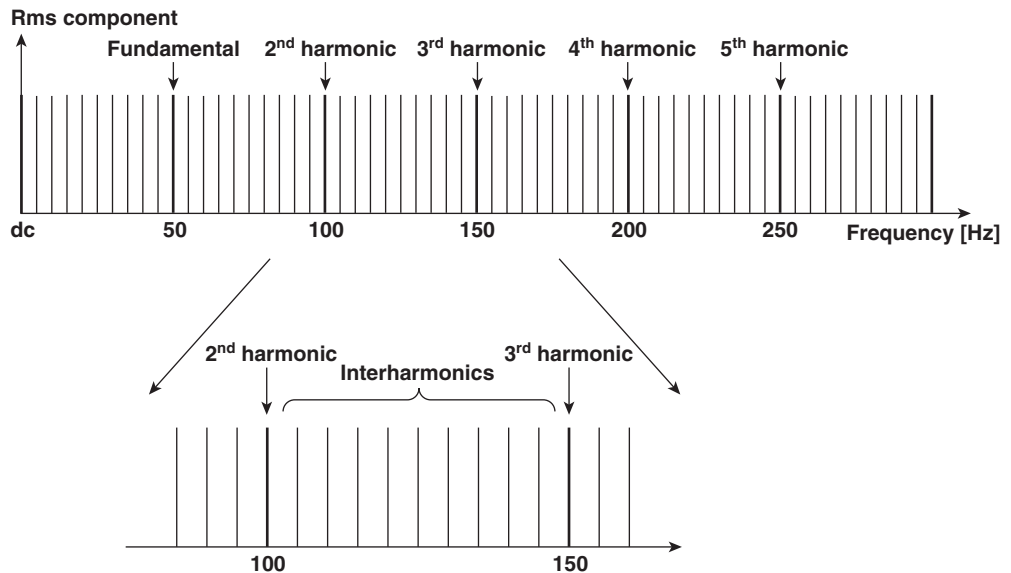

If the input signal is 60 Hz, 12 periods of the waveform are divided in 5-Hz resolution. Thus, the section between each harmonic order is divided into 12 sections.

When the fundamental signal is 60 Hz

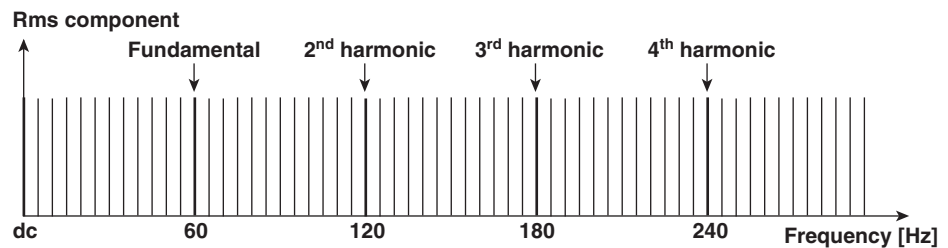

- **Harmonic Subgroup**

A harmonic and its two directly adjacent interharmonics are collectively called harmonic subgroup. The computing method to combine the harmonic and its two adjacent interharmonics is not simple addition, but the square root of the sum of the square of each component.

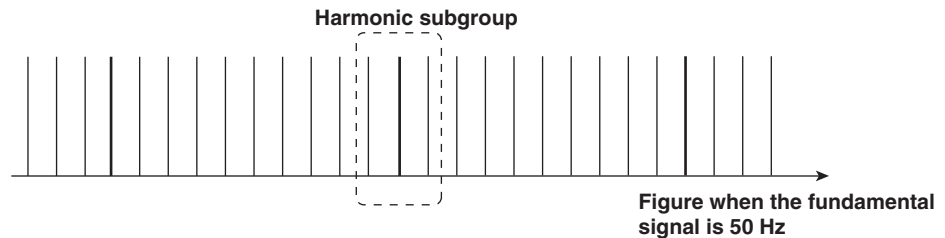

- **Harmonic Group**

A harmonic and its adjacent interharmonics are collectively called harmonic subgroup. The computing method to combine the components is the average of the sum of the squares as with the harmonic subgroup. A half of the amplitude is included for the interharmonic that is in the middle of two orders.

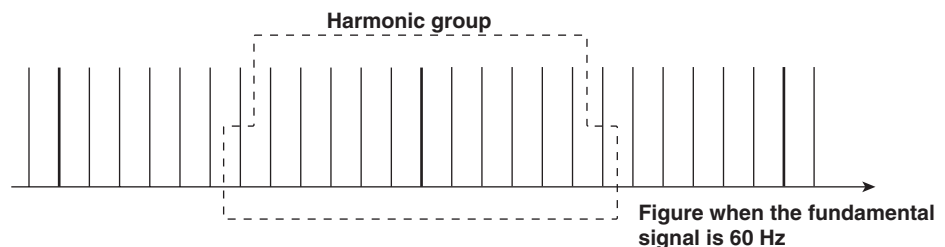
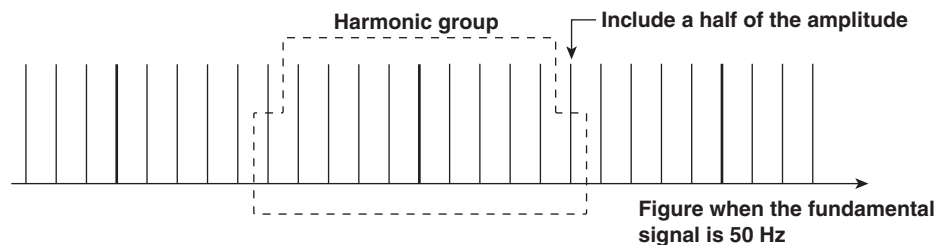

- **Grouping of Harmonics in IEC Harmonic Measurement**

There are three types of grouping of harmonics in IEC harmonic measurement. The method to calculate the amplitude of the rms value of the harmonics varies depending on the grouping method.

- **No Grouping (OFF)**

Only the components of the integer multiples of the fundamental wave are considered harmonics. Therefore, interharmonic components are not included.

- **Grouping Type 1**

The harmonic subgroup is considered a component of the corresponding order. Therefore, harmonics take on a larger value when harmonic subgroups are included in the input signal as compared to when grouping is turned OFF.

- **Grouping Type 2**

The harmonic group is considered a component of the corresponding order. Therefore, harmonics take on a larger value when harmonic groups are included in the input signal as compared to when grouping is turned OFF.

9.1 IEC Harmonic Measurement Function

- **Example of Grouping Type 2**

For example, the 3rd order (150-Hz) harmonic component of the 50-Hz input signal is determined by averaging the sum of the squares of the following frequency components.

- 1/2 of the 125-Hz component The other 1/2 is included in the 2nd order (100-Hz) component.
- 130-Hz component
- 135-Hz component
- 140-Hz component
- 145-Hz component
- 150-Hz component 3rd order harmonic
- 155-Hz component
- 160-Hz component
- 165-Hz component
- 170-Hz component
- 1/2 of the 175-Hz component The other 1/2 is included in the 4th order (200-Hz) component.

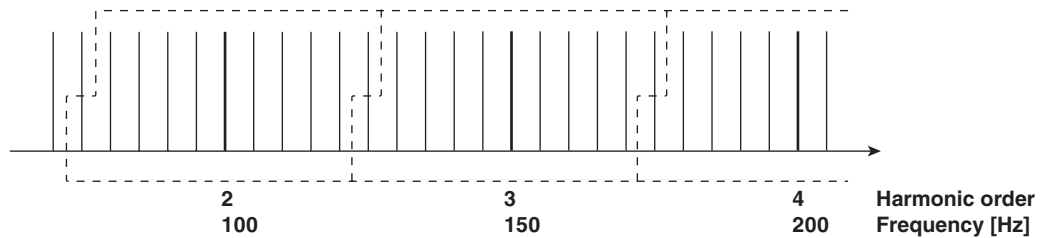

The component of each order between the 2nd and 50th order is determined as shown above. The computation of the 1st order (fundamental) component differs from the method shown above.

- **1st Order (Fundamental) Component**

When measuring and computing the 1st order (fundamental) component, interharmonics are not included regardless of the grouping setting.

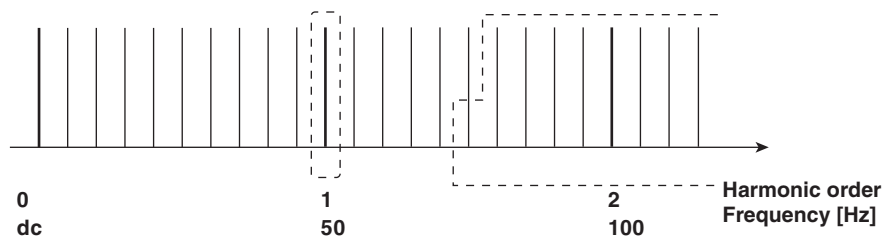

In other words, components such as 40 Hz, 45 Hz, 55 Hz, and 60 Hz are not included in the 1st order (fundamental) component. However, the interharmonic components are included in the 1st order (fundamental) component according to the grouping setting when computing the harmonic distortion.

9.2 Various Settings Related to IEC Harmonic Measurement

To set the IEC harmonic measurement, use the Harmonic/Flicker Measurement Software or set the WT3000 according to the procedures in the respective section below before switching the WT3000 to remote mode using the Harmonic/Flicker Measurement Software. The underlined sections are settings specific to the IEC harmonic measurement.

- **Selecting the IEC harmonic measurement mode** **Section 9.3**

If you use the Harmonic/Flicker Measurement Software, the WT3000 automatically switches to IEC harmonic measurement mode.

- **Changing the number of displayed items of numeric data and scrolling the display** **Section 7.3**
- **Changing the displayed items of numeric data** **Section 7.4**
- **Selecting the measured source** **Section 9.4**

- **Selecting the PLL Source** **Section 7.5**
- **Setting the measured order** **Section 7.6**
 - The maximum order in IEC harmonic measurement mode is 50. Orders exceeding 50 cannot be measured even if you specify such orders.
 - If you use the Harmonic/Flicker Measurement Software, the maximum order is automatically set to 40.

- **Selecting the distortion factor equation** **Section 7.7**
- **Selecting the voltage/current grouping** **Section 9.5**

Note

Do not release the remote mode of the WT3000 and change the settings while operating the WT3000 with the Harmonic/Flicker Measurement Software. Doing so may impede harmonic measurements conforming to the IEC standard. If you release the remote mode of the WT3000, close the Harmonic/Flicker Measurement Software.

9.3 Selecting the IEC Harmonic Measurement Mode

Procedure

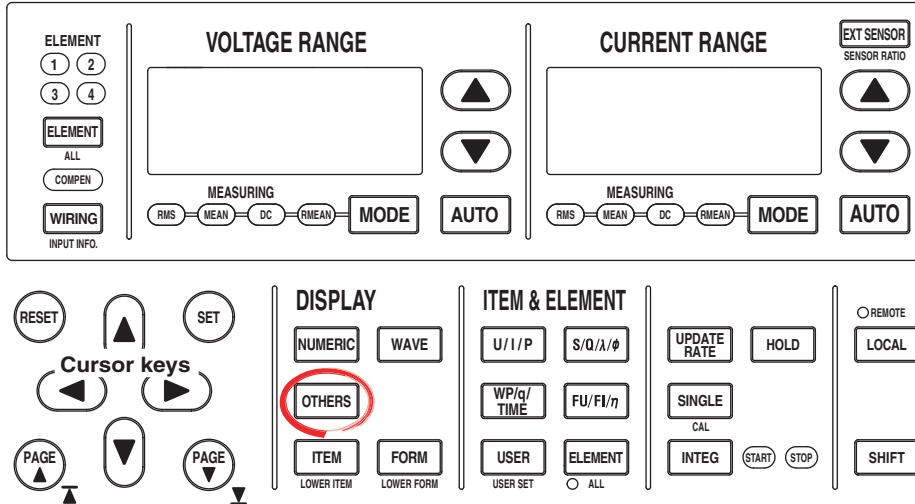

To exit the menu during operation, press **ESC** located above the soft keys.

In the procedural explanation below, the phrase “press the **cursor keys**” may be used. This phrase refers to the procedures for selecting items and entering values and character strings. For details on the procedures, see section 3.14 in the *User's Manual IM760301-01E*.

• Enabling IEC Harmonic Measurement Mode

1. Press **OTHERS** to display the Others menu.
2. Press the **IEC Harmonics** soft key.

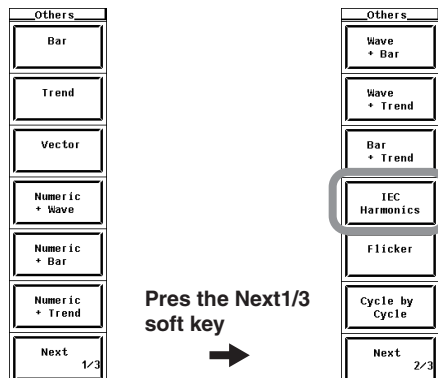

Explanation

If you use the Harmonic/Flicker Measurement Software, the WT3000 automatically switches to IEC harmonic measurement mode.

The WT3000 cannot switch to IEC harmonic measurement mode in the following conditions.

- When the master/slave synchronization measurement is set to slave.
- When the integration is started or stopped.
- When auto print is ON.
- While storage or recall operation is in progress.
- While the storage medium is being accessed.
- While saving waveform sampling data to the storage medium.

9.4 Selecting the Measured Source

Procedure

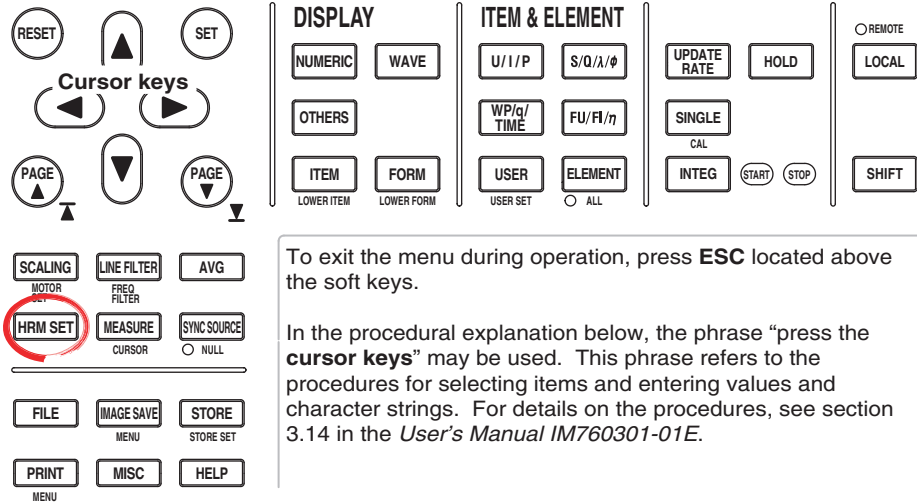

1. Press **HRM SET** to display the IEC Harmonics menu.
2. Press the **Object** soft key to display the element/wiring unit selection box.
3. Press the **cursor keys** to select any of the elements/wiring units starting with Element1.
4. Press **SET**. The symbol for the selected element number or wiring unit and the numeric data are displayed at the highlighted position.

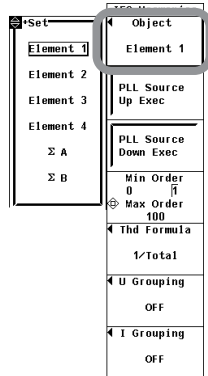

Explanation

- **Selecting the Measured Source**
 - You can select the measured source from the following elements/wiring units. The selectable items vary depending on the installed elements. Element1, Element2, Element3, Element4, ΣA , and ΣB
 - If there are no elements that are assigned to the selected wiring unit, there is no numeric data. Thus, [-----] (no data) is displayed in this case. For example, if elements are assigned to ΣA and no elements are assigned to ΣB , then the measurement function for ΣB shows [-----] (no data).

9.5 Selecting the Voltage/Current Grouping

Procedure

To exit the menu during operation, press **ESC** located above the soft keys.

In the procedural explanation below, the phrase “press the **cursor keys**” may be used. This phrase refers to the procedures for selecting items and entering values and character strings. For details on the procedures, see section 3.14 in the *User's Manual IM760301-01E*.

1. Press **HRM SET** to display the IEC Harmonics menu.
- **Selecting the Voltage Grouping**
 2. Press the **U Grouping** soft key to display the U Grouping menu.
 3. Press any of the soft keys from **OFF**, **Type 1**, and **Type 2** to select the voltage grouping.

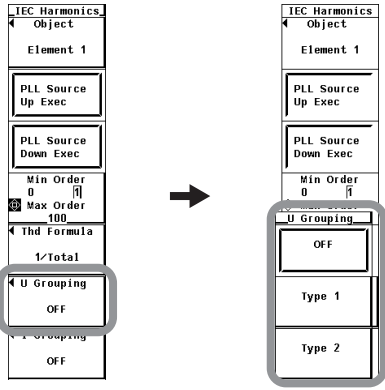

- **Selecting the Current Grouping**
 2. Press the **I Grouping** soft key to display the I Grouping menu.
 3. Press any of the soft keys from **OFF**, **Type 1**, and **Type 2** to select the current grouping.

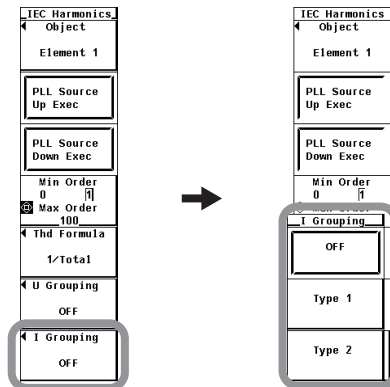

Explanation

- **Selecting the Voltage/Current Grouping**

The harmonics in IEC harmonic measurement are determined from the component of each order and the interharmonics between the orders. You can select the computing equation of the harmonic from the list below.

 - **OFF**

Only the components of the integer multiples of the fundamental wave are considered harmonic component of each order. Interharmonic components are not included.
 - **Type1**

The harmonic subgroup is considered a harmonic component of the corresponding order.
 - **Type2**

The harmonic group is considered a harmonic component of the corresponding order.

9.6 IEC Harmonic Measurement Specifications

Item	Specifications
Measured source	Select an input element or an Σ wiring unit
Format	PLL synchronization method
Frequency range	Fundamental frequency of the PLL source is in the range of 45 Hz to 66 Hz.
PLL source	<ul style="list-style-type: none"> Select the voltage or current of each input element (external current sensor range is greater than or equal to 500 mV) or the external clock (fundamental frequency). Input level Greater than or equal to 50% of the measurement range rating when the crest factor is 3 Greater than or equal to 100% of the measurement range rating when the crest factor is 6 Be sure to turn the frequency filter ON.
Measurement Functions	See section 7.11.
FFT data length	9000
FFT processing word length	32 bits
Window function	Rectangular
Anti-aliasing filter	Set using a line filter (5.5 kHz).
Interharmonic measurement	Grouping function Enable (Type 1 or Type 2)/Disable (OFF)
Sample rate (sampling frequency), window width, and upper limit of measured order	

Fundamental Frequency of the PLL Source (Hz)	Sample Rate (S/s)	Window Width against the FFT Data Length (Frequency of the Fundamental Wave)	Upper Limit of the Measured Order
45 to 55	$f \times 900$	10	50
55 to 66	$f \times 750$	12	50

Accuracy

- When the line filter (5.5 kHz) is ON

Frequency	Voltage and Current ±(reading error + measurement range error)	Power ±(reading error + measurement range error)
45 Hz ≤ f ≤ 66 Hz	0.2% of reading + 0.04% of range	0.4% of reading + 0.05% of range
66 Hz < f ≤ 440 Hz	0.5% of reading + 0.05% of range	1.2% of reading + 0.1% of range
440 Hz < f ≤ 1 kHz	1% of reading + 0.05% of range	2% of reading + 0.1% of range
1 kHz < f ≤ 2.5 kHz	2.5% of reading + 0.05% of range	5% of reading + 0.15% of range
2.5 kHz < f ≤ 3.3 kHz	8% of reading + 0.05% of range	16% of reading + 0.15% of range

However, all the items below apply.

- When the crest factor is set to 3
- When λ (power factor) = 1
- Power figures that exceed 440 Hz are reference values.
- For external current sensor range, add 0.03 mV to the current accuracy and add (0.03 mV/external current sensor range rating)×100% of range to the power accuracy.
- For direct current input range on the 30-A input element, add (0.1 mA/direct current input range rating)×100% of range to the power accuracy.
- For direct current input range on the 2-A input element, add (1 μA/direct current input range rating)×100% of range to the power accuracy.
- For direct current input in a range less than or equal to 200-mA on the 2-A input element, add 0.02% of reading + 0.01% of range to the current accuracy in the range of 45 Hz ≤ f ≤ 66 Hz and add 0.03% of reading + 0.01% of range to the power accuracy.
- For nth order component input, add (n/(m+1))/50% of (the nth order reading) to the n+mth order and n-mth order of the voltage and current, and add (n/(m+1))/25% of (the nth order reading) to the n+mth order and n-mth order of the power (only when applying a single frequency).
- Accuracy when the crest factor is 6: The same as when the range is doubled for crest factor 3.
- The accuracy guaranteed range by frequency and voltage/current is the same as the guaranteed range of normal measurement.

9.6 IEC Harmonic Measurement Specifications

Frequency Measurement

Item	Specifications
Measurement range	45 Hz ≤ f ≤ 1 MHz

Measurement Function

Item	Specifications
Display update	Depends on the PLL source (Approximately 200 ms when the frequency of the PLL source is 45 Hz to 66 Hz.)

Functional Limitations

Item	Specifications
Display	Waveform display, trend display, bar graph display, vector display, waveform computation display, and FFT display are not allowed.
Auto range	Not allowed
Averaging	Moving average is not allowed. Only exponential averaging is available, and the attenuation constant is fixed to the value as defined by the IEC standard.
Data update rate	Depends on the PLL source
Voltage/Current mode	Not selectable. The LED is OFF.
Peak measurement	Not allowed
User-defined function	Not allowed
MAX hold	Not allowed
Efficiency computation	Not allowed
Compensation	Efficiency compensation is invalid.
Integration	Not allowed
Store	Not allowed
File save	Waveform and waveform sampling data (Acquisition) are not allowed
NULL	Not allowed
Synchronized measurement	Not allowed
Motor evaluation function	Not allowed
Print	Auto print is not allowed.
Delta computation	Not allowed
E-mail transmission	Not allowed

Measurement Functions

For a description of the measurement functions of IEC harmonic measurement mode and how they are determined, see section 7.11.

Measurement is not allowed for measurement functions related to the functions above that have limitations. For a list of measurement functions that cannot be measured, see appendices 10 and 11 in the *User's Manual IM760301-01E*.

Determination of Measurement Functions Related to the IEC Harmonic Measurement

Measurement Function	Method of Determination, Equation	
	When the frequency of the measured item is 50 Hz	When the frequency of the measured item is 60 Hz
Rms value of the harmonic subgroup of the voltage $U(k)$ [V]	$\sqrt{\sum_{i=-1}^1 U(k+i)^2}$	
Rms value of the harmonic subgroup of the current $I(k)$ [A]	$\sqrt{\sum_{i=-1}^1 I(k+i)^2}$	
Rms value of the harmonic group of the voltage $U(k)$ [V]	$\sqrt{\frac{U(k-5)^2}{2} + \sum_{i=-4}^4 U(k+i)^2 + \frac{U(k+5)^2}{2}}$	$\sqrt{\frac{U(k-6)^2}{2} + \sum_{i=-5}^5 U(k+i)^2 + \frac{U(k+6)^2}{2}}$
Rms value of the harmonic group of the current $I(k)$ [A]	$\sqrt{\frac{I(k-5)^2}{2} + \sum_{i=-4}^4 I(k+i)^2 + \frac{I(k+5)^2}{2}}$	$\sqrt{\frac{I(k-6)^2}{2} + \sum_{i=-5}^5 I(k+i)^2 + \frac{I(k+6)^2}{2}}$

10.1 Waveform Computation Function

Waveforms obtained by adding/subtracting displayed waveforms or squared or averaged waveforms can be displayed. For example, this allows the waveform of instantaneous power to be displayed by multiplying the voltage waveform by the current waveform. In addition, a cursor can be placed on the waveform to display various data at that point.

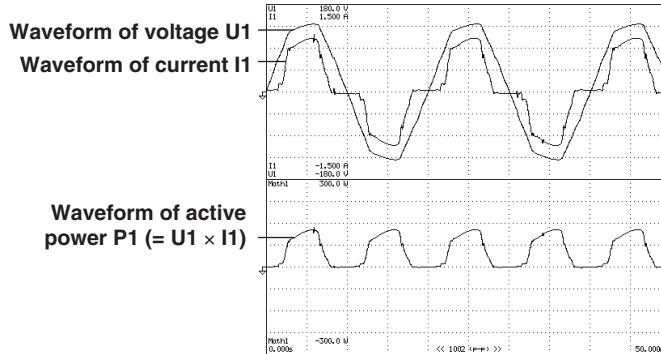

• **Equation**

Two equations (Math1 and Math2) can be created by using operands U1 to I4, TORQUE, and SPEED that correspond to the input signals of each input element and motor input. In addition, operands P1 (which is equal to U1×I1) and Pm (which is equal to TORQUE×SPEED) can be used. There can be up to 16 operands in an equation. The following operators are available: +, -, *, /, ABS (absolute value), SQR (square), SQRT (square root), LOG (natural logarithm), LOG10 (common logarithm), EXP (exponent), NEG (negation), and AVG2 to AVG64 (exponential average). The computed results are displayed as computed waveforms (Math1 and Math2).

• **AVG**

The rms voltage or current or the instantaneous value (sampled data) of the active power can be exponentially averaged using a specified attenuation constant, and the waveform can be displayed. Averaging is performed according to the following equation.

$$X_n = X_{n-1} + \frac{(d_n - X_{n-1})}{k}$$

- x_n: nth display data (The first display data x₁ is d₁.)
- x_{n-1}: n-1th display data that has been exponentially averaged
- d_n: nth sampled data
- k: Attenuation constant (select from 2, 4, 8, 16, 32, and 64)

Example of How to Write the AVG Function

AVG64(P1): Displays the AVG waveform of the active power of element 1.

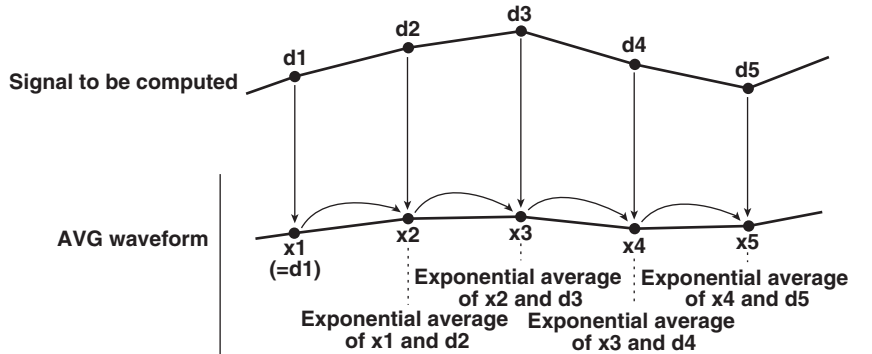

- **Equation Examples**

- **Instantaneous Power Waveform**

To multiply the voltage waveform by the current waveform of input element 1 and display the instantaneous power waveform, set the equation to P1.

- **Voltage and Current Waveforms of a Three-Phase, Three-Wire System**

To display the voltage between the phases R and S and the current of phase T of a three-phase, three-wire system when there are only two input elements, set the equations as follows:

Math1: U1-U2

Voltage between phases R and S = (voltage between phases R and T) - (voltage between phases S and T)

Math2: -(I1+I2)

Current of phase T = -(current of phase R + current of phase S)

- **Current Waveform of the Neutral Line of a Three-Phase, Four-Wire System**

To display the current waveform of the neutral line of a three-phase, four-wire system when there are only three input elements, set the equation as follows:

Math1: -(I1+I2+I3)

Current of the neutral line = -(current of phase R + current of phase S + current of phase T)

- **Instantaneous Waveform of Motor Output (Mechanical Power)**

To multiply the motor's torque signal by the speed signal and display the instantaneous waveform of the motor output, set the equation to Pmi.

- **Eliminating the Noise from the Computed Waveform**

Use averaging (AVG) to eliminate high frequency components from the computed waveform. The noise elimination effect is higher as the attenuation constant is increased. However, the response delay also increases as compared to when averaging is not used.

- **Limitations on the Function and Measurement Function**

Waveform computation mode performs internal computation differently from other measurement modes. Therefore, some functions such as trend and bar graph displays on the screen, integration, and storage function cannot be used in this measurement mode. In addition, some measurement functions such as harmonic measurement and impedance cannot be carried out. For a list of functions with limitations and measurement functions that cannot be measured, see appendix 10 and 11 in the *User's Manual IM760301-01E*.

Note

In waveform computation mode, TYPE 3 cannot be selected for the equation of the apparent or reactive power. If TYPE3 is selected and you select waveform computation mode, the equation switches to TYPE1. For details on the type of equations, see section 2.5 and 5.9 in the *User's Manual IM760301-01E*.

- **Rms Values of Voltage U and Current I**

The rms values of the voltage U and current I that are measured in the waveform computation mode are normal measured values. For details on the normal measured value, see "Relationship between the Rms Values of Voltage U/Current I and Measurement Modes" in section 7.1.

10.2 Various Settings Related to Waveform Computation

A portion of the settings related to waveform computation is common with the “waveform display in normal measurement mode” and “FFT mode.” The settings described in sections 10.3 to 10.5 are those specific to waveform computation. Set these items first.

- **Selecting the waveform computation mode** **Section 10.3**
- **Setting the waveform equation** **Section 10.4**
- **Setting the scale, unit, and label of the computed waveform** **Section 10.5**

The settings below are common with the waveform display of normal measurement mode. See the respective sections below in the *User's Manual IM760301-01E*.

- **Selecting the waveform to be displayed** **Section 6.2**
- **Setting the time axis** **Section 6.3**
- **Setting the trigger** **Section 6.4**
- **Zooming vertically and moving the vertical position** **Section 6.5**
- **Waveform display on divided windows** **Section 6.6**
- **Selecting the display interpolation and graticule** **Section 6.7**
- **Turning ON/OFF the scale value and waveform label** **Section 6.8**
- **Cursor measurement** **Section 6.9**

If you change settings that are common with the “waveform display in normal measurement mode” and “FFT mode” in waveform computation mode, the waveform display settings in normal measurement mode and FFT mode are also changed. For example, if you change the time axis to 20 ms/division in waveform computation mode, the time axis of the waveform display in normal measurement mode is also changed to 20 ms/division.

10.3 Setting the Waveform Computation Mode

Procedure

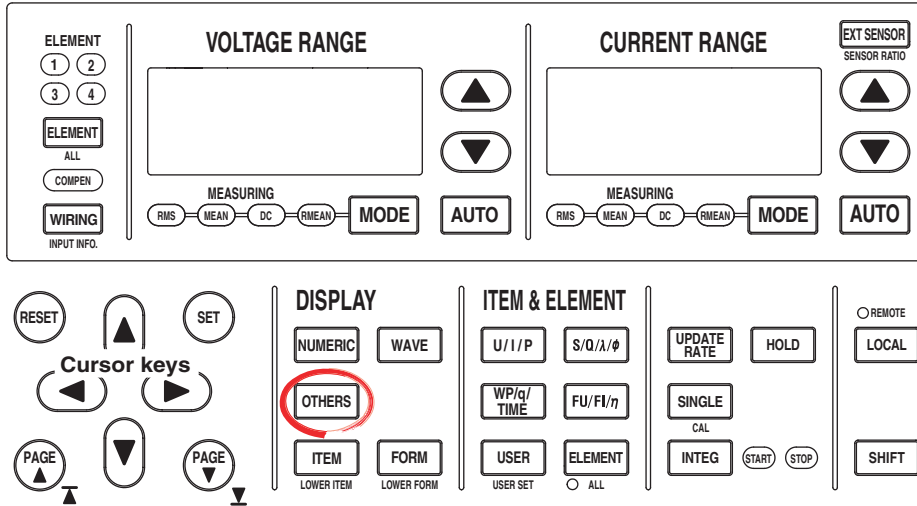

To exit the menu during operation, press **ESC** located above the soft keys.

In the procedural explanation below, the phrase “press the **cursor keys**” may be used. This phrase refers to the procedures for selecting items and entering values and character strings. For details on the procedures, see section 3.14 in the *User's Manual IM760301-01E*.

- **Enabling Waveform Computation Mode**
 1. Press **OTHERS** to display the Others menu.
 2. Press the **Math** or **Numeric+Math** soft key.

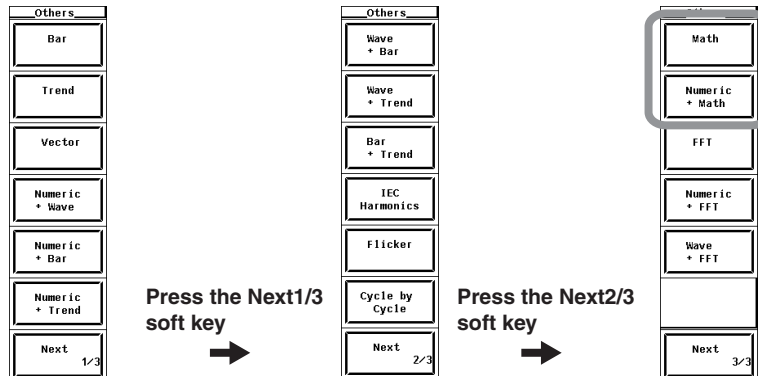

Explanation

You can select the display format of the waveform computation data from the list below.

- Display the waveform computation data on the entire screen.
If you select **Math**, the waveform computation data is displayed on the entire screen.
- Displaying waveform computation data by dividing the screen into halves (split screen)
If you select **Numeric+Math**, the numeric data and waveform computation data are displayed separately in the top and bottom windows.

10.4 Setting the Waveform Equation

Procedure

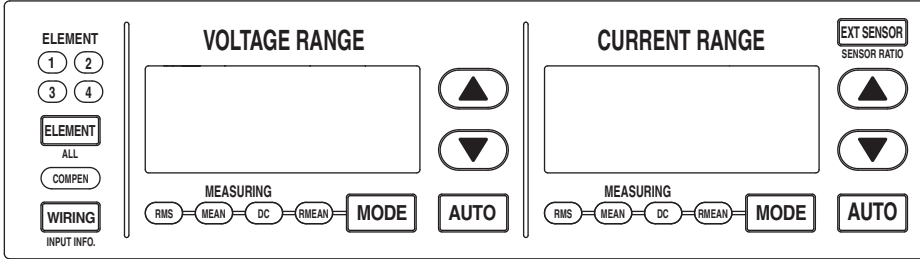

To exit the menu during operation, press **ESC** located above the soft keys.

In the procedural explanation below, the phrase “press the **cursor keys**” may be used. This phrase refers to the procedures for selecting items and entering values and character strings. For details on the procedures, see section 3.14 in the *User's Manual IM760301-01E*.

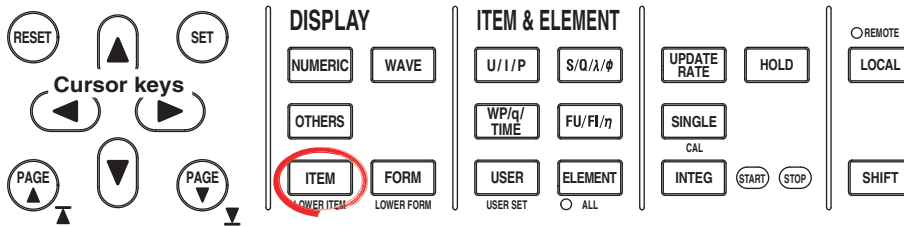

1. Press **ITEM** to display the Wave/Math Items menu.
If the waveform computation display is at the lower section of the screen on the split display, press **SHIFT+ITEM (LOWER ITEM)**.
2. Press the **Math Setup** soft key to display the Math Setup dialog box.

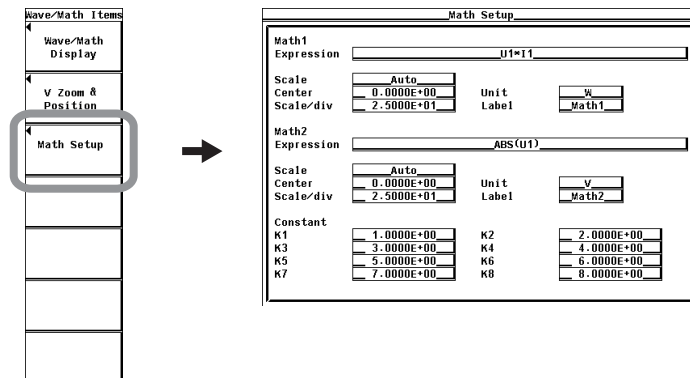

10.4 Setting the Waveform Equation

- **Setting the Computing Equation**

3. Press the **cursor keys** to select Expression of Math1 or Math2.
4. Press **SET** to display the keyboard.
5. Use the **keyboard** to set the equation.

For keyboard operations, see section 3.14 in the *User's Manual IM760301-01E*.

Display example when Expression of Math1 is selected

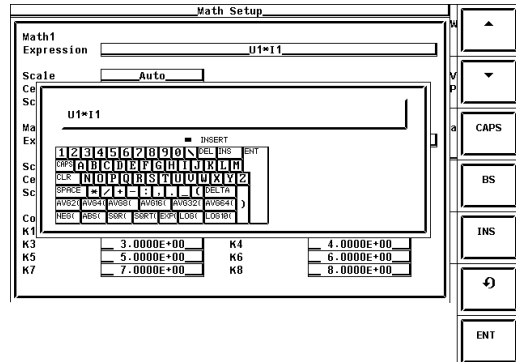

- **Setting the Constant**

3. Press the **cursor keys** to select any of the K1 to K8 constants.
4. Press **SET** to display the constant setup box.
5. Press the **cursor keys** to set the constant.

Display example when K1 is selected

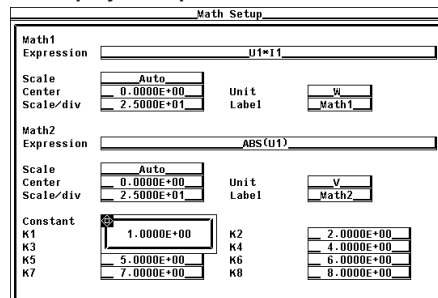

Explanation

You can create two equations (Math1 and Math2).

- **Setting the Equation**

- **Operand**

The following operands can be combined to create an equation. There can be up to 16 operands in an equation.

Operand	Description
U1 to U4	Voltage waveform of each input element
I1 to I4	Current waveform of each input element
P1 to P4	Voltage waveform × current waveform of each input element (instantaneous power waveform)
TORQUE	Torque signal waveform of the motor input
SPEED	Speed signal waveform of the motor input
Pmi	TORQUE × SPEED (instantaneous waveform of motor output)
K1 to K8	Constant

- **Operator**

The following operators can be combined to create an equation.

Operator	Setting Example	Description
+, -, *, /	U1+I1	Four arithmetic operation of the specified waveform.
ABS	ABS(U1)	Absolute value of the specified waveform
SQR	SQR(U1)	Square of the specified waveform
SQRT	SQRT(U1)	Square root of the specified waveform
LOG	LOG(U1)	Natural logarithm of the specified waveform
LOG10	LOG10(U1)	Common logarithm of the specified waveform
EXP	EXP(U1)	Exponent of the specified waveform
NEG	NEG(U1)	Negation of the specified waveform
AVG2	AVG2(U1*I1)	Average of the specified waveform with an average constant of 2
AVG4	AVG4(U1*I1)	Average of the specified waveform with an average constant of 4
AVG8	AVG8(U1*I1)	Average of the specified waveform with an average constant of 8
AVG16	AVG16(U1*I1)	Average of the specified waveform with an average constant of 16
AVG32	AVG32(U1*I1)	Average of the specified waveform with an average constant of 32
AVG64	AVG64(U1*I1)	Average of the specified waveform with an average constant of 64

- **Number and Type of Characters That Can Be Used in the Equation**

- **Number of Characters**

50 characters or less

- **Types of Characters**

Characters that are displayed on the keyboard and spaces

- **Setting the Constants**

The values can be set in the range of $-9.9999E+30$ to $9.9999E+30$.

10.4 Setting the Waveform Equation

Note

- If the result of the waveform computation is in error, the error data is plotted at the top edge of the screen. If this happens, the message "Math1 (Math2) Calc Error" is displayed on the screen. The computed results of data that is not in error is displayed as a waveform. If you save the waveform computation data to a file, the error data is recorded as ERROR. The computation results in error in the following cases.
 - If an operand of a voltage or current signal of an element that is not installed is used in the equation.*
 - If the torque or speed signal type is set to pulse.
 - If a negative value is substituted in the SQRT parameter.
 - If a negative value or zero is substituted in the LOG or LOG10 parameter.
 - If a division by zero occurs.
 - If any of the operands results in error.
 - * All of the data result in error, and the computed waveform is displayed as a line at the top edge of the screen.
 - An equation (Math1 or Math2) cannot be placed inside another equation (Math1 or Math2).
 - If the waveform is not displayed, the computed waveform may be turned OFF in the selection of the displayed waveform. For the procedure to turn the waveform ON, see section 6.2 in the *User's Manual IM760301-01E*.
-

10.5 Setting the Scale, Unit, and Label of the Computed Waveform

Procedure

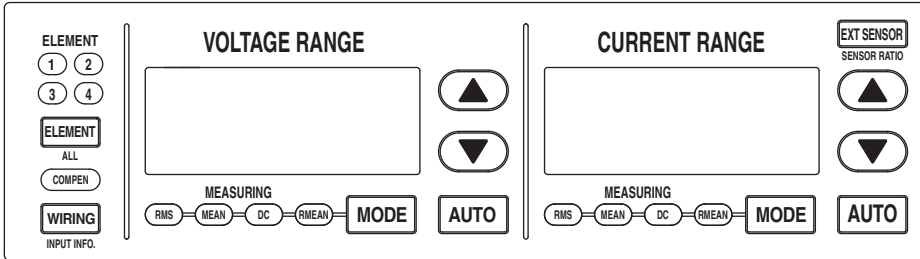

To exit the menu during operation, press **ESC** located above the soft keys.

In the procedural explanation below, the phrase “press the **cursor keys**” may be used. This phrase refers to the procedures for selecting items and entering values and character strings. For details on the procedures, see section 3.14 in the *User’s Manual IM760301-01E*.

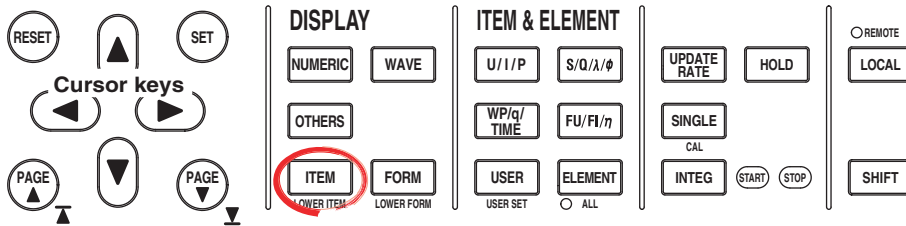

1. Press **ITEM** to display the Wave/Math Items menu.
If the waveform computation display is at the lower section of the screen on the split display, press **SHIFT+ITEM (LOWER ITEM)**.
2. Press the **Math Setup** soft key to display the Math Setup dialog box.

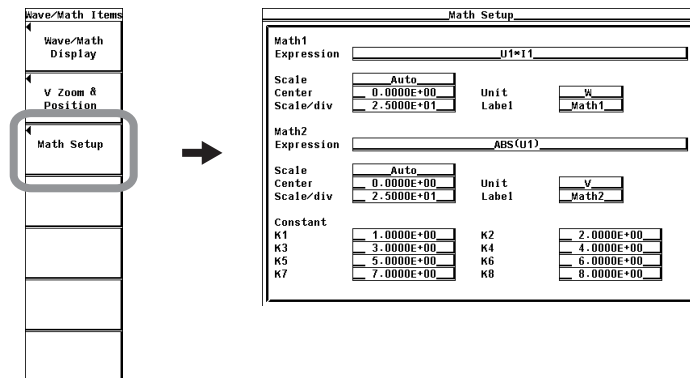

10.5 Setting the Sale, Unit, and Label of the Computed Waveform

- **Setting the Scaling of the Computed Waveform**
 - **Selecting Auto or Manual Scaling**
 3. Press the **cursor keys** to select Scale of Math1 or Math2.
 4. Press **SET** to display the scaling selection box.
 5. Press the **cursor keys** to select Auto or Manual.
 6. Press the **SET** key to confirm.

If you selected Auto, proceed to step 15 on the next page.
If you selected Manual, proceed to step 7.

Display example when Scale of Math1 is selected

Math Setup			
Math1	Expression <input type="text" value="U1*I1"/>		
Scale	<input type="button" value="Set"/>	Unit	<input type="text" value="W"/>
Center	<input type="button" value="Auto"/>	Label	<input type="text" value="Math1"/>
Scale/div	<input type="text" value="Manual"/>		
Math2	Expression <input type="text" value="ABS(U1)"/>		
Scale	<input type="text" value="Auto"/>	Unit	<input type="text" value="V"/>
Center	<input type="text" value="0.0000E+00"/>	Label	<input type="text" value="Math2"/>
Scale/div	<input type="text" value="2.5000E+01"/>		
Constant			
K1	<input type="text" value="1.0000E+00"/>	K2	<input type="text" value="2.0000E+00"/>
K3	<input type="text" value="3.0000E+00"/>	K4	<input type="text" value="4.0000E+00"/>
K5	<input type="text" value="5.0000E+00"/>	K6	<input type="text" value="6.0000E+00"/>
K7	<input type="text" value="7.0000E+00"/>	K8	<input type="text" value="8.0000E+00"/>

- **Setting the Center Value of Manual Scaling**
 7. Press the **cursor keys** to select Center of Math1 or Math2.
 8. Press **SET** to display the center value setup box.
 9. Press the **cursor keys** to set the center value.
 10. Press the **SET** key to confirm the center value.
- **Setting the Scale/Division Setting (Vertical Zoom Factor) of Manual Scaling**
 11. Press the **cursor keys** to select Scale/div of Math1 or Math2.
 12. Press **SET** to display the Scale/div setup box.
 13. Press the **cursor keys** to set the scale/division value.
 14. Press the **SET** to confirm the scale/division value.

Display example when Center of Math1 is selected

Math Setup			
Math1	Expression <input type="text" value="U1*I1"/>		
Scale	<input type="button" value="Set"/>	Unit	<input type="text" value="W"/>
Center	<input type="text" value="0.0000E+00"/>	Label	<input type="text" value="Math1"/>
Scale/div	<input type="text" value="2.5000E+01"/>		
Math2	Expression <input type="text" value="ABS(U1)"/>		
Scale	<input type="text" value="Auto"/>	Unit	<input type="text" value="V"/>
Center	<input type="text" value="0.0000E+00"/>	Label	<input type="text" value="Math2"/>
Scale/div	<input type="text" value="2.5000E+01"/>		
Constant			
K1	<input type="text" value="1.0000E+00"/>	K2	<input type="text" value="2.0000E+00"/>
K3	<input type="text" value="3.0000E+00"/>	K4	<input type="text" value="4.0000E+00"/>
K5	<input type="text" value="5.0000E+00"/>	K6	<input type="text" value="6.0000E+00"/>
K7	<input type="text" value="7.0000E+00"/>	K8	<input type="text" value="8.0000E+00"/>



Display example when Scale/div of Math1 is selected

Math Setup			
Math1	Expression <input type="text" value="U1*I1"/>		
Scale	<input type="text" value="Auto"/>	Unit	<input type="text" value="W"/>
Center	<input type="text" value="0.0000E+00"/>	Label	<input type="text" value="Math1"/>
Scale/div	<input type="text" value="2.5000E+01"/>		
Math2	Expression <input type="text" value="ABS(U1)"/>		
Scale	<input type="text" value="Auto"/>	Unit	<input type="text" value="V"/>
Center	<input type="text" value="0.0000E+00"/>	Label	<input type="text" value="Math2"/>
Scale/div	<input type="text" value="2.5000E+01"/>		
Constant			
K1	<input type="text" value="1.0000E+00"/>	K2	<input type="text" value="2.0000E+00"/>
K3	<input type="text" value="3.0000E+00"/>	K4	<input type="text" value="4.0000E+00"/>
K5	<input type="text" value="5.0000E+00"/>	K6	<input type="text" value="6.0000E+00"/>
K7	<input type="text" value="7.0000E+00"/>	K8	<input type="text" value="8.0000E+00"/>

- **Setting the Unit of the Computed Waveform**

15. Press the **cursor keys** to select Unit of Math1 or Math2.
16. Press **SET** to display the keyboard.
17. Use the **keyboard** to set the unit.

For keyboard operations, see section 3.14 in the *User's Manual IM760301-01E*.

Display example when Unit of Math1 is selected

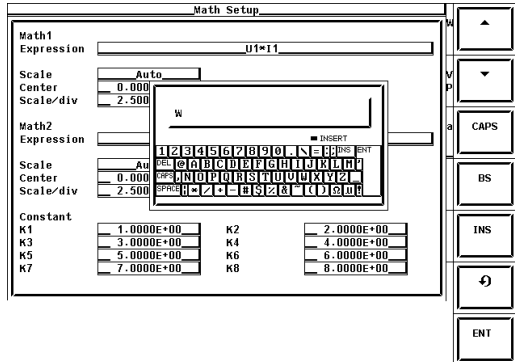

- **Setting the Label of the Computed Waveform**

18. Press the **cursor keys** to select Label of Math1 or Math2.
19. Press **SET** to display the keyboard.
20. Use the **keyboard** to set the label.

For keyboard operations, see section 3.14 in the *User's Manual IM760301-01E*.

Display example when Label of Math1 is selected

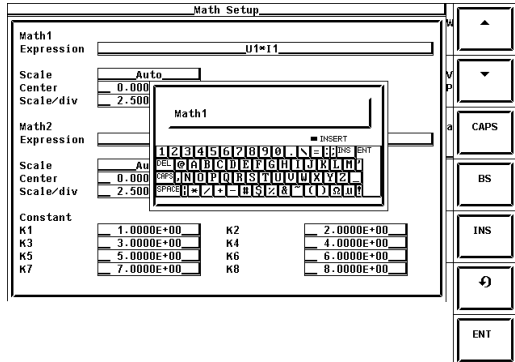

Explanation

- **Setting the Scale**

You can set the center value and the vertical zoom rate of the frame (scale/division) used to display the computed waveform. You can select the setup mode from below.

- Auto
Enables auto scaling. The upper and lower limits on the screen display are automatically determined from the maximum and minimum values of the computed result.
- Manual
Enables manual scaling. You can arbitrarily set the center value and the vertical zoom factor (scale/division).

Note

The display scale of the computed waveform may not be stable if you select auto scaling in the cases described below. In such case, use manual scaling.

- The amplitude of the input signal used in the waveform equation is not stable.
 - The amplitude of the computed waveform is near the threshold level used to switch the scaling setting.
-

- **Setting the Center Value and Vertical Zoom Factor (Scale/Division) for Manual Scaling**

The values can be set in the range of $-9.9999E+30$ to $9.9999E+30$.

- **Setting the Unit and Label**

- Number of Characters
8 characters or less
- Types of Characters
Characters that are displayed on the keyboard and spaces

10.6 Waveform Computation Function Specifications

Computation Function

Item	Specifications
Computed source	Voltage, current, and active power of each input element; torque (analog input) and speed (analog input) of motor input; and motor output
Equation	Two equations (MATH1 and MATH2)
Operator	+, -, *, /, ABS (absolute value), SQR (square), SQRT (square root), LOG (natural logarithm), LOG10 (common logarithm), EXP (exponent), NEG (negation), AVG2, AVG4, AVG8, AVG16, AVG32, AVG64 (exponential average).

Measurement Function

Item	Specifications
Sampling clock	Fixed to 200 kHz
Display update	Data update interval + computing time

Functional Limitations

Item	Specifications
Display	Trend display, bar graph display, vector display, and FFT display are not allowed.
Harmonic measurement	Not allowed
Equation for apparent power and reactive power	Type3 not selectable. If waveform computation mode is enabled while Type3 is set, Type1 is automatically selected.
Integration	Not allowed
Store	Not allowed
Synchronized measurement	Not allowed
Auto print	Integration synchronization is not allowed.

Measurement Functions

Measurement is not allowed for measurement functions related to the functions above that have limitations. For a list of measurement functions that cannot be measured, see appendices 10 and 11 in the *User's Manual IM760301-01E*.

11.1 FFT Function

This function allows the power spectrum of the input signal to be displayed through FFT (fast Fourier transform). This is useful when you wish to check the frequency distribution of the input signal.

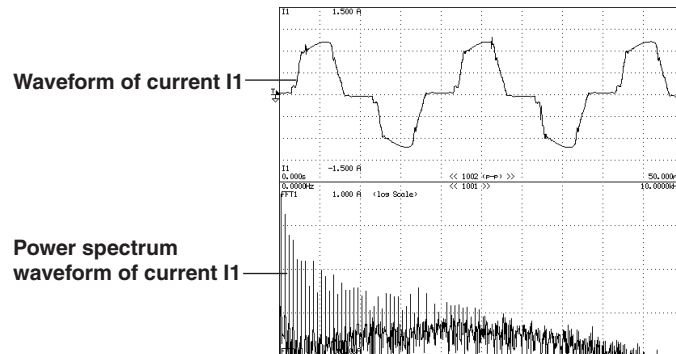

- **FFT Source**

You can select the source for taking the FFT from the following:

- Voltage, current, active power, and reactive power of each input element.
- Active power and reactive power of an Σ wiring unit.
- Torque and speed signals of motor input (motor version).

FFT can be performed simultaneously on two sources.

- **FFT Window**

You can select the FFT window from the following three types.

- **Rectangular (Rect)**

This window is effective on repetitive waveform of AC signals whose period is equal to an integer multiple of the FFT measurement period. The FFT measurement period is set to 1 s or 100 ms by setting the number of FFT points (200 k or 20 k).

For example, the rectangular window is effective on 50-Hz or 60-Hz signal with repetitive waveform, because the above conditions are met.

- **Hanning and FlatTop**

These windows are effective on waveforms that do not meet the conditions for the rectangular window. The Hanning and flattop windows allow continuity of the signal by gradually attenuating the parts of the signal located near the ends of the time window down to the 0 level.

For example, if the input frequency is 52.2 Hz, the integer multiple of the period is not equal to the FFT measurement period. If the rectangular window is used in this case, frequency components that do not actually exist are detected and appear as side lobes.

Frequency components that do not actually exist are also detected using the Hanning or flattop window, but the level of the non-existing frequency components can be kept small as compared with the rectangular window. The figures on the next page show a conceptual diagram of the result obtained by taking the FFT on a 52.2-Hz sine wave using each window.

With the Hanning window, the frequency resolution is high compared to the flattop window. However, the flattop window has a higher level of accuracy.

When the FFT source is a continuous signal, select the proper window for the application.

FFT Measurement Examples (Conceptual Diagrams)

- Input signal: 52.2-Hz sine wave
- Number of FFT points: 200 k (FFT measurement time: 1 s)
- Left end of the graph: dc, right end: 100 Hz

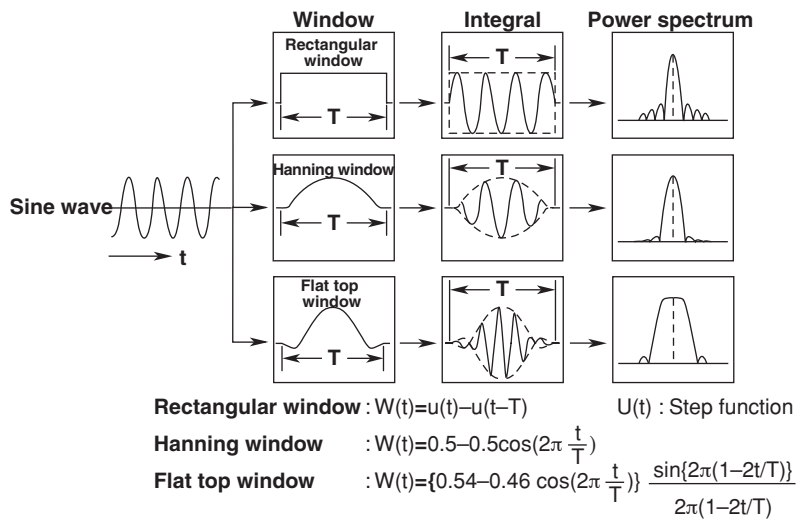

• **Number of FFT Points and Frequency Resolution**

The frequency range of the FFT is DC to 100 kHz. FFT is performed on 20000 points or 200000 points of measured data, and the result is displayed using 10001 data points or 100001 data points, respectively.

- **FFT Function**

The power spectrum can be derived from the equations below.

- **Voltage, Current, and Power**

The complex function of the voltage after taking the FFT is assumed to be $U = U_r + jU_j$, and that of the current is assumed to be $I = I_r + jI_j$.

$$\text{Power spectrum of voltage} = \sqrt{\frac{U_r^2 + U_j^2}{2}}$$

$$\text{Power spectrum of current} = \sqrt{\frac{I_r^2 + I_j^2}{2}}$$

$$\text{Power spectrum of active power} = U_r I_r + U_j I_j$$

$$\text{Power spectrum of reactive power} = U_r I_j - U_j I_r$$

U_r, I_r : Real Part U_j, I_j : Imaginary Part

- **Torque and Speed**

The complex function of the torque signal after taking the FFT is assumed to be $T = T_r + jT_j$, and that of the speed signal is assumed to be $S = S_r + jS_j$.

$$\text{Power spectrum of torque} = \sqrt{\frac{T_r^2 + T_j^2}{2}}$$

$$\text{Power spectrum of speed} = \sqrt{\frac{S_r^2 + S_j^2}{2}}$$

T_r, S_r : Real Part T_j, S_j : Imaginary Part

- **Differences between the Harmonic Measurement and FFT on the WT3000**

In harmonic measurement, the source signal is sampled at a sample rate that is in sync with the PLL source, and component signals that are integer multiples of the fundamental wave are measured. Therefore, harmonic measurement is suited to measuring signals that include only the harmonics that are integer multiples of the fundamental wave and can be used to determine the impedance of each harmonic order or the total of all harmonics.

In FFT, the source signal is sampled at a fixed sample rate, and Fast Fourier transform is taken on the bandwidth up to a half of the sampling rate. Therefore, it is suited to analyzing signals that include components (distorted waveform and noise) that are not integer multiples of the fundamental wave.

- **Limitations on the Function and Measurement Function**

FFT mode performs internal computation differently from other measurement modes. Therefore, some functions such as trend and bar graph displays on the screen, integration, and storage function cannot be used in this measurement mode. In addition, some measurement functions such as harmonic measurement and impedance cannot be carried out. For a list of functions with limitations and measurement functions that cannot be measured, see appendix 10 and 11 in the *User's Manual IM760301-01E*.

Note

In FFT mode, TYPE 3 cannot be selected for the equation of the apparent or reactive power. If TYPE3 is selected and you select FFT mode, the equation switches to TYPE1. For details on the type of equations, see section 2.5 and 5.9 in the *User's Manual IM760301-01E*.

- **Rms Values of Voltage U and Current I**

The rms values of the voltage U and current I that are measured in the FFT mode are normal measured values. For details on the normal measured value, see "Relationship between the Rms Values of Voltage U/Current I and Measurement Modes" in section 7.1.

11.2 Various Settings Related to FFT

A portion of the settings related to FFT is common with the “waveform display in normal measurement mode” and “FFT mode.” The settings described in sections 11.3 to 11.9 are those specific to the FFT. Set these items first.

- **Setting the FFT mode** **Section 11.3**
- **Selecting the power spectrum to be displayed, selecting the FFT source, and setting the label** **Section 11.4**
- **Setting the number of computed points and time window** **Section 11.5**
- **Setting the display range of the X-axis (frequency) and the scale type of the Y-axis (signal amplitude)** **Section 11.6**
- **Setting the display type of the power spectrum** **Section 11.7**
- **Displaying the power spectrum on the split screen.** **Section 11.8**
- **Cursor measurement** **Section 11.9**

The settings below are common with the waveform display of normal measurement mode. See the respective sections below in the *User's Manual IM760301-01E*.

- **Setting the trigger** **Section 6.4**
- **Selecting the display interpolation and graticule** **Section 6.7**
- **Turning ON/OFF the Scale Value Display** **Section 6.8**

If you change settings that are common with the “waveform display in normal measurement mode” and “waveform computation mode” in FFT mode, the waveform display settings in normal measurement mode and waveform computation mode are also changed. For example, if the scale value display is turned OFF in FFT mode, the scale value display in “waveform display in normal measurement mode” and “waveform computation mode” are also turned OFF.

The anti-aliasing filter setting is the same as with the harmonic measurement in normal measurement mode. See the following section.

- **Setting the anti-aliasing filter** **Section 7.8**

11.3 Setting the FFT Mode

Procedure

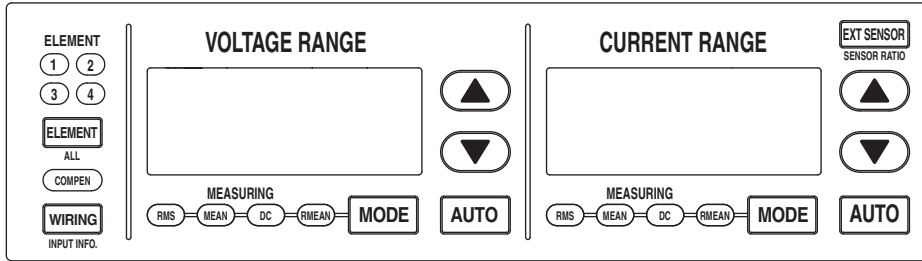

To exit the menu during operation, press **ESC** located above the soft keys.

In the procedural explanation below, the phrase “press the **cursor keys**” may be used. This phrase refers to the procedures for selecting items and entering values and character strings. For details on the procedures, see section 3.14 in the *User's Manual IM760301-01E*.

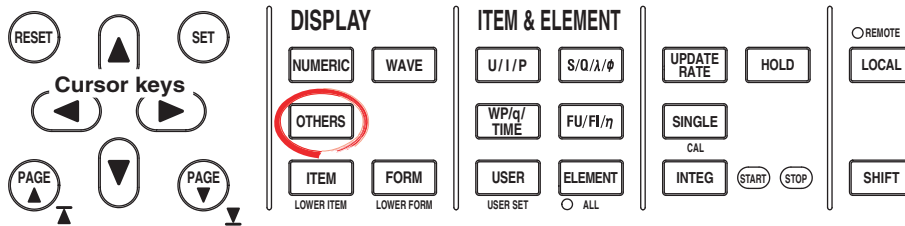

• Enabling FFT Mode

1. Press **OTHERS** to display the Others menu.
2. Press the **FFT**, **Numeric+FFT**, or **Wave+FFT** soft key.

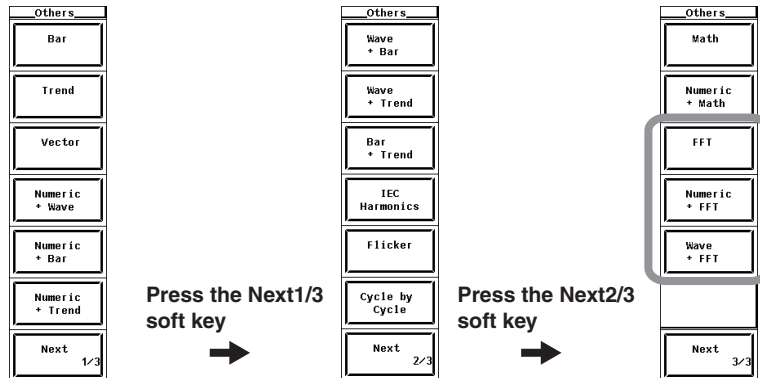

11.3 Setting the FT Mode

Explanation

A display example is shown below. The vertical axis is in logarithmic scale. The words <log Scale> is displayed to the right of the upper limit of the power spectrum.

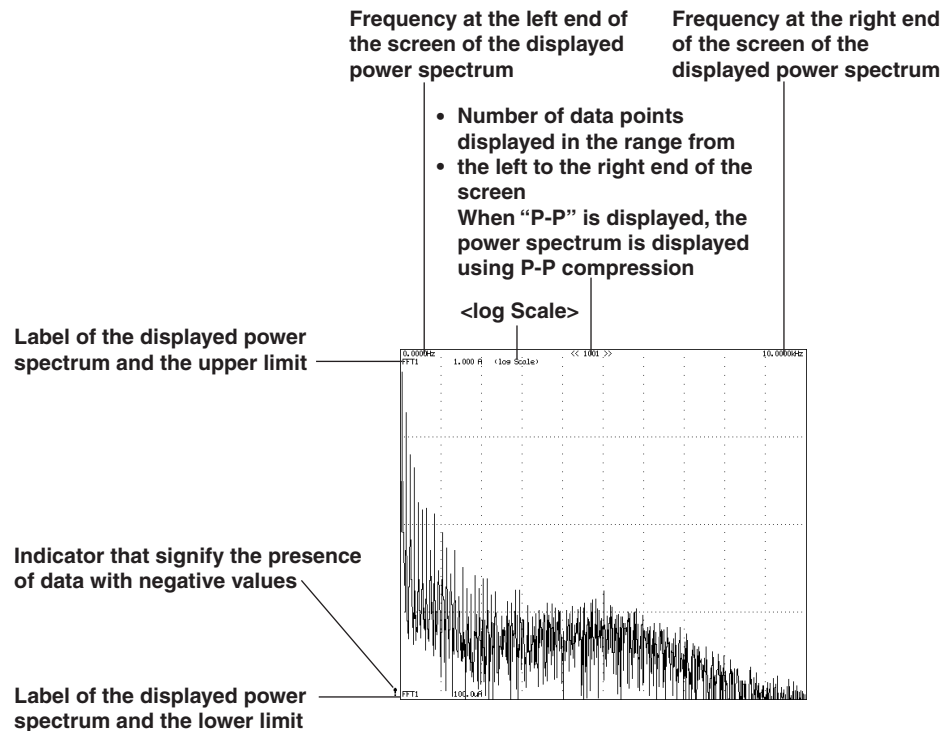

You can select the display format of the FFT data (power spectrum waveform) from the list below.

- **Displaying the Power Spectrum Waveform on the Entire Screen.**
If you select FFT, the power spectrum waveform is displayed on the entire screen.
 - **Displaying the Power Spectrum Waveform by Dividing the Screen into Halves (Split Screen)**
 - **Numeric+FFT**
The numeric data and power spectrum waveform are displayed separately in the top and bottom windows.
 - **Wave+FFT**
The waveform and power spectrum waveform are displayed separately in the top and bottom windows.
- For waveform display settings, see the *User's Manual IM760301-01E*.

The measurement period of the waveform data and that of the FFT may not be synchronized.

Note

The display update interval in FFT mode is the data update rate + computing time. The computing time is approximately 10 s when the number of computed points (see section 11.4) is 200 k. Therefore, it may take more than 10 s for the power spectrum to be displayed when the FFT mode is enabled.

11.4 Selecting the Power Spectrum to Be Displayed, Selecting the FFT Source, and Setting the Label

Procedure

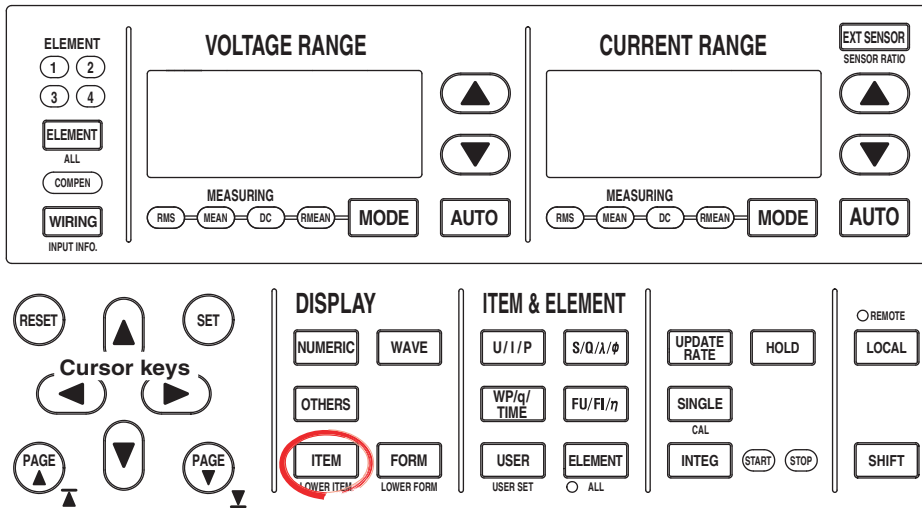

To exit the menu during operation, press **ESC** located above the soft keys.

In the procedural explanation below, the phrase “press the **cursor keys**” may be used. This phrase refers to the procedures for selecting items and entering values and character strings. For details on the procedures, see section 3.14 in the *User’s Manual IM760301-01E*.

1. Press **ITEM** to display the FFT Items menu.
If the FFT display is at the lower section of the screen on the split display, press **SHIFT+ITEM (LOWER ITEM)**.
- **Selecting the Power Spectrum to Be Displayed**
2. Press the **FFT1 Display** or **FFT2 Display** soft key to select ON or OFF.

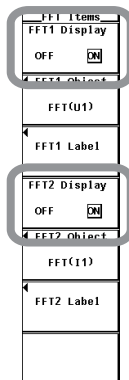

11.4 Selecting the Power Spectrum to Be Displayed, Selecting the FFT Source, and Setting the Label

- **Selecting the FFT Source**

3. Press the **FFT1 Object** or **FFT2 Object** soft key to display the FFT source selection box.
4. Press the **cursor keys** to select the FFT source.
5. Press the **SET** key to confirm.

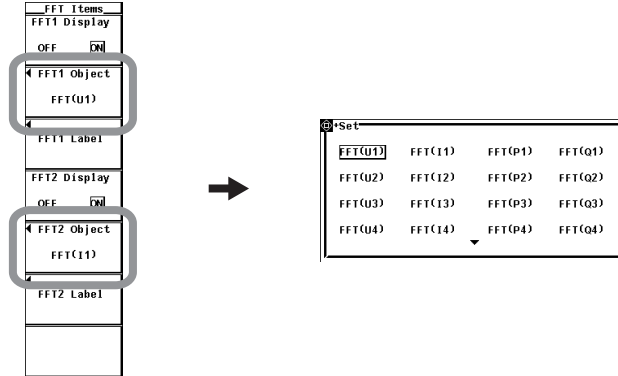

- **Setting the Label**

6. Press the **FFT1 Label** or **FFT2 Label** soft key to display the keyboard.
7. Use the **keyboard** to set the label.

For keyboard operations, see section 3.14 in the *User's Manual IM760301-01E*.

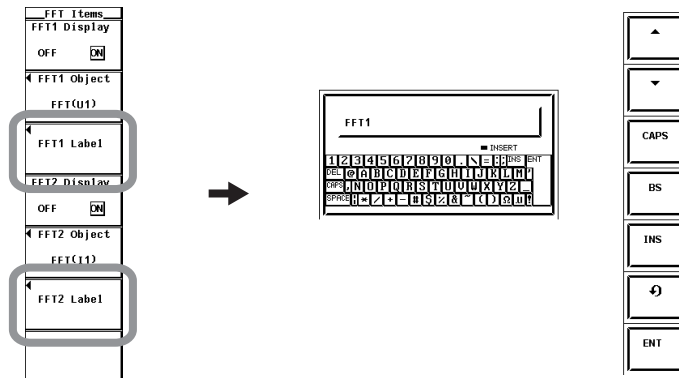

Explanation

- **Selecting the Power Spectrum to Be Displayed**

You can turn ON/OFF power spectrum 1 (FFT1) and power spectrum 2 (FFT2).

- **Selecting the FFT Source**

Select the source on which to take the FFT from below. Two FFTs (FFT1 and FFT2) can be set.

- Voltage, current, active power, and reactive power of each input element.
- Active power and reactive power of an Σ wiring unit.
- Torque and speed signals (analog input) of motor input (motor version).

Note

FFT cannot be performed if the type of torque signal or speed signal of the motor input is pulse. The screen displays "Calc Error."

- **Setting the Label**

- Number of Characters
8 characters or less
- Types of Characters
Characters that are displayed on the keyboard and spaces

11.5 Setting the Number of Computed Points and Time Window

Procedure

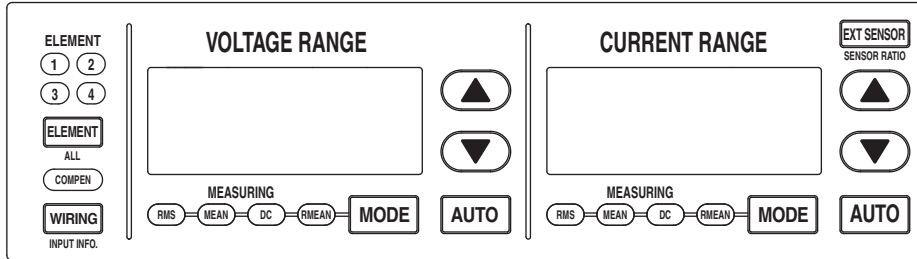

To exit the menu during operation, press **ESC** located above the soft keys.

In the procedural explanation below, the phrase “press the **cursor keys**” may be used. This phrase refers to the procedures for selecting items and entering values and character strings. For details on the procedures, see section 3.14 in the *User's Manual IM760301-01E*.

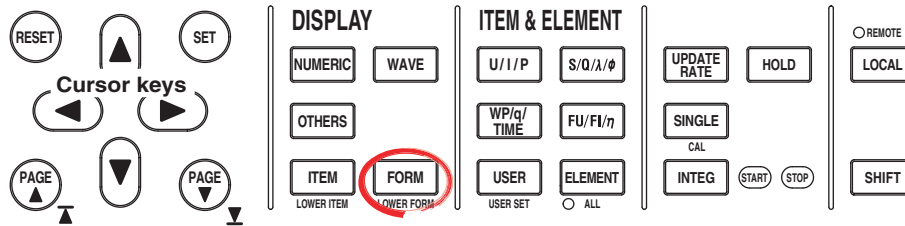

1. Press **FORM** to display the FFT Form menu.
If the FFT display is at the lower section of the screen on the split display, press **SHIFT+FORM (LOWER FORM)**.
- **Selecting the Number of Computed Points**
 2. Press the **FFT Points** soft key to display the FFT Points menu.
 3. Press the **200k** or **20k** soft key to select the number of computed points.

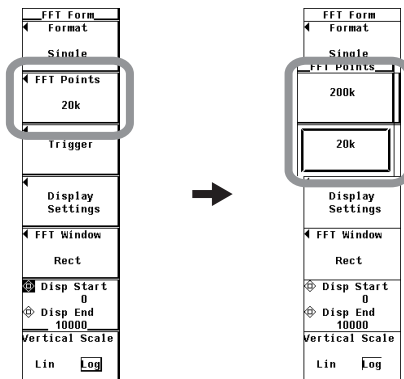

- **Selecting the Time Window**
 3. Press the **FFT Window** soft key to display the FFT Window menu.
 4. Press the **Rect**, **Hanning**, or **FlatTop** soft key to select the time window.

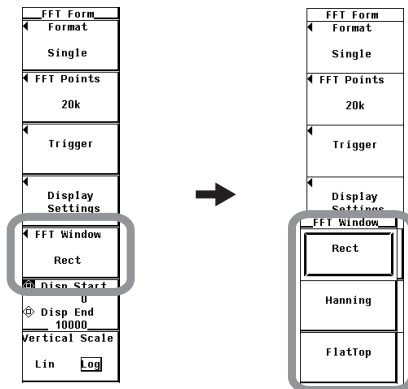

Explanation

- **Setting the Number of Computed Points**
 You can select 200 k (200000 points) or 20 k (20000 points). The frequency resolution varies depending on the number of computed points as follows:

Number of Computed Points	Frequency Resolution	Measurement Period for the FFT
200 k	1 Hz	1 s
20 k	10 Hz	100 ms

Note

If the number of computed points is set to 200 k, FFT takes approximately 10 s. The display update interval is determined by the longer of the two values, the data update rate and (the measurement period of the FFT + FFT computing time). Thus, it may take more than 10 s for the display to be updated.

- **Selecting the Time Window**
 Select from the three types listed below. For details on the time window, see section 11.1.
 - **Rect (Rectangular)**
 This window is effective on repetitive waveform of AC signals whose period is equal to an integer multiple of the FFT measurement period. For example, the rectangular window is effective on 50-Hz or 60-Hz signal with repetitive waveform.
 - **Hanning**
 This window is effective on waveforms that do not meet the conditions for the rectangular window. The frequency resolution of the Hanning window is high compared to the flattop window.
 - **FlatTop**
 This window is effective on waveforms that do not meet the conditions for the rectangular window. The flattop window has a higher level of accuracy than the Hanning window.

11.6 Setting the Display Range of the X-Axis (Frequency) and the Scale Type of the Y-Axis (Signal Amplitude)

Procedure

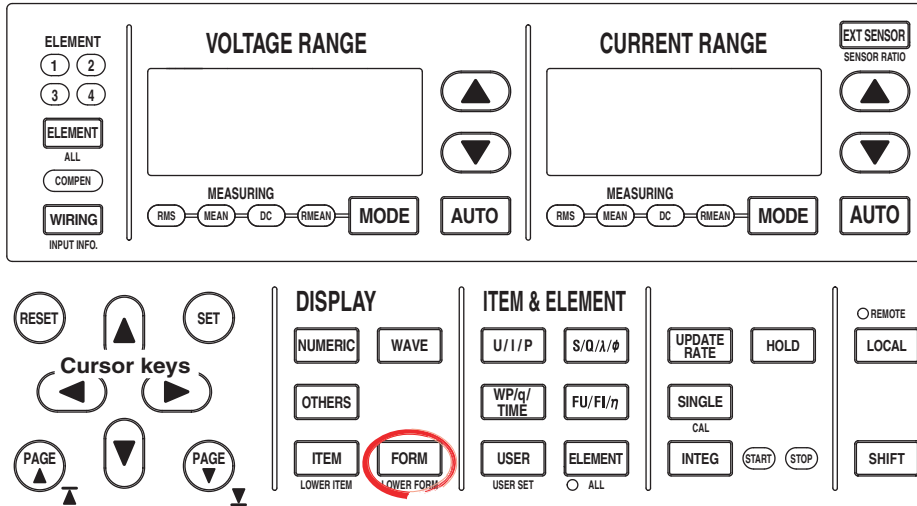

To exit the menu during operation, press **ESC** located above the soft keys.

In the procedural explanation below, the phrase “press the **cursor keys**” may be used. This phrase refers to the procedures for selecting items and entering values and character strings. For details on the procedures, see section 3.14 in the *User's Manual IM760301-01E*.

1. Press **FORM** to display the FFT Form menu.
 - If the FFT display is at the lower section of the screen on the split display, press **SHIFT+FORM (LOWER FORM)**.
- **Setting the Display Range of the X-Axis (Frequency)**
 2. Press the **Disp Start/Disp End** soft key to select Disp Start, Disp end, or both Disp Start and Disp End.
 - If you select Disp Start, you can set the left end of the power spectrum display (minimum value of the computed points).
 - If you select Disp End, you can set the right end of the power spectrum display (maximum value of the computed points).
 - If you select both Disp Start and Disp End, you can set the computed points of the power spectrum display without changing the offset between the computed points of Disp Start and Disp End. The cursor is displayed at Disp Start.
 3. Press the **cursor keys** to set the computed point.

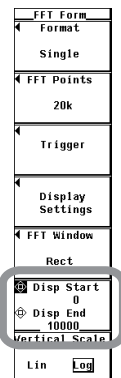

11.6 Setting the Display Range of the X-Axis (Frequency) and the Scale Type of the Y-Axis (Signal Amplitude)

- **Selecting the Scale Type of the Y-Axis (Signal Amplitude)**
 4. Press the **Vertical Scale** soft key to select Lin or Log.

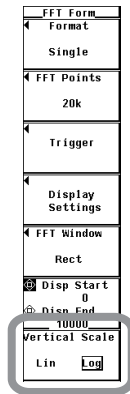

Explanation

- **Selecting the Display Range of the X-Axis (Frequency)**

You can set the left and right ends of the power spectrum display.

 - Disp Start (left end of the display)
Set the value in the range of 0 to 99990.
 - Disp End (right end of the display)
Set the value in the range of 10 to 100000.
 - The difference between Disp Start and Disp End must be greater than or equal to 10.
 - The relationship between the Disp Start and Disp End settings and the frequencies at the left and right ends of the power spectrum display varies depending on the number of computed points (section 11.5). For example, if the number of computed points is set to 20 k and Disp Start is set to 5, the frequency at the left end of the display is 50 Hz. If the number of computed points is set to 200 k and Disp Start is set to 5, the frequency at the left end of the display is 5 Hz.
- **Selecting the Scale Type of the Y-Axis (Signal Amplitude)**

You can select LIN (linear) or LOG (logarithmic).

 - If you select LIN, the maximum value of the Y-axis is determined automatically from the measurement range. The minimum value is zero.
 - If you select LOG, the maximum value of the Y-axis is one digit above the measurement range, and is a value that is an integer power of 10. The minimum value is equal to 1/10000 of the maximum value.

Note

- If the number of computed points (section 11.5) is 20 k (20000 points), the power spectrum data is 0 to 10000. In this case, if you set a value greater than 10000 as the display range of the X-axis (frequency), the power spectrum is not displayed above 10000.
- If the scale type of the Y-axis (signal amplitude) is set to LOG, the data smaller than the minimum value of the Y-axis is not displayed.
- If FFT is taken on an input signal that is close to a sine wave with little distortion, the power spectrum may appear as though it is not displayed. This is because the signal contains little harmonic components. In this case, the power spectrum is displayed only on the Y-axis at the left end of the display. If this happens, change the settings as follows.
 - Set the Disp End (right end of the screen) to a small value.
 - Set the scale type of the Y-axis (signal amplitude) to LOG (logarithmic).

11.7 Selecting the Display Type of the Power Spectrum

Procedure

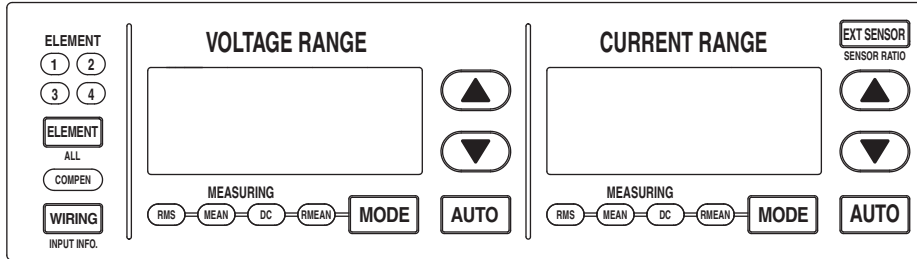

To exit the menu during operation, press **ESC** located above the soft keys.

In the procedural explanation below, the phrase “press the **cursor keys**” may be used. This phrase refers to the procedures for selecting items and entering values and character strings. For details on the procedures, see section 3.14 in the *User's Manual IM760301-01E*.

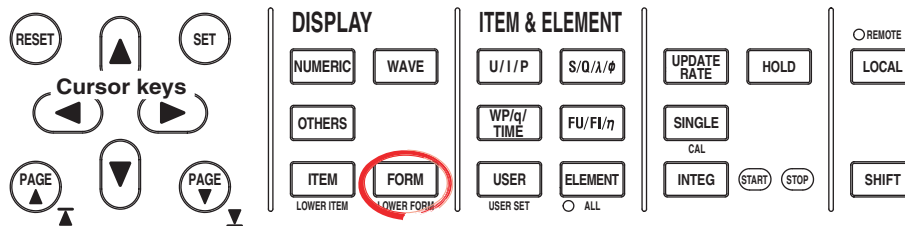

1. Press **FORM** to display the FFT Form menu.
If the FFT display is at the lower section of the screen on the split display, press **SHIFT+FORM (LOWER FORM)**.
2. Press the **Display Settings** soft key to display the Disp Settings menu.
3. Press the **Spectrum Type** soft key to select Line or Bar.

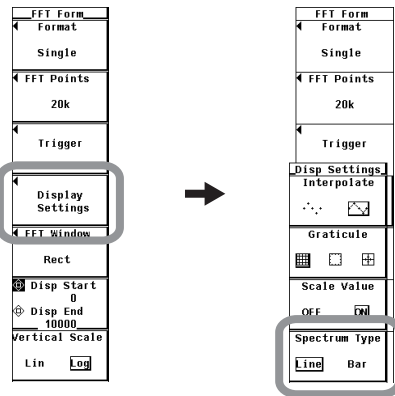

Explanation

- **Display Type of the Power Spectrum**

Select either of the two types below.

- Line: The FFT data is connected with lines. The display is a line graph.
- Bar: The FFT data is displayed on a bar graph.

- **Display of Data with Negative Values**

Data whose value is negative is displayed as follows:

- Line

The data is not displayed. If there is data with negative values, an exclamation point is displayed at the left of the screen. To display the negative data, change the display type of the power spectrum to Bar.

- Bar

The absolute value of the negative data is displayed with a red bar graph. For example, if the 0-Hz (DC) component is negative, it is displayed as shown below. However, if the absolute value of the data is small with respect to the Y-axis scale, it may not appear on the screen.

When the power spectrum display type is set to Line

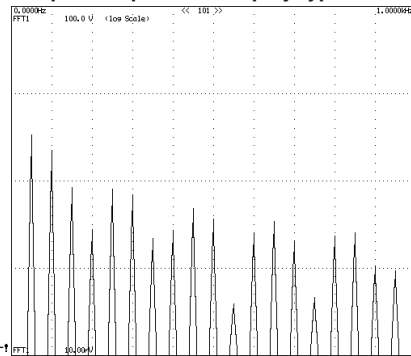

Indicator that signify the presence of data with negative values

When the power spectrum display type is set to Bar

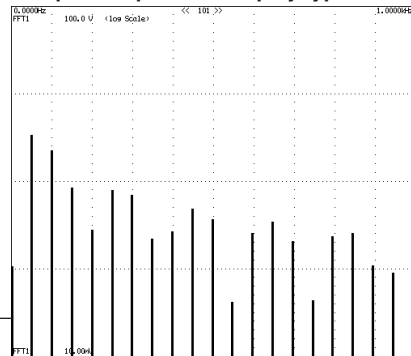

Displays data with negative values with a red bar graph

11.8 Displaying the Power Spectrum on the Split Screen

Procedure

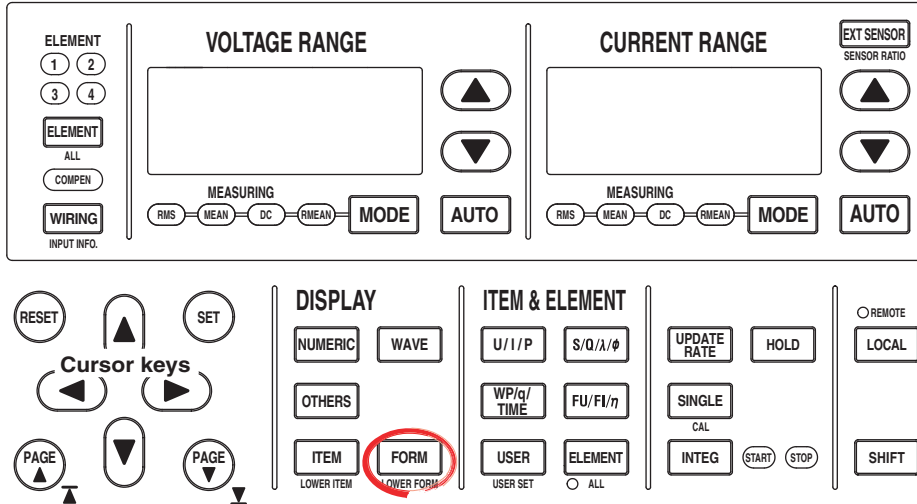

To exit the menu during operation, press **ESC** located above the soft keys.

In the procedural explanation below, the phrase “press the **cursor keys**” may be used. This phrase refers to the procedures for selecting items and entering values and character strings. For details on the procedures, see section 3.14 in the *User's Manual IM760301-01E*.

1. Press **FORM** to display the FFT Form menu.
If the FFT display is at the lower section of the screen on the split display, press **SHIFT+FORM (LOWER FORM)**.
2. Press the **Format** soft key to display the FFT Format menu.
3. Press one of the keys from **Single** or **Dual** to select the number of windows.

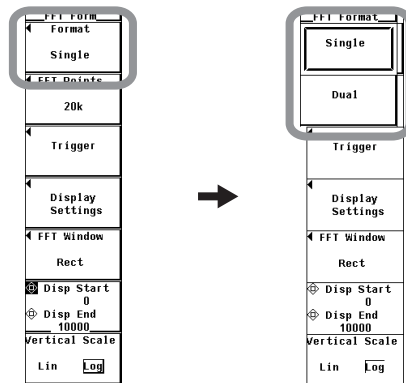

Explanation

The screen can be evenly divided and the waveforms can be assigned to the divided windows. Select the number of divisions of the screen from the choices below.

- Single: 1 window
- Dual: 2 equally divided windows

The number of displayed points in the vertical direction of one divided window varies depending on the number of divisions as follows:

- Single: 432 points
- Dual: 216 points

11.9 Cursor Measurement

Procedure

DISPLAY

NUMERIC WAVE OTHERS ITEM FORM

ITEM & ELEMENT

U/I/P S/Q/A/P WP/q/TIME FU/Fl/η USER ELEMENT

UPDATE RATE HOLD SINGLE CAL INTEG START STOP

REMOTE LOCAL SHIFT

To exit the menu during operation, press **ESC** located above the soft keys.

In the procedural explanation below, the phrase “press the **cursor keys**” may be used. This phrase refers to the procedures for selecting items and entering values and character strings. For details on the procedures, see section 3.14 in the *User’s Manual IM760301-01E*.

1. Press **SHIFT+MEASURE(CURSOR)** to display the Cursor menu.
For split screen of Wave+FFT, proceed to step 2. For all other displays, proceed to step 3.
2. Press the **FFT Cursor Setting** soft key to display the Cursor menu for the FFT display.

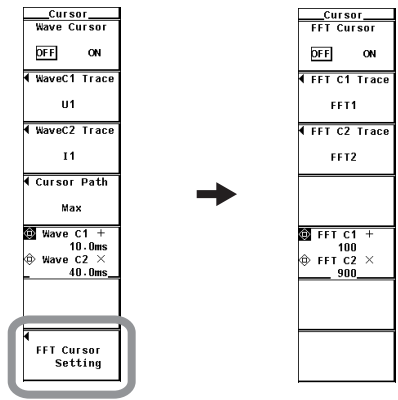

11.9 Cursor Measurement

- **Turning ON/OFF Cursor Measurement**

3. Press the **FFT Cursor** soft key to select ON or OFF.

If ON is selected, the result of the cursor measurement is displayed.

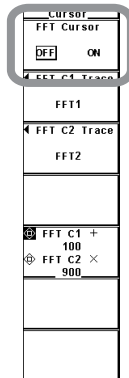

- **Selecting the Source FFT for Cursor Measurement**

- **Selecting the Source FFT for Cursor +**

4. Press the **FFT C1 Trace** soft key to display the source FFT selection box.

5. Press the **cursor keys** to select FFT1 or FFT2.

6. Press the **SET** key to confirm the source FFT.

- **Selecting the Source FFT for Cursor x**

4. Press the **FFT C2 Trace** soft key to display the source FFT selection box.

5. Press the **cursor keys** to select FFT1 or FFT2.

6. Press the **SET** key to confirm the source FFT.

- **Moving the Cursors**

7. Press the **FFT C1 +/FFT C2 x** soft key to set the jog shuttle target to FFT C1 +, FFT C2 x, or both FFT C1 + and FFT C2 x.

- If you select FFT C1 +, the position of cursor + can be moved.

- If you select FFT C2 x, the position of cursor x can be moved.

- If you select both FFT C1 + and FFT C2 x, the two cursors can be moved without changing the spacing between the two. The value of the digit being specified by FFT C1 + changes.

8. Press the **cursor keys** to set the move the cursors.

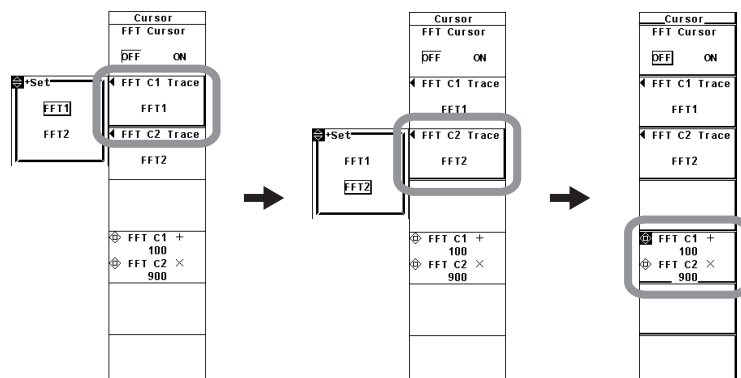

Explanation

- **ON/OFF**

Cursors can be placed on the displayed power spectrum waveform to measure and display the value at any point. It can be used to measure the data on the vertical axis (Y-axis) and horizontal axis (X-axis) of various sections of the power spectrum waveform.

- ON: Performs cursor measurement.
- OFF: Does not perform cursor measurement.

- **Measured Source**

The source FFT of the cursor measurement can be set to FFT1 or FFT2.

- **Moving the Cursors**

- Cursors move on the selected power spectrum waveform.
- The cursors moves along the data points displayed on the screen one point at a time.
- The cursor movement varies depending on the display range (section 11.6) of the X-axis (frequency) as follows:
 - Less than or equal to 1002 points
Specify the number of points from the left end of the screen to move the cursor with the left and right ends of the screen assumed to be point 0 and the point corresponding to the number of points of the display range, respectively.
 - Greater than 1002 points ("1002(P-P)" is displayed at the center of the top section of the screen)
Specify the number of points from the left end of the screen to move the cursor with the left and right ends of the screen assumed to be point 0 and 1001, respectively.

- **Measurement Item**

- Y+: Vertical value of cursor + (Y-axis value)
- Yx: Vertical value of cursor x (Y-axis value)
- ΔY : The difference between the Y-axis values of cursor + and cursor x
- X+: Horizontal value of cursor + (X-axis value, frequency)
- Xx: Horizontal value of cursor x (X-axis value, frequency)
- ΔX : The difference between the X-axis values of cursor + and cursor x

Note

- If immeasurable data exists, *** is displayed in the measured value display area.
- ΔY is measured even if the unit is different. The result has no unit in this case.

11.10 FFT Function Specifications

Computation Function

Item	Specifications
Computed source	Voltage, current, active power, and reactive power of each input element. Active power and reactive power of an Σ wiring unit. Torque and speed signals (analog input) of motor input (option).
Type	PS (power spectrum)
Number of computations	Two computations (FFT1 and FFT2)
Maximum frequency of analysis	100 kHz
Number of points	20,000 points or 200,000 points
Measurement period for the computation	100 ms or 1 s
Frequency resolution	10 Hz or 1 Hz
Window function	Rectangular, Hanning, or Flattop
Anti-aliasing filter	Set using a line filter (OFF, 500 Hz, 5.5 kHz, or 50 kHz).

Measurement Function

Item	Specifications
Sampling clock	Fixed to 200 kHz
Display update	Data update rate or (measurement period of the FFT + FFT computing time), whichever is longer

* The measurement period is 1 s when the number of FFT points is 200 k (when the frequency resolution is 1 Hz).
The measurement period is 100 ms when the number of FFT points is 20 k (when the frequency resolution is 10 Hz).

Functional Limitations

Item	Specifications
Display	Trend display, bar graph display, vector display, and waveform computation display are not allowed.
Harmonic measurement	Not allowed
Equation for apparent power and reactive power	Type3 not selectable. If FFT mode is enabled while Type3 is set, Type1 is automatically selected.
Integration	Not allowed
Store	Not allowed
Synchronized measurement	Not allowed
Auto print	Integration synchronization is not allowed.

Measurement Functions

Measurement is not allowed for measurement functions related to the functions above that have limitations. For a list of measurement functions that cannot be measured, see appendices 10 and 11 in the *User's Manual IM760301-01E*.

12.1 Voltage Fluctuation and Flicker Measurement Function

This function allows you to perform voltage fluctuation and flicker measurements conforming to IEC61000-3-3. If you use the Harmonic/Flicker Measurement Software sold separately, you can print a report of the measurement judgement results.

- **Connecting to the Harmonic/Flicker Measurement Software**

For details on connecting the WT3000 to the Harmonic/Flicker Measurement Software, see the user's manual of the Harmonic/Flicker Measurement Software.

When you use the Harmonic/Flicker Measurement Software, the WT3000 enters remote mode in which key operations on the WT3000 are disabled. The settings described in the subsequent sections are set automatically or set from the setup screen of the software.

Note

Do not release the remote mode of the WT3000 and change the settings while operating the WT3000 with the Harmonic/Flicker Measurement Software. Doing so may impede voltage fluctuation and flicker measurements conforming to the IEC standard. If you release the remote mode of the WT3000, close the Harmonic/Flicker Measurement Software.

- **Measurement Items (Measurement Functions)**

- Rated voltage U_n
- Voltage frequency Freq
- Relative steady-state voltage change d_c
- Maximum relative voltage change d_{max}
- Period during which relative voltage change exceeds the threshold level $d(t)$
- Short-term flicker value P_{st}
- Long-term flicker value Plt
- Instantaneous flicker sensation (IFS)^{*1}
- Cumulative probability function (CPF)^{*1}

*1 Cannot be displayed on the WT3000 screen. The value can be displayed on the screen of the Harmonic/Flicker Measurement Software.

- **Measurement Method**

The following two voltage fluctuation and flicker measurement methods are available.

- **Normal flicker measurement**

Calculates all the values of d_c , d_{max} , $d(t)$, P_{st} , and Plt , compares them to the preset limits, and indicates the total judgement.

- **Measurement of d_{max} caused by manual switching**

Measures the maximum relative voltage change, d_{max} , when the EUT switch is manually turned ON and OFF, determines the average over 24 measurements, and compares and judges against the limit.

- **Data Update Interval**

The display update interval in voltage fluctuation and flicker measurement mode is 2 s.

12.1 Voltage Fluctuation and Flicker Measurement Function

- **Limitations on the Function and Measurement Function**

In voltage fluctuation and flicker measurement mode, the internal computation is different from other measurement modes in order to achieve measurements conforming to the IEC standard. Therefore, some functions such as waveform or bar graph display on the screen, store function, motor evaluation function (motor version) cannot be used in this measurement mode. In addition, some measurement functions such as integration and efficiency computation cannot be carried out. For a list of functions with limitations and measurement functions that cannot be measured, see appendices 10 and 11 in the *User's Manual IM760301-01E*.

- **Saving the Voltage Fluctuation and Flicker Measurement Data**

The voltage fluctuation and flicker measurement data cannot be saved on the WT3000. Use the Harmonic/Flicker Measurement Software and save the data on the PC.

- **For details on the power supply for testing, test conditions, and terminology, see IEC61000-3-3.**

- **Terminology**

Flicker

Flicker refers to the unstable impression perceived by the human eye that is induced by the fluctuating intensity or spectral distribution of light. It expresses the irritation that the people receive due to the fluctuation of brightness.

Steady-state condition

A condition in which the rms voltage for each half period is stable for 1 s or more.

Relative steady-state voltage change dc

A value obtained by dividing the difference between two steady-state voltages before and after a single voltage fluctuation by the rated voltage expressed as a percentage. For example, for a power supply with a rated voltage of 230 V, the relative steady-state voltage change is as shown below if the steady-state voltage before the fluctuation is 231 V and that after the fluctuation is 232 V.

$$\left| \frac{232 - 231}{230} \right| \times 100 (\%) = 0.43\%$$

Note

- If no voltage fluctuation occurs in the measurement period, dc is zero.
 - If a steady-state condition does not occur during the measurement period, it is considered to be a fluctuating condition. The measured value of dc is displayed as Undef (undefined), and the judgement is displayed as Error.
-

Maximum relative voltage change dmax

A value obtained by dividing the difference between the maximum and minimum values in a single voltage fluctuation^{*1} by the rated voltage expressed as a percentage.

*1 Condition between two steady-state conditions.

Period during which relative voltage change exceeds the threshold level d(t)

The time during which the relative voltage change during a voltage fluctuation period exceeds the threshold level.

Relationship between dc, dmax, and d(t)

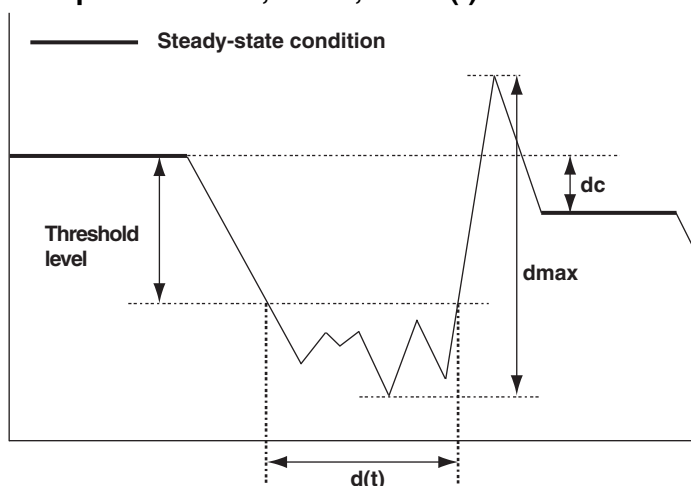

Display Example of dc

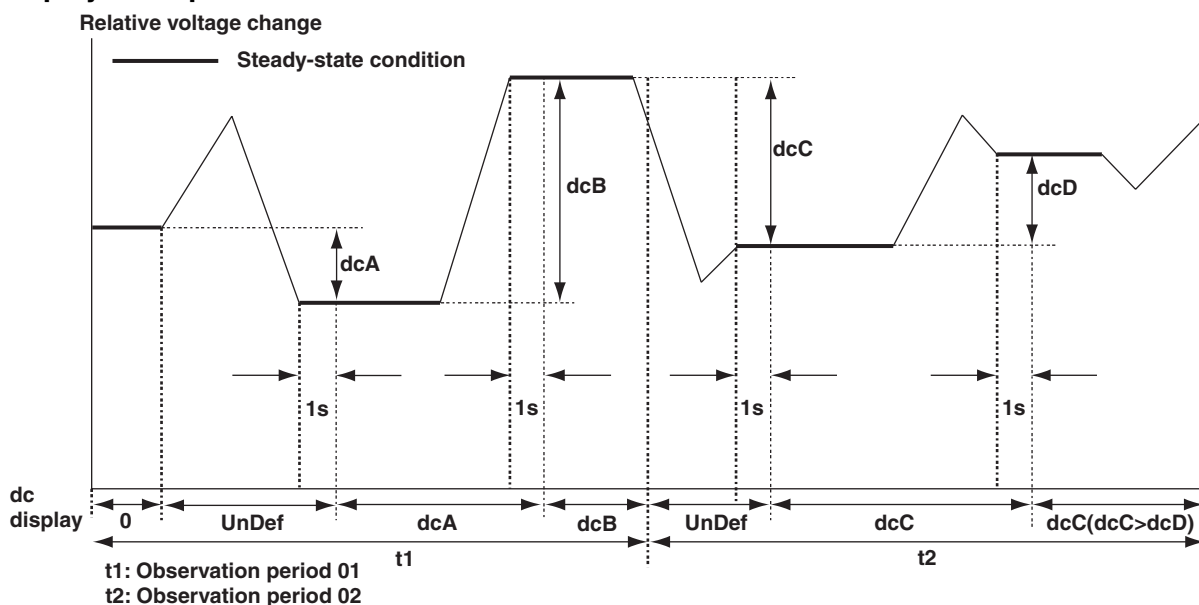

Short-Term Flicker Value Pst

The method using the flicker meter is standard in IEC61000-3-3. For details on the flicker meter, see IEC61000-4-15. The normal observation period of Pst is 10 minutes.

Long-Term Flicker Value Plt

The long-term flicker value is normally determined from 12 Pst values using the equation below. The normal observation period is 2 hours. If the number of observation periods is less than constant N (12) in the calculating equation, the Plt values that are not observed are computed as 0.0.

$$Plt = \sqrt[3]{\frac{Pst_1^3 + Pst_2^3 + \dots + Pst_{12}^3}{12}}$$

Pst₁ :Pst of the first 10 minutes

Pst₂ :Pst of the second 10 minutes

:

Pst₁₂:Pst of the 12th 10 minutes

12.1 Voltage Fluctuation and Flicker Measurement Function

- **Limitations on the Setting Changes and Execution of Operations in Voltage Fluctuation and Flicker Measurement Mode**

There are some functions whose settings cannot be changed in voltage fluctuation and flicker measurement mode as shown below.

Setup Item	Flicker Measurement Status				
	Reset	Initializing	Ready	Start	Complete
Flicker measurement					
Measurement method	Yes	View	View	View	View
Measurement conditions	Yes	View	View	View	View
Initialize	Yes	No	Yes	No	No
Measurement start	No	No	Yes	No	No
Reset	Yes	Yes	Yes	Yes	Yes
Judge ^{*1}	No	No	Yes	No	No
Re-measure ¹	No	No	Yes	No	No
Display element	Yes	Yes	Yes	Yes	Yes
Judgement conditions	Yes	View	View	View	Yes
Measurement mode	Yes	No	No	No	No
Wiring and compensation					
Wiring system	Yes	View	View	View	View
Independent setting of elements	Yes	View	View	View	View
Efficiency and compensation	View	View	View	View	View
Voltage/current range	Yes	No	No	No	No
Auto range	No	No	No	No	No
Sensor transformation ratio	Yes	View	View	View	View
Crest factor	Yes	View	View	View	View
Voltage/current mode	No	No	No	No	No
Scaling	Yes	View	View	View	View
Filter	Yes	View	View	View	View
Averaging	No	No	No	No	No
Synchronization source	No	No	No	No	No
Measurement and computation ([MEASURE])	No	No	No	No	No
Frequency measurement	Yes	View	View	View	View
Cursor	Disabled	Disabled	Disabled	Disabled	Disabled
NULL	No	No	No	No	No
Motor evaluation	No	No	No	No	No
Harmonic measurement	No	No	No	No	No
Display item [U/I/P] to [USER] [ELEMENT]	Disabled Yes	Disabled Yes	Disabled Yes	Disabled Yes	Disabled Yes
Data update rate	No	No	No	No	No
Hold	Yes	Yes	Yes	Yes	Yes
Single measurement (display update)	Yes	Yes	Yes	Yes	Yes
Zero-level compensation	Yes	No	No	No	No
Integration	No	No	No	No	No
File operation	Yes	Yes	Yes	Yes	Yes
Set or execute the screen image storage	Yes	Yes	Yes	Yes	Yes
Set or execute the storage operation	No	No	No	No	No
Set or execute the print operation	Yes	Yes	Yes	Yes	Yes
Miscellaneous ([MISC])	Yes	Yes	Yes	Yes	Yes
Help	Yes	Yes	Yes	Yes	Yes

Yes: The settings can be changed, and the function can be executed.

No: The settings cannot be changed, and the function cannot be executed.

View: The settings can be viewed but cannot be changed, and the function cannot be executed.

Disabled: Does not function.

*1 Measurement of dmax caused by manual switching only

12.2 Setting the Voltage Fluctuation and Flicker Measurement Mode

Procedure

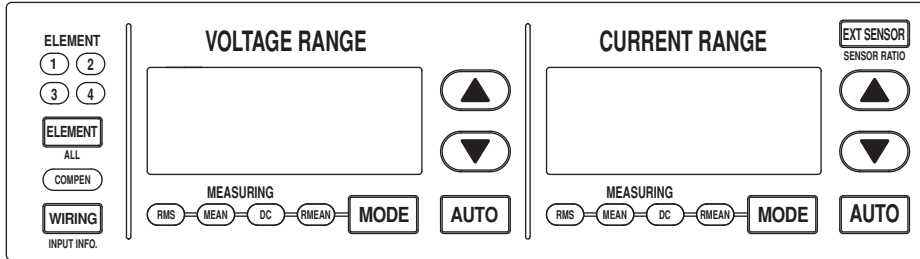

To exit the menu during operation, press **ESC** located above the soft keys.

In the procedural explanation below, the phrase “press the **cursor keys**” may be used. This phrase refers to the procedures for selecting items and entering values and character strings. For details on the procedures, see section 3.14 in the *User's Manual IM760301-01E*.

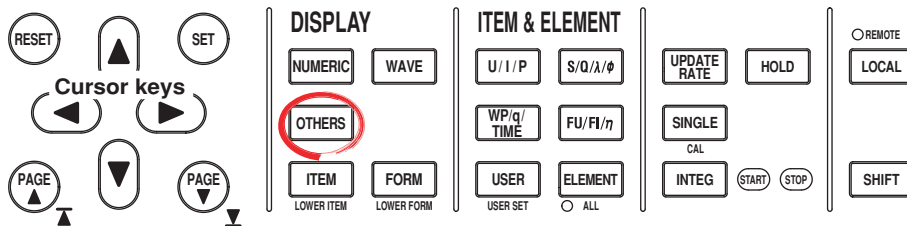

1. Press **OTHERS** to display the Others menu.
2. Press the **Next 1/3** soft key to display the Next 2/3 menu.
3. Press the **Flicker** soft key.

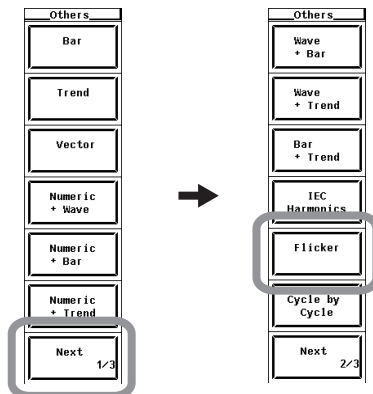

12.2 Setting the Voltage Fluctuation and Flicker Measurement Mode

Explanation

- **Display Related to the Voltage Fluctuation and Flicker Measurement**

The figure below is a display example of normal flicker measurement.

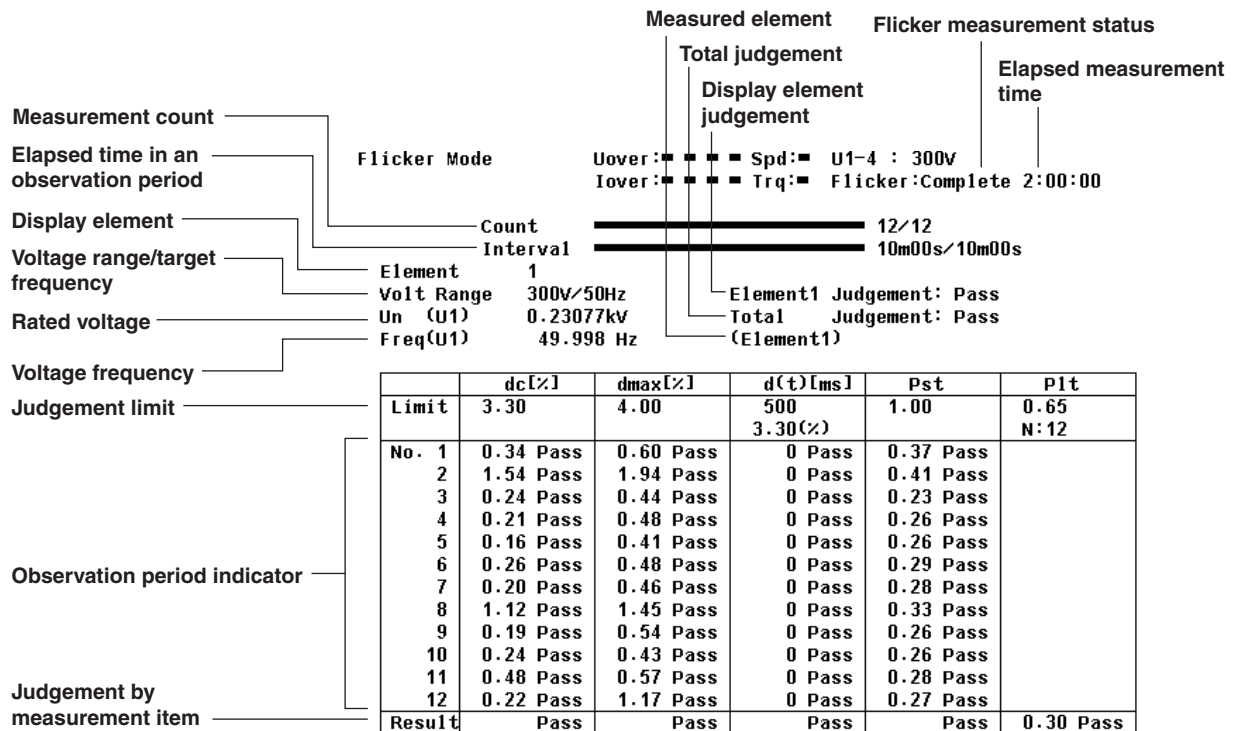

- **Flicker Measurement Status**

The following five flicker measurement statuses are available.

Display	Meaning
Reset	Condition in which the measured value is reset and initialization can be executed.
Initializing	Initializing
Ready	Initialized condition in which measurement can be started.
Start	Measurement in progress. The elapsed time is displayed to the right.
Complete	Complete

- **Connecting to the Harmonic/Flicker Measurement Software**

If you use the Harmonic/Flicker Measurement Software, the WT3000 automatically switches to voltage fluctuation and flicker mode.

- **Limitations on Changing the Measurement Mode**

The WT3000 cannot switch to voltage fluctuation and flicker measurement mode in the following conditions.

- When the master/slave synchronization measurement is set to slave.
- When the integration function is started or stopped.
- When auto print is ON.
- While storage or recall operation is in progress.
- While the storage medium is being accessed.
- While saving waveform sampling data to the storage medium.

12.3 Setting the Measurement Conditions

Procedure

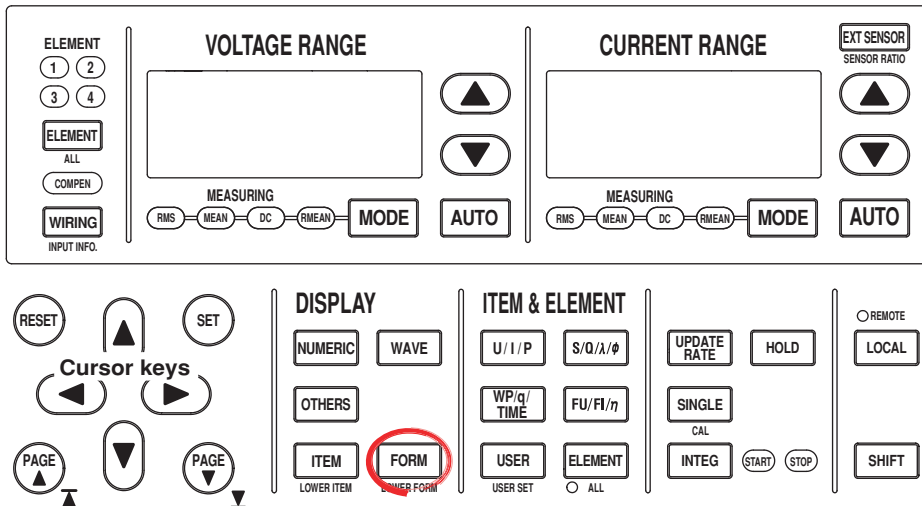

To exit the menu during operation, press **ESC** located above the soft keys.

In the procedural explanation below, the phrase “press the **cursor keys**” may be used. This phrase refers to the procedures for selecting items and entering values and character strings. For details on the procedures, see section 3.14 in the *User's Manual IM760301-01E*.

Check that the flicker measurement status is indicating Reset. If not, set the flicker measurement status to Reset according to the procedure in “Resetting the Voltage Fluctuation and Flicker Measurement” on page 12-19.

1. Press **FORM** to display the Flicker Form menu.
- **Setting the Measurement Method**
 2. Press the **Measurement** soft key to select Flicker (normal flicker measurement) or dmax (measurement of dmax caused by manual switching).

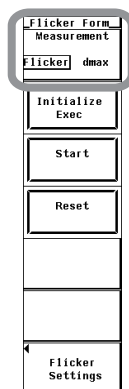

12.3 Setting the Measurement Conditions

- **Setting the Measured Element**

3. Press the **Flicker Settings** soft key to display the Flicker Settings dialog box.
4. Press the **cursor keys** to select the element you want to set from Object.
5. Press **SET**. The button to the left of the selected element is highlighted indicating that voltage fluctuation and flicker measurement will be performed on the element. To remove the element from the measurement, press SET again. The highlighting of the button is cleared.

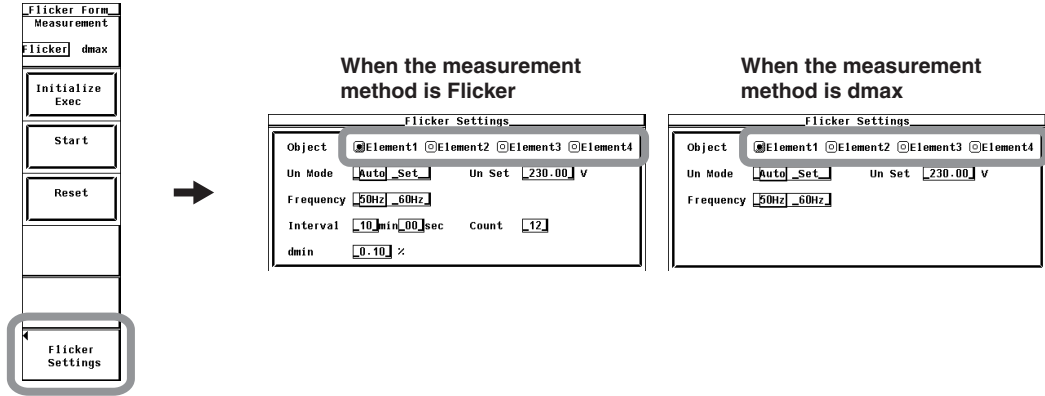

- **Setting the Rated Voltage**

- **Selecting the Assignment Method of the Rated Voltage**

6. Press the **cursor keys** to select Un Mode.
7. Press **SET** to select Auto or Set.
If you select Auto, proceed to step 12.
If you select Set, proceed to step 8.

- **Setting the Predefined Rated Voltage**

(valid when the assignment method is Set)

8. Press the **cursor keys** to select Un Set.
9. Press **SET** to display the entry box.
10. Press the **cursor keys** to set the predefined value.
11. Press **SET** or **ESC** to close the box.

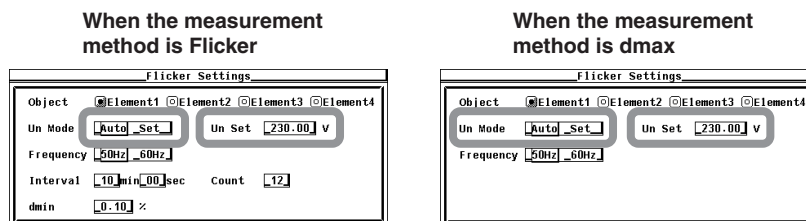

- **Setting the Measurement Target Frequency**

12. Press the **cursor keys** to select Frequency.
13. Press **SET** to select 50 Hz or 60 Hz.

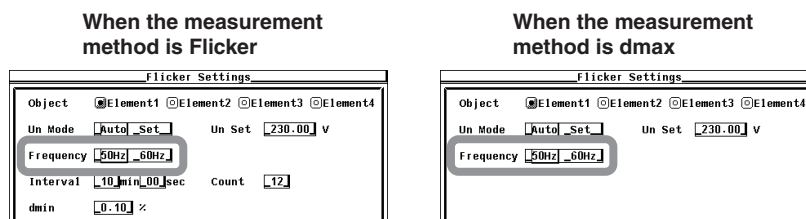

If the measurement method is set to Flicker (normal flicker measurement), set the single observation period, measurement count, and steady-state range according to the procedure below.

• **Setting the Single Observation Period**

14. Press the **cursor keys** to select the min or sec box by Interval.
15. Press **SET** to display the entry box.
16. Press the **cursor keys** to set the minutes or seconds.
17. Press **SET** or **ESC** to close the box.
18. Repeat steps 14 and 17 to enter the minutes and seconds.

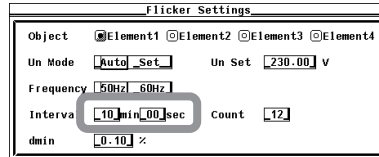

• **Setting the Measurement Count**

19. Press the **cursor keys** to select Count.
20. Press **SET** to display the entry box.
21. Press the **cursor keys** to set the measurement count.
22. Press **SET** or **ESC** to close the box.

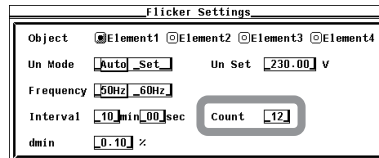

• **Setting the Steady-State Range (dmin: Allowable Range of Relative Voltage Change to Be Considered Steady-State)**

23. Press the **cursor keys** to select dmin.
24. Press **SET**. An entry box appears.
25. Press the **cursor keys** to set the steady-state range.
26. Press **SET** or **ESC** to close the box.

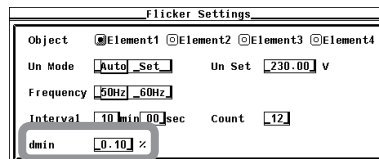

Explanation

For an explanation of the terminology, see section 12.1.

- **Measurement Method**

Select the voltage fluctuation and flicker measurement method from the two methods below.

- Flicker (normal flicker measurement)
Judges the voltage fluctuation and flicker from dc, dmax, d(t), and Pst.
- dmax (measurement of dmax caused by manual switching)
You manually turn the EUT switch ON. The WT3000 measures the voltage fluctuation caused by the inrush current that flows when the power is turned ON, and judges the voltage fluctuation and flicker from the dmax average.

- **Measured element**

Set the element on which to measure the voltage fluctuation and flicker. The installed elements are displayed as possible targets.

- **Rated Voltage**

You can select the assignment method of the rated voltage.

- Auto
Automatically retrieves the measured voltage at the start of the voltage fluctuation and flicker measurement as the rated voltage.
- Manual
You can set the rated voltage in the range of 0.01 to 999.99 V.

- **Measurement Target Frequency**

You can set the measurement target frequency to 50 Hz or 60 Hz.

Set the measurement source frequency appropriately as the transfer function of the flicker meter and other parameters change accordingly.

Note

The limit is defined only for 50 Hz. It is not defined for 60 Hz.

If the measurement method is set to Flicker (normal flicker measurement), you must set the single observation period, measurement count, and steady-state range.

- **Single Observation Period**

You can set the single observation period of short-term flicker value Pst in unit of minutes and seconds in the following range.

00:30 to 15:00 (only even values can be specified for the seconds)

- **Measurement Count**

You can set the measurement count of short-term flicker value Pst in the range of 1 to 99.

- **Steady-State Range (dmin: Allowable Range of Relative Voltage Change to Be Considered Steady-State)**

You can set steady-state range dmin in the range of 0.10 to 9.99%.

Note

You can change the measurement conditions only when the flicker measurement status is Reset.

12.4 Setting the Judgement Conditions

Procedure

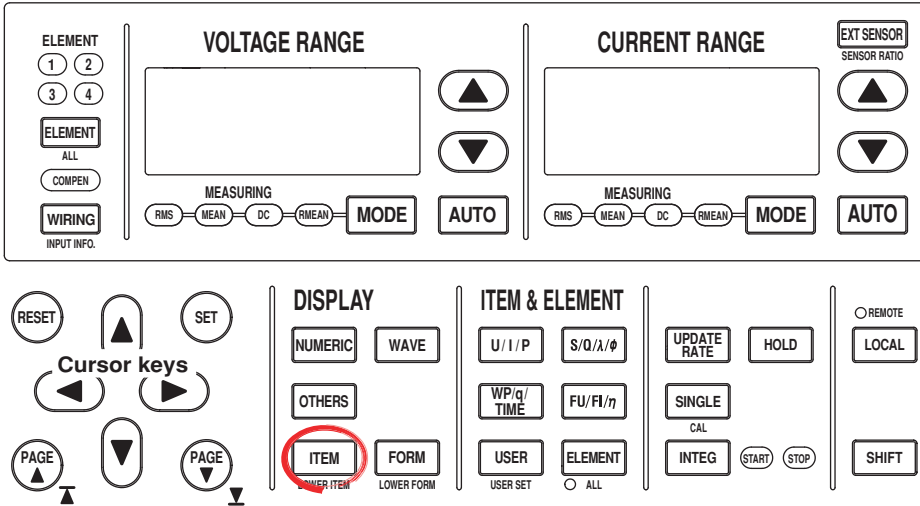

To exit the menu during operation, press **ESC** located above the soft keys.

In the procedural explanation below, the phrase “press the **cursor keys**” may be used. This phrase refers to the procedures for selecting items and entering values and character strings. For details on the procedures, see section 3.14 in the *User's Manual IM760301-01E*.

Check that the flicker measurement status is indicating Reset. If not, set the flicker measurement status to Reset according to the procedure in “Resetting the Voltage Fluctuation and Flicker Measurement” on page 12-19.

1. Press **ITEM** to display the Flicker Items menu.
2. Press the **Limit Settings** soft key to display the Limit Settings dialog box.

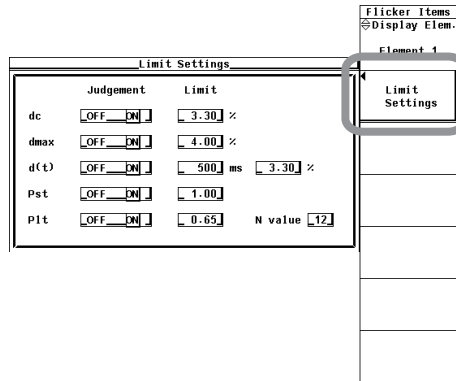

12.4 Setting the Judgement Conditions

If you set the measurement method to Flicker (normal flicker measurement) in step 2 of section 12.3, proceed to step 3. If you set the measurement method to d_{max} (measurement of d_{max} caused by manual switching), proceed to step 9, and only set the judgement condition on maximum relative voltage change d_{max} (steps 9 to 14).

- **Setting the Judgement Conditions for the Relative Steady-State Voltage Change dc**
 - **Turning ON/OFF the Judgement of Relative Steady-State Voltage Change dc**

3. Press the **cursor keys** to select Judgement by dc.
4. Press **SET** to select ON (judge) or OFF (not judge).

- **Setting the Limit on Relative Steady-State Voltage Change dc**
(Valid when ON (judge) is selected in step 4)

5. Press the **cursor keys** to select Limit by dc.
6. Press **SET** to display the entry box.
7. Press the **cursor keys** to set the limit.
8. Press **SET** or **ESC** to close the box.

	Judgement	Limit
dc	OFF [ON]	3.30 %
d_{max}	OFF [ON]	4.00 %
$d(t)$	OFF [ON]	500 ms 3.30 %
Pst	OFF [ON]	1.00
P1t	OFF [ON]	0.65 N value 12

- **Setting the Judgement Conditions of Maximum Relative Voltage Change d_{max}**
 - **Turning ON/OFF the Judgement of Maximum Relative Voltage Change d_{max}**

9. Press the **cursor keys** to select Judgement by d_{max} .
10. Press **SET** to select ON (judge) or OFF (not judge).

- **Setting the Limit on Maximum Relative Voltage Change d_{max}**
(Valid when ON (judge) is selected in step 10)

11. Press the **cursor keys** to select Limit by d_{max} .
12. Press **SET** to display the entry box.
13. Press the **cursor keys** to set the limit.
14. Press **SET** or **ESC** to close the box.

	Judgement	Limit
dc	OFF [ON]	3.30 %
d_{max}	OFF [ON]	4.00 %
$d(t)$	OFF [ON]	500 ms 3.30 %
Pst	OFF [ON]	1.00
P1t	OFF [ON]	0.65 N value 12

- **Setting the Judgement Conditions for Period during Which Relative Voltage Change Exceeds the Threshold Level $d(t)$ in a Single Voltage Fluctuation Period**

- **Turning ON/OFF the Judgement of Period during Which Relative Voltage Change Exceeds the Threshold Level $d(t)$**

15. Press the **cursor keys** to select Judgement by $d(t)$.
16. Press **SET** to select ON (judge) or OFF (not judge).

- **Setting the Limit on Period during Which Relative Voltage Change Exceeds the Threshold Level $d(t)$**
(Valid when ON (judge) is selected in step 16)

17. Press the **cursor keys** to select the left Limit box (ms) by $d(t)$.
18. Press **SET** to display the entry box.
19. Press the **cursor keys** to set the limit.
20. Press **SET** or **ESC** to close the box.

- **Setting the Threshold Level**

(Valid when ON (judge) is selected in step 16)

21. Press the **cursor keys** to select the right Limit box (ms) by d(t).
22. Press **SET** to display the entry box.
23. Press the **cursor keys** to set the threshold level.
24. Press **SET** or **ESC** to close the box.

	Judgement	Limit
dc	OFF ON	3.30 ✕
dmax	OFF ON	4.00 ✕
d(t)	OFF ON	500 ms 3.30 ✕
Pst	OFF ON	1.00
PIt	OFF ON	0.65 N value 12

- **Setting the Judgement Conditions for Short-Term Flicker Value Pst**

- **Turning ON/OFF the Judgement of Short-Term Flicker Value Pst**

25. Press the **cursor keys** to select Judgement by Pst.
26. Press **SET** to select ON (judge) or OFF (not judge).

- **Setting the Limit on Short-Term Flicker Value Pst**

(Valid when ON (judge) is selected in step 26)

27. Press the **cursor keys** to select Limit by Pst.
28. Press **SET** to display the entry box.
29. Press the **cursor keys** to set the limit.
30. Press **SET** or **ESC** to close the box.

	Judgement	Limit
dc	OFF ON	3.30 ✕
dmax	OFF ON	4.00 ✕
d(t)	OFF ON	500 ms 3.30 ✕
Pst	OFF ON	1.00
PIt	OFF ON	0.65 N value 12

- **Setting the Judgement Conditions for Long-Term Flicker Value PIt**

- **Turning ON/OFF the Judgement of Long-Term Flicker Value PIt**

31. Press the **cursor keys** to select Judgement by PIt.
32. Press **SET** to select ON (judge) or OFF (not judge).

- **Setting the Limit on Long-Term Flicker Value PIt**

(Valid when ON (judge) is selected in step 32)

33. Press the **cursor keys** to select Limit by PIt.
34. Press **SET** to display the entry box.
35. Press the **cursor keys** to set the limit.
36. Press **SET** or **ESC** to close the box.

- **Setting Constant N of the Calculating Equation of Long-Term Flicker Value PIt**

37. Press the **cursor keys** to select N value by PIt.
38. Press **SET** to display the entry box.
39. Press the **cursor keys** to set the constant.
40. Press **SET** or **ESC** to close the box.

12.4 Setting the Judgement Conditions

Judgement	Limit
dc	3.30 %
dmax	4.00 %
d(t)	500 ms 3.30 %
Pst	1.00
P1t	0.65
	N valu 12

Explanation

For an explanation of the terminology, see section 12.1.

- **Judgement Conditions for Relative Steady-State Voltage Change dc**
 - **Turning ON/OFF the Judgement of Relative Steady-State Voltage Change dc**

You can select whether to include relative steady-state voltage change dc in the flicker measurement judgement.

 - ON: Include dc.
 - OFF: Not include dc.
 - **Limit on Relative Steady-State Voltage Change dc**

You can set the limit in the range of 1.00 to 99.99%.
- **Judgement Conditions for Maximum Relative Voltage Change dmax**
 - **Turning ON/OFF the Judgement of Maximum Relative Voltage Change dmax**

You can select whether to include maximum relative voltage change dmax in the flicker measurement judgement.

 - ON: Include dmax.
 - OFF: Not include dmax.
 - **Limit on Maximum Relative Voltage Change dmax**

You can set the limit in the range of 1.00 to 99.99%.
- **Judgement Conditions for Time d(t) during Which the Relative Voltage Change Exceeds the Threshold Level**
 - **Turning ON/OFF the Judgement of Time d(t) during Which the Relative Voltage Change Exceeds the Threshold Level**

You can select whether to include time d(t) during which the relative voltage change exceeds the threshold level in the flicker measurement judgement.

 - ON: Include d(t).
 - OFF: Not include d(t).
 - **Limit on Time d(t) during Which the Relative Voltage Change Exceeds the Threshold Level**

You can set the limit in the range of 1 to 99999 ms.
 - **Threshold Level**

You can set the threshold level in the range of 1.00 to 99.99%.
- **Judgement Conditions for Short-Term Flicker Value Pst**
 - **Turning ON/OFF the Judgement of Short-Term Flicker Value Pst**

You can select whether to include short-term flicker value Pst in the flicker measurement judgement.

 - ON: Include Pst.
 - OFF: Not include Pst.

- **Limit on Short-Term Flicker Value Pst**
You can set the limit in the range of 0.10 to 99.99.
- **Judgement Conditions for Long-Term Flicker Value Plt**
 - **Turning ON/OFF the Judgement of Long-Term Flicker Value Plt**
You can select whether to include long-term flicker value Plt in the flicker measurement judgement.
 - ON: Include Plt.
 - OFF: Not include Plt.
- **Limit on Long-Term Flicker Value Plt**
You can set the limit in the range of 0.10 to 99.99.
- **Constant N of the Calculating Equation of Long-Term Flicker Value Plt**
You can set constant N in the range of 1 to 99.

Note

The long-term flicker value (Plt) is computed using the following equation.

$$Plt = \sqrt[3]{\frac{\sum_{i=2}^{Count} Psti^3}{N}}$$

The variable Count in the equation is the measurement count of short-term flicker value (Pst) that is set in section 12.3).

The variable N in the equation is the constant of the calculating equation of long-term flicker value (Plt).

In general, set Count and N to the same value.

If N is set greater than Count, the short-term flicker value is measured the number of times specified by Count. The short-term flicker values that are not measured are substituted with zeroes in the above equation to calculate the long-term flicker value (Plt). N is set greater than Count such as when the measured source automatically stops within the specified observation time.

Note

You can change the judgement conditions only when the flicker measurement status is Reset or Complete.

12.5 Executing the Normal Voltage Fluctuation and Flicker Measurement

Procedure

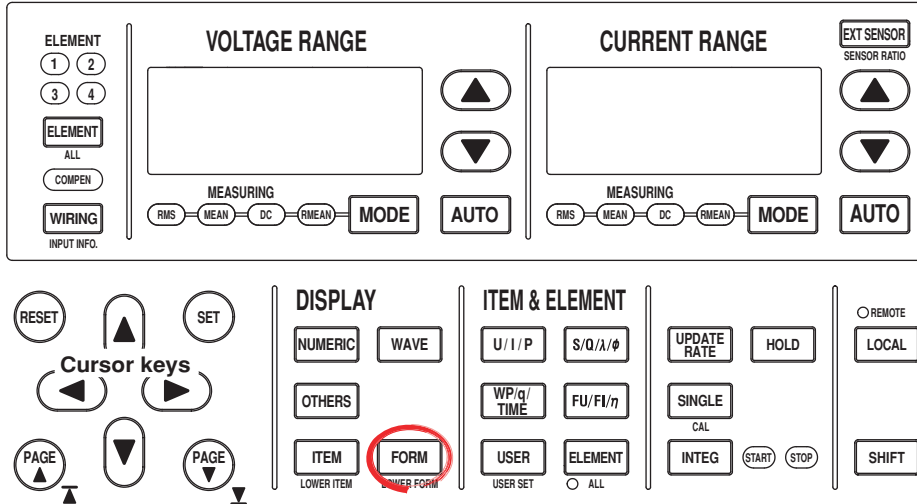

To exit the menu during operation, press **ESC** located above the soft keys.

In the procedural explanation below, the phrase “press the **cursor keys**” may be used. This phrase refers to the procedures for selecting items and entering values and character strings. For details on the procedures, see section 3.14 in the *User's Manual IM760301-01E*.

Check that the flicker measurement status is indicating Reset. If not, set the flicker measurement status to Reset according to the procedure in “Resetting the Voltage Fluctuation and Flicker Measurement” on page 12-19.

1. Set the measurement method to flicker according to the procedure given in “Setting the Measurement Conditions” in section 12.3.
 2. Set the measurement range, input filter, scaling, etc. (see chapter 4 in the *User's Manual IM760301-01E*).
 3. Apply the voltage of the power supply to be measured to the WT3000.
- **Initializing the Voltage Fluctuation and Flicker Measurement**
 4. Press **FORM** to display the Flicker Form menu.
 5. Press the **Initialize Exec** soft key to start the initialization. The flicker measurement status at the upper right section of the screen indicates Initializing. When the initialization is complete, the flicker measurement status changes to Ready.

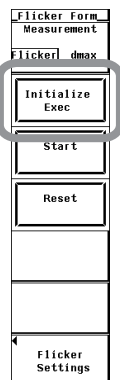

• **Aborting the Initialization**

6. Press the **Reset** soft key. An Alert dialog box appears.
7. Press the **cursor keys** to select OK.
8. Press **SET** to abort the initialization. The flicker measurement status indicates Reset. To continue the initialization, select Cancel in step 7 and press **SET**.

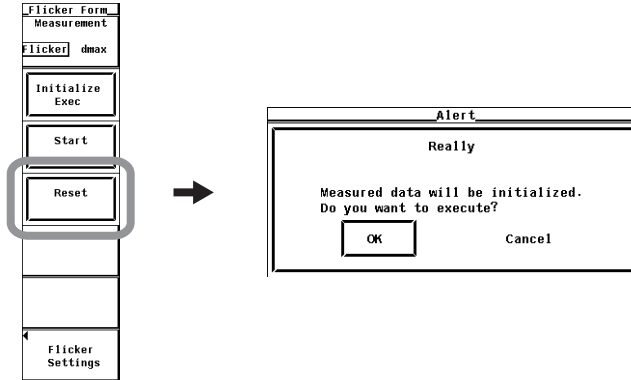

• **Starting the Voltage Fluctuation and Flicker Measurement**

9. Press the **Start** soft key when the flicker measurement status is Ready. The voltage fluctuation and flicker measurement starts. The flicker measurement status indicates Start.

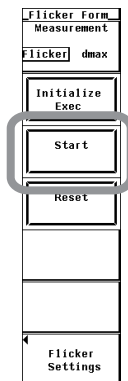

• **Holding the Voltage Fluctuation and Flicker Measurement**

10. Press **HOLD**. The HOLD key illuminates, and the display is held. The voltage fluctuation and flicker measurement continues.

• **Releasing the Hold Operation**

11. Press **HOLD** while the display is held. The HOLD key turns OFF, and the display is updated. In the hold condition, the display can be updated to the most recent value by carrying out single measurements (by pressing SINGLE).

• **Aborting the Voltage Fluctuation and Flicker Measurement**

12. Press the **Reset** soft key. An Alert dialog box appears.
13. Press the **cursor keys** to select OK.
14. Press **SET**. The voltage fluctuation and flicker measurement is aborted. The measured data and judgement up to that point are discarded. The flicker measurement status indicates Reset. To continue the voltage fluctuation and flicker measurement, select Cancel in step 13 and press **SET**.

12.5 Executing the Normal Voltage Fluctuation and Flicker Measurement

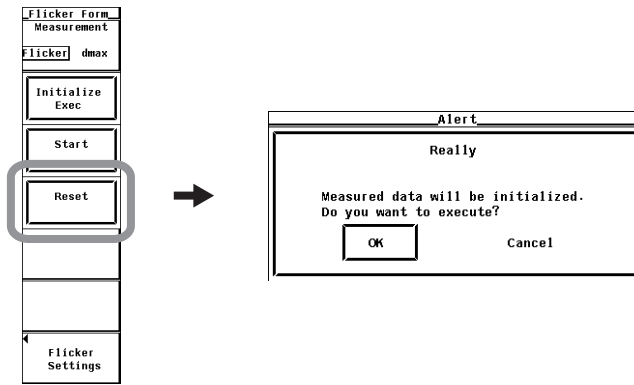

- **Completing the Voltage Fluctuation and Flicker Measurement and Displaying the Judgement**

15. When the measurement of all observation periods is complete, the voltage fluctuation and flicker measurement automatically stops. The flicker measurement status indicates Complete.

- **Changing the Judgement Conditions and Re-judging the Measured Data**

16. When the flicker measurement status is indicating Complete, change the judgement conditions according to the procedure given in "Setting the Judgement Conditions" in section 12.4. When you change the judgement conditions, the measured voltage fluctuation and flicker data is re-judged, and the judgement is updated.

- **Switching the Element for Displaying the Measurement/Judgement Data**

There are two ways to switch the element for displaying the measurement and judgement data as described below.

- **Changing Using the Function Select Keys**

17. Press **ELEMENT** to set the element to be displayed.
The element to be displayed switches in order as in 1, 2, ..., 1.

- **Selecting from the Menu**

17. Press **ITEM** to display the Flicker Items menu.
18. Press the **cursor keys** to set the element to be displayed.

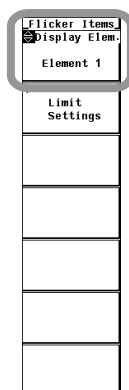

- **Page Scrolling the Screen (Only When the Measurement Count Exceeds 12)**

18. Press **PAGE ▼** or **PAGE ▲** to scroll the page.

- Press **PAGE ▼** to display the next page.
- Press **PAGE ▲** to display the previous page.

- **Jumping to the Last or First Page (Only When the Measurement Count Exceeds 12)**

19. Press SHIFT+PAGE \blacktriangledown (\blacktriangledown) or SHIFT+PAGE \blacktriangle (\blacktriangle).
 - Press SHIFT+PAGE \blacktriangle (\blacktriangle) to display the last page.
 - Press SHIFT+PAGE \blacktriangledown (\blacktriangledown) to display the first page.

- **Resetting the Voltage Fluctuation and Flicker Measurement**

20. Press the **Reset** soft key. An Alert dialog box appears.
21. Press the **cursor keys** to select OK.
22. Press **SET**. The voltage fluctuation and flicker measurement is reset. The measured data and judgement up to that point are discarded. The flicker measurement status indicates Reset. To not reset, select Cancel in step 21 and press **SET**.

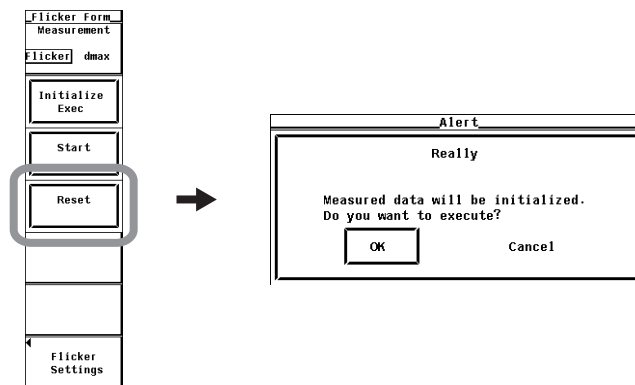

12.5 Executing the Normal Voltage Fluctuation and Flicker Measurement

Explanation

• Display during Measurement

The figure below is a display example of normal flicker measurement in progress.

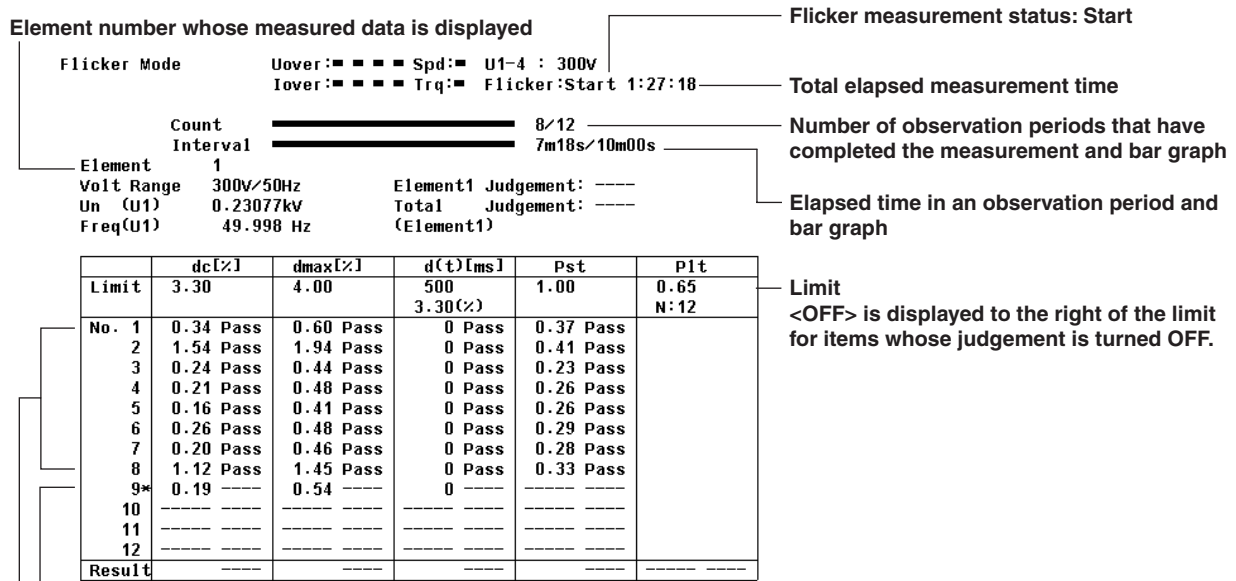

Observation period being measured

- An asterisk is displayed to the right of the number. The dc, dmax, and d(t) columns of that line show the maximum values in the observation period.
- The judgement of items whose judgement is turned OFF shows blank.

Observation periods that have finished the measurement

- The final values of dc, dmax, and d(t) are compared with the respective limits, and the judgement (pass or fail) is displayed to the right of the final value.
- The short-term flicker value, Pst, is calculated, compared to the limit, and the judgement (pass or fail) is displayed.

• Judgement Display When the Measurement Is Complete

The figure below is a display example when the normal flicker measurement is complete.

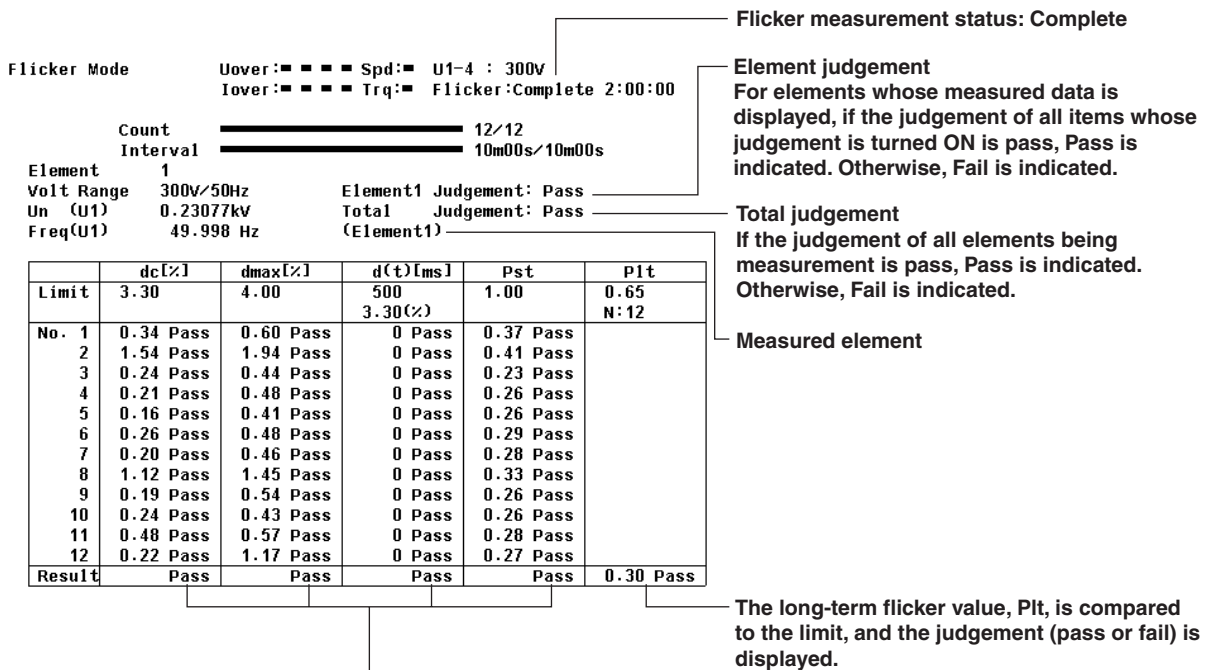

If the judgement of dc, dmax, d(t), and Pst is pass for all observation periods, Pass is indicated. Otherwise, Fail is indicated.

- **Initializing the Voltage Fluctuation and Flicker Measurement**
 - The initialization takes approximately 30 s.
 - Rms voltage U_n and voltage frequency F_{req} are updated every 2 s while the initialization is in progress in the same manner as when the voltage fluctuation and flicker measurement is reset.
 - Keep the voltage of the power supply to be measured in steady-state condition while the initialization is in progress.
- **Rated Voltage U_n and Voltage Frequency F_{req}**
 - If the assignment method of rated voltage is Auto, rms voltage at the start of measurement is used as rated voltage U_n . The measured data is calculated with respect to rated voltage U_n .
 - If the assignment method of rated voltage is Set, the rated voltage setting is displayed as $U_n(\text{Set})$.
 - Rated voltage U_n and voltage frequency F_{req} are fixed to the first measured values after the flicker measurement is started and are not updated.
- **Switching the Element for Displaying the Measurement Data**

You can select the element from below. The selectable items vary depending on the installed elements.
Element1, Element2, Element3, and Element4

Note

If an element that is not being measured is assigned to a display target element, <OFF> is displayed by the element number, and all measured data and judgement are displayed as blank.

- **Page Scrolling the Screen**

A single page displays a list of measured data and judgements for 12 observation periods. If the measurement count exceeds 12, the data is displayed on multiple pages. In this case, you can page scroll to switch the displayed page. Page scroll is possible only when the flicker measurement status is indicating Reset or Complete.
- **Resetting the Voltage Fluctuation and Flicker Measurement**

To initialize and restart the measurement, execute reset after the voltage fluctuation and flicker measurement is complete and the flicker measurement status is indicating Complete. You cannot initialize or start the measurement in the Complete status. Reset the voltage fluctuation and flicker measurement to change the following settings.

 - Measurement conditions (chapter 4 in the *User's Manual IM760301-01E*)
 - Measurement conditions of the voltage fluctuation and flicker measurement (section 12.3)

12.5 Executing the Normal Voltage Fluctuation and Flicker Measurement

• Flow Chart of the Normal Flicker Measurement

(Transition Diagram of the Flicker Measurement Status)

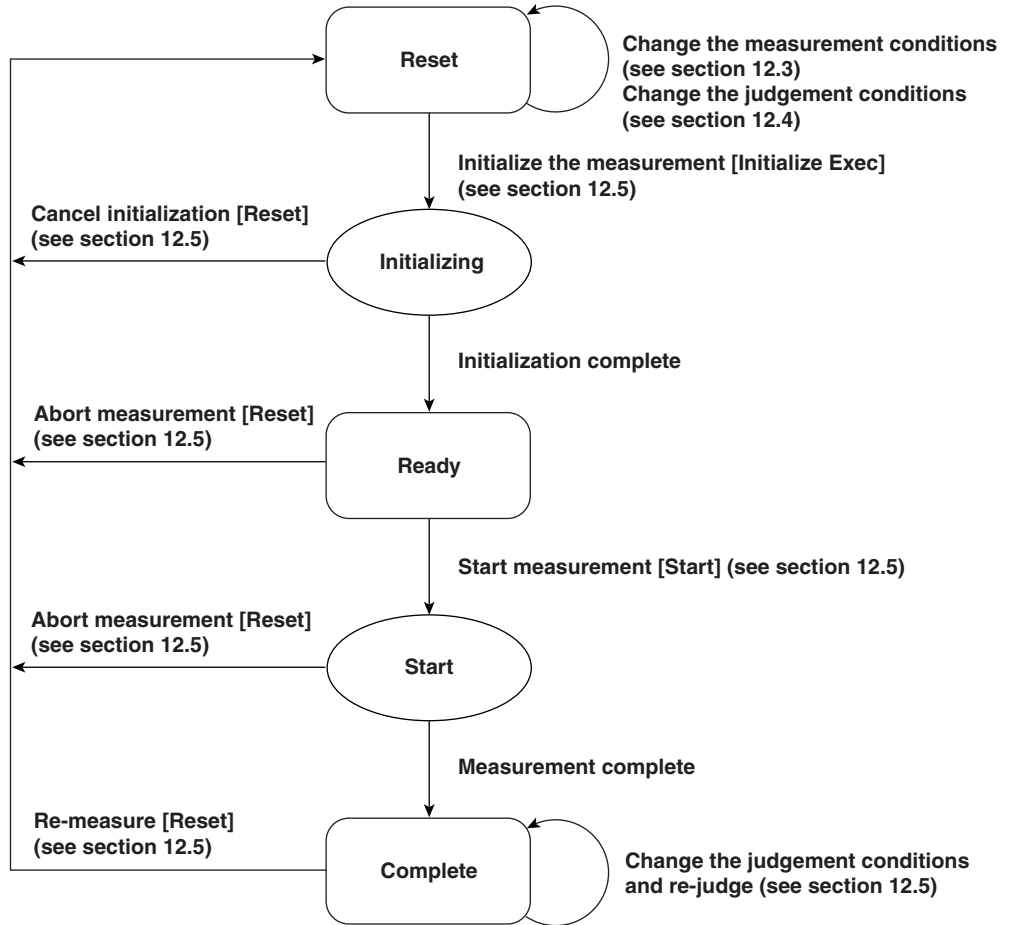

Reference sections are indicated in parentheses.
Soft keys that you operate are indicated in brackets.

12.6 Executing the Measurement of dmax Caused by Manual Switching

Procedure

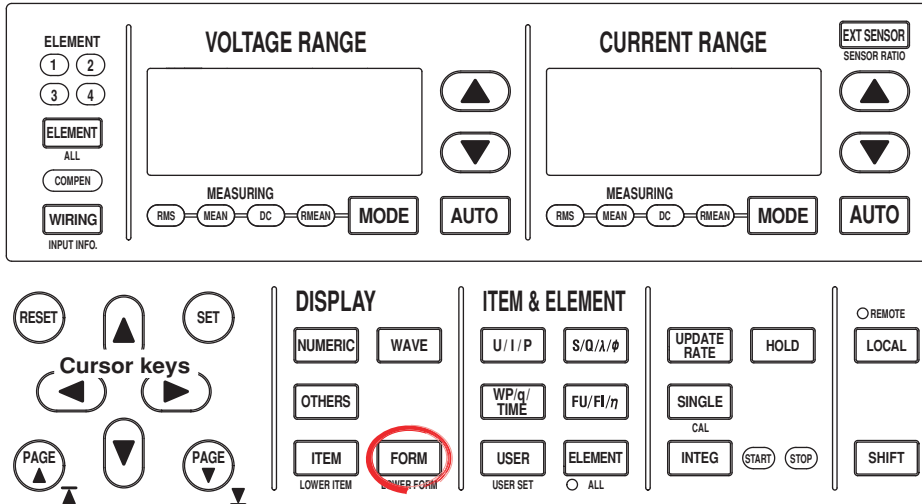

To exit the menu during operation, press **ESC** located above the soft keys.

In the procedural explanation below, the phrase “press the **cursor keys**” may be used. This phrase refers to the procedures for selecting items and entering values and character strings. For details on the procedures, see section 3.14 in the *User’s Manual IM760301-01E*.

Check that the flicker measurement status is indicating Reset. If not, set the flicker measurement status to Reset according to the procedure in “Resetting the Voltage Fluctuation and Flicker Measurement” on page 12-19.

1. Set the measurement method to dmax according to the procedure given in “Setting the Measurement Conditions” in section 12.3.
 2. Set the measurement range, input filter, scaling, etc. (see chapter 4 in the *User’s Manual IM760301-01E*).
 3. Apply the voltage of the power supply to be measured to the WT3000. Leave the EUT turned OFF.
- **Initializing the Measurement of dmax Caused by Manual Switching**
 4. Press **FORM** to display the Flicker Form menu.
 5. Press the **Initialize Exec** soft key to start the initialization. The flicker measurement status at the upper right section of the screen indicates Initializing. When the initialization is complete, the flicker measurement status changes to Ready.

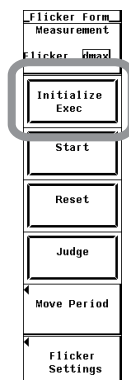

12.6 Executing the Measurement of dmax Caused by Manual Switching

- **Aborting the Initialization**

6. Press the **Reset** soft key. An Alert dialog box appears.
7. Press the **cursor keys** to select OK.
8. Press **SET** to abort the initialization. The flicker measurement status indicates Reset. To continue the initialization, select Cancel in step 7 and press **SET**.

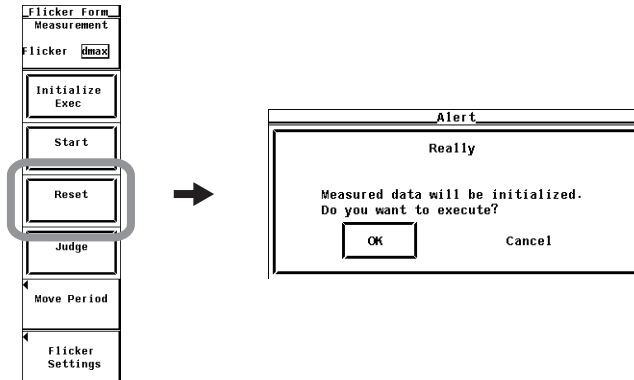

- **Starting the Measurement of dmax Caused by Manual Switching**

9. Press the **Start** soft key when the flicker measurement status is Ready. The measurement of dmax caused by manual switching starts. The flicker measurement status indicates Start.

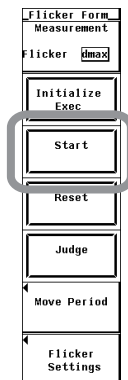

10. Turn the EUT ON to achieve normal operation. Operate the EUT in the normal condition as long as possible in the measurement period of one observation period (1 minute).
11. Turn the EUT OFF before the measurement of one observation period (1 minute) completes. When the measurement of one observation period is complete, the flicker measurement status changes to Ready.
12. Repeat steps 9 to 11 to measure dmax 24 times.

Note

Repeat the measurement after the device that reduces dmax cools to the ambient temperature.

- **Holding the Measurement of dmax Caused by Manual Switching**

13. Press **HOLD**. The HOLD key illuminates, and the display is held. The measurement of dmax caused by manual switching continues.

- **Releasing the Hold Operation**

14. Press **HOLD** while the display is held. The HOLD key turns OFF, and the display is updated. In the hold condition, the display can be updated to the most recent value by carrying out single measurements (by pressing SINGLE).

• **Re-measuring the Measurement of dmax Caused by Manual Switching**

If a measurement of a given observation period is not performed correctly, you can change the observation period to be measured by carrying out to the procedure below and redo the measurement.

15. Press the **Move Period** soft key to display the Move Period menu.
16. Press the **cursor keys** to set No. (Move to) of the observation period you want to re-measure.
17. Press the **Move Period Exec** soft key. The asterisk moves by the observation period number specified in step 16.
18. Press **ESC** to close the Move Period menu.
19. Carry out steps 9 to 11 to measure dmax.
If you start the re-measurement, the measurement count and graph display shown in Count decrease by one. In addition, the total elapsed measurement time that is displayed to the right of the flicker measurement status decreases by one observation period. When the re-measurement is complete, the asterisk moves to the next observation period number of the observation period in which the measurement is completed.
20. If you want to continue with the measurement, repeat steps 9 to 11. To change the observation period to be measured, return to step 15.

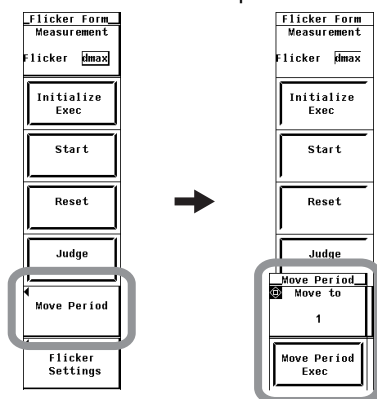

• **Aborting the Measurement of dmax Caused by Manual Switching**

21. Press the **Reset** soft key. An Alert dialog box appears.
22. Press the **cursor keys** to select OK.
23. Press **SET**. The measurement of dmax caused by manual switching is aborted. The measured data and judgement up to that point are discarded. The flicker measurement status indicates Reset. To continue the measurement of dmax caused by manual switching, select Cancel in step 22 and press **SET**.

• **Completing the Measurement of dmax Caused by Manual Switching and Displaying the Judgement**

24. Check that the measurement of all observation periods (24) is complete, and that the dmax data of each observation period is displayed.
25. Press the **Judge** soft key. The dmax data of all observation periods is confirmed, and the measurement of dmax caused by manual switching is complete. The flicker measurement status indicates Complete, and the judgement is displayed.

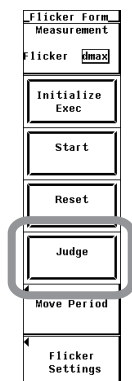

12.6 Executing the Measurement of dmax Caused by Manual Switching

- **Re-judging the Measurement of dmax Caused by Manual Switching**
 26. When the flicker measurement status is indicating Complete, change the judgement conditions according to the procedure given in “Setting the Judgement Conditions” in section 12.4. When you change the judgement conditions, the measured dmax data is re-judged, and the judgement is updated.
- **Switching the Element for Displaying the Measurement/Judgement Data**

There are two ways to switch the element for displaying the measurement and judgement data as described below.

 - **Changing Using the Function Select Keys**
 27. Press **ELEMENT** to set the element to be displayed.
The element to be displayed switches in order as in 1, 2, ..., 1.
 - **Selecting from the Menu**
 27. Press **ITEM** to display the Flicker Items menu.
 28. Press the **cursor keys** to set the element to be displayed.

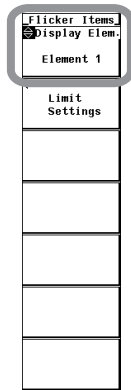

- **Resetting the Measurement of dmax Caused by Manual Switching**
 29. Press the **Reset** soft key. An Alert dialog box appears.
 30. Press the **cursor keys** to select OK.
 31. Press **SET**. The measurement of dmax caused by manual switching is reset.
The measured data and judgement up to that point are discarded. The flicker measurement status indicates Reset. To not reset, select Cancel in step 30 and press **SET**.

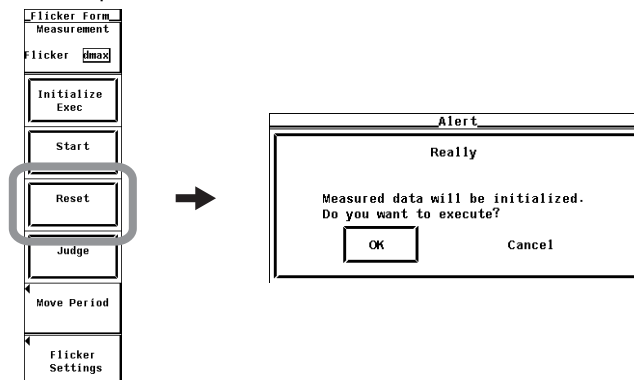

Explanation

• **Display during Measurement**

The figure below is a display example of the measurement of dmax caused by manual switching in progress.

Element number whose measured data is displayed

Flicker Mode Uover: ■■■■ Spd: ■ U1-4 : 300V
 Iover: ■■■■ Trq: ■ Flicker:Start 0:05:08

Count ██████████ 5/24
 Interval ██████████ 0m08s/1m00s

Element 1
 Volt Range 300V/50Hz Element1 Judgement: ----
 Un (U1) 0.23005kV Total Judgement: ----
 Freq(U1) 49.984 Hz (Element1)

Flicker measurement status: Start
 Total elapsed measurement time
 Number of observation periods that have completed the measurement and bar graph
 Elapsed time in an observation period and bar graph

No.	dmax[%]	No.	dmax[%]
1	0.48	13	----
2	0.75 max	14	----
3	0.37	15	----
4	0.34 min	16	----
5	0.50	17	----
6*	0.28	18	----
7	----	19	----
8	----	20	----
9	----	21	----
10	----	22	----
11	----	23	----
12	----	24	----
Limit		4.00	
Result (Average dmax)		0.45 ----	

Observation period being measured

An asterisk is displayed to the right of the number. The dmax columns of that line show the maximum values in the observation period.

If the instantaneous value every 2 s exceeds the maximum value, the value is updated.

Observation periods that have finished the measurement

For the dmax values up to the current observation period, max and min are indicated to the right of the maximum and minimum dmax values, respectively.

• **Judgement Display When the Measurement Is Complete**

The figure below is a display example when the measurement of dmax caused by manual switching is complete.

Flicker Mode Uover: ■■■■ Spd: ■ U1-4 : 300V
 Iover: ■■■■ Trq: ■ Flicker:Complete 0:24:00

Count ██████████ 24/24
 Interval ██████████ 1m00s/1m00s

Element 1
 Volt Range 300V/50Hz Element1 Judgement: Pass
 Un (U1) 0.23005kV Total Judgement: Pass
 Freq(U1) 49.984 Hz (Element1)

Flicker measurement status: Complete
 Element judgement
 Displays the judgement of the average of dmax for the element whose measured data is displayed.
 Total judgement
 If the judgement of all elements being measurement is pass, Pass is indicated. Otherwise, Fail is indicated.
 Measured element

No.	dmax[%]	No.	dmax[%]
1	0.48	13	0.41
2	0.75 max	14	0.35
3	0.37	15	0.31
4	0.34	16	0.49
5	0.50	17	0.34
6	0.46	18	0.29 min
7	0.36	19	0.31
8	0.59	20	0.38
9	0.40	21	0.59
10	0.63	22	0.39
11	0.30	23	0.35
12	0.46	24	0.59
Limit		4.00	
Result (Average dmax)		0.43 Pass	

Judgement of the average of dmax

Displays the average of 22 dmax values excluding the maximum and minimum values. The value is compared to the limit, and the judgement (pass or fail) is displayed.

12.6 Executing the Measurement of dmax Caused by Manual Switching

- **Initializing the Measurement of dmax Caused by Manual Switching**
 - The initialization takes approximately 30 s.
 - Rms voltage Un and voltage frequency Freq are updated every 2 s while the initialization is in progress in the same manner as when the voltage fluctuation and flicker measurement is reset.
 - Keep the voltage of the power supply to be measured in steady-state condition while the initialization is in progress.
- **Rated Voltage Un and Voltage Frequency Freq**
 - If the assignment method of rated voltage is auto, the rms voltage at the start of the first measurement is used as rated voltage Un. The measured data is calculated with respect to rated voltage Un.
 - If the assignment method of rated voltage is Set, the rated voltage setting is displayed as Un(Set).
 - Rated voltage Un and voltage frequency Freq are fixed to the first measured values after the measurement of dmax caused by manual switching is started and are not updated.
- **Switching the Element for Displaying the Measurement Data**

You can select the element from below. The selectable items vary depending on the installed elements.
Element1, Element2, Element3, and Element4

Note

If an element that is not being measured is assigned to a display target element, <OFF> is displayed by the element number, and all measured data and judgement are displayed as blank.

- **Resetting the Measurement of dmax Caused by Manual Switching**

To initialize and restart the measurement, execute reset after the measurement of dmax caused by manual switching is complete and the flicker measurement status is indicating Complete. You cannot initialize or start the measurement in the Complete status.

Reset the measurement of dmax caused by manual switching to change the following settings.

 - Measurement conditions (chapter 4 in the *User's Manual IM760301-01E*)
 - Measurement conditions of the measurement of dmax caused by manual switching (section 12.3)

• **Flow Chart of the Measurement of dmax Caused by Manual Switching**
 (Transition Diagram of the Flicker Measurement Status)

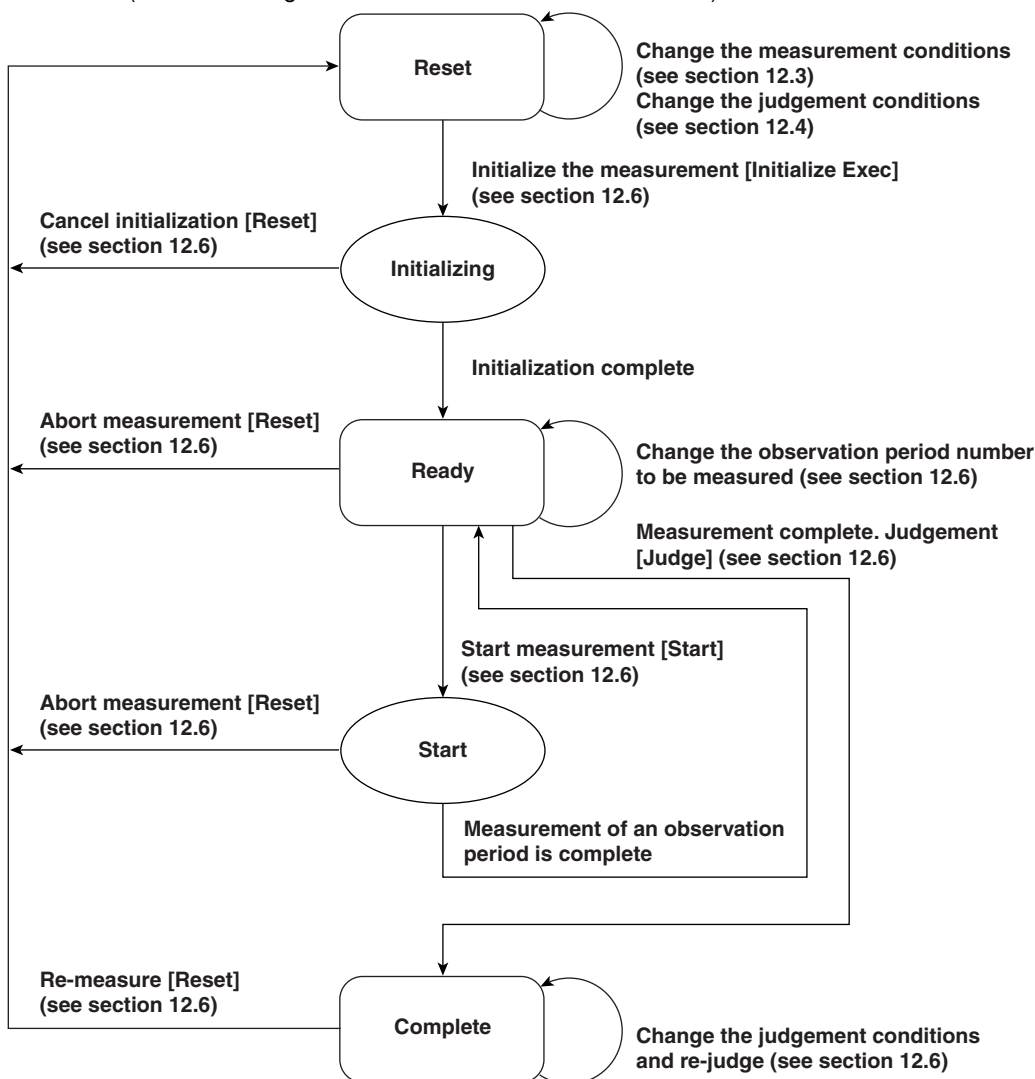

Reference sections are indicated in parentheses.
 Soft keys that you operate are indicated in brackets.

12.7 Voltage Fluctuation and Flicker Measurement Specifications

Normal Flicker Measurement Mode

Item	Specifications	
Measurement Items (Measurement Functions)	dc	Relative steady-state voltage change
	dmax	Maximum relative voltage change
	d(t)	The time during which the relative voltage change during a voltage fluctuation period exceeds the threshold level
	The maximum value within a observation period is displayed for the items above.	
	Pst	Short-term flicker value
	Plt	Long-term flicker value
One observation period	30 min to 15 s	
Observation period count	1 to 99	

Measurement of dmax Caused by Manual Switching Mode

Item	Specifications
Measurement Items (Measurement Functions)	dmax Maximum relative voltage change
One observation period	1 minute
Observation period count	24
Averaging	Average of 22 measured dmax values excluding the maximum and minimum values among 24 values

Items Common to Measurement Modes

Item	Specifications
Target voltage/frequency	230 V/ 50 Hz or 120 V/60 Hz
Measured item	All installed elements
Measured source input	Voltage (current measurement function not available)
Flicker scale	0.01 to 6400P.U. (20%) divided logarithmically into 1024 levels.
Display update	2 s (dc, dmax, and d(t)) For every completion of a observation period (Pst)
Communication output	dc, dmax, d(t), Pst, Plt, instantaneous flicker sensation (IFS), and cumulative probability function (CPF)
Printer output	Screen image
External storage output	Screen image
Accuracy	dc, dmax: 4% (at dmax = 4%) Pst: ±5% (at Pst = 1) Conditions for the accuracy above <ul style="list-style-type: none"> • Ambient temperature: 23 ± 1°C • Line filter: OFF • Input voltage range <ul style="list-style-type: none"> 220V to 250V at the 300V measuring range (50Hz) 110V to 130V at the 150V measuring range (60Hz)

Functional Limitations

Item	Specifications
Integration	Not allowed
Store	Not allowed
Synchronized measurement	Not allowed
Auto print	Not allowed
E-mail transmission	Not allowed

For a list of functional limitations, see appendix 10 in the *User's Manual IM760301-01E*.

13.1 Cycle-by-Cycle Measurement Function

Cycle-by-cycle measurement is a method by which the voltage, current, power, and other parameters are calculated for each cycle of the AC input signal with respect to the zero-crossing of the synchronization source signal. When the measurement of the specified frequency is complete, the measured values are listed in order by period.

The figure below shows the measurement periods when the measurement conditions of the cycle-by-cycle measurement are set as follows:

- Synchronization source: U1
- Synchronization source slope: Rising
- Measurement cycle count: 3 (The minimum value you can actually specify is 10.)

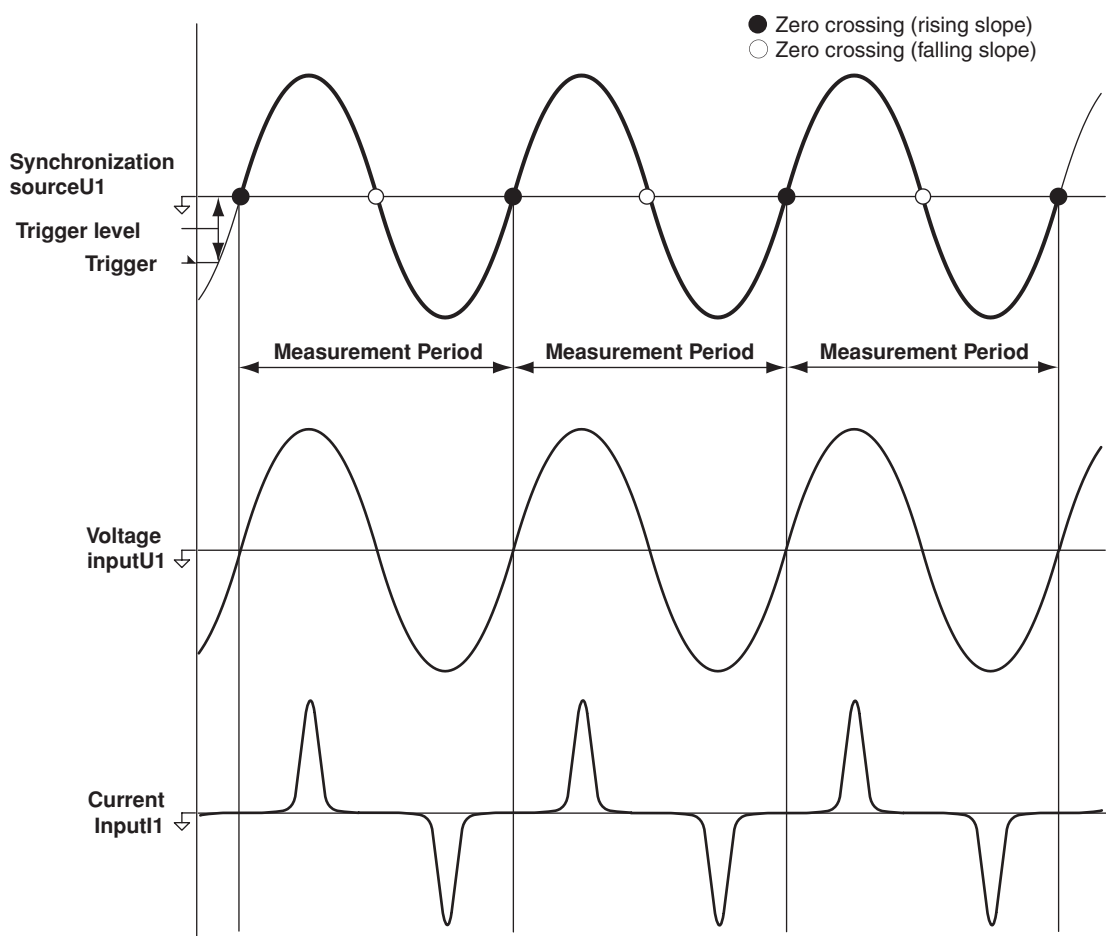

• **Types of Measurement Functions**

The following measurement functions are measured for each measurement element and wiring unit.

- | | |
|--|-------------------|
| Freq: Synchronization source frequency | I: Current*1 |
| U: Voltage*1 | S: Apparent power |
| P: Active power | λ: Power factor |
| Q: Reactive power | Torque |
| Speed | |
| Pm: Mechanical power | |

*1 RMS, MEAN, DC, or RMEAN value depending on the voltage or current mode setting.

13.1 Cycle-by-Cycle Measurement Function

- **Limitations on the Function and Measurement Function**

In cycle-by-cycle measurement mode, internal computation is processed differently from other measurement modes. Therefore, some functions such as waveform and bar graph displays on the screen and storage function cannot be used in this measurement mode. In addition, some measurement functions such as integration and efficiency computation cannot be carried out. For a list of functions with limitations and measurement functions that cannot be measured, see appendices 10 and 11 in the *User's Manual IM760301-01E*.

Note

In cycle-by-cycle measurement, the equation for apparent power and reactive power is fixed to TYPE 2. If TYPE 1 or TYPE 3 is selected and you select cycle-by-cycle measurement mode, the equation switches to TYPE 2. For details on the type of equations, see section 2.5 and 5.9 in the *User's Manual IM760301-01E*.

- **Data Update Interval**

The data update rate setting is invalid in cycle-by-cycle measurement mode. The display data is updated when the measurement of the specified number of cycles is completed. The display data is not updated until then. For example, if you are measuring a 50-Hz (20-ms) input signal for 1000 cycles, it takes at least 20 s from the start of the measurement until the measurement is completed and the measured values are displayed.

- **Saving the Cycle-by-Cycle Measurement Data**

To save the cycle-by-cycle measurement data on the WT3000, select Numeric for the item to be saved. For details, see section 9.3 in the *User's Manual IM760301-01E*.

• **Limitations on the Setting Changes and Execution of Operations in Cycle-by-Cycle Measurement Mode**

There are some functions whose settings cannot be changed in cycle-by-cycle measurement mode as shown below.

Setup Item	Cycle-by-Cycle Measurement Status		
	Reset	Start	Complete
Cycle-by-cycle measurement			
Synchronization source and trigger	Yes	View	View
Cycle count and timeout	Yes	View	View
Measurement start	Yes	No	No
Reset	–	Yes	Yes
Displayed items	Yes	Yes	Yes
Displayed cycle number	Yes	Yes	Yes
Measurement mode	Yes	No	No
Wiring and compensation			
Wiring system	Yes	View	View
Independent setting of elements	Yes	View	View
Efficiency and compensation	View	View	View
Voltage/current range	Yes	No	No
Auto range	No	No	No
Sensor transformation ratio	Yes	View	View
Crest factor	Yes	View	View
Voltage/current mode	Yes	No	No
Scaling	Yes	View	View
Filter	Yes	View	View
Averaging	No	No	No
Synchronization source	No	No	No
Measurement and computation ([MEASURE])	No	No	No
Frequency measurement	No	No	No
Cursor	–	–	–
NULL	No	No	No
Motor evaluation	Yes	View	View
Harmonic measurement	No	No	No
Displayed items [U/I/P][S/Q/λ/φ] [FU/FI/η]	Yes	Yes	Yes
[WP/q/TIME] [USER]	–	–	–
[ELEMENT]	Yes	Yes	Yes
Data update rate	No	No	No
Hold	Yes	Yes	Yes
Single measurement (display update)	Yes	Yes	Yes
Zero-level compensation	Yes	No	No
Integration	No	No	No
File operation	Yes	Yes	Yes
Set or execute the screen image storage	Yes	Yes	Yes
Set or execute the storage operation	No	No	No
Set or execute the print operation	Yes	Yes	Yes
Miscellaneous ([MISC])	Yes	Yes	Yes
Help	Yes	Yes	Yes

- Yes: The settings can be changed and the function can be executed.
- No: The settings can be changed and the function cannot be executed.
- View: The settings can be viewed but cannot be changed, and the function cannot be executed.
- : Does not function.

13.2 Setting the Cycle-by-Cycle Measurement Mode

Procedure

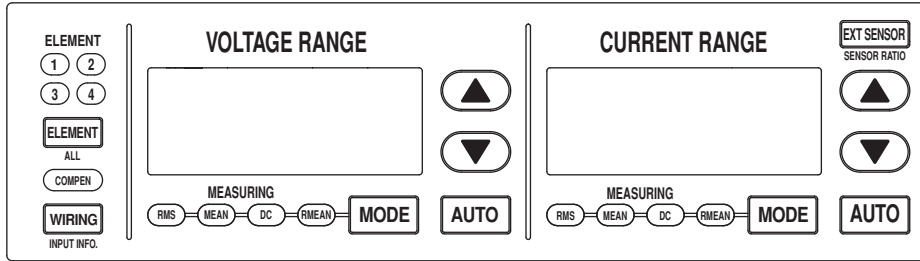

To exit the menu during operation, press **ESC** located above the soft keys.

In the procedural explanation below, the phrase “press the **cursor keys**” may be used. This phrase refers to the procedures for selecting items and entering values and character strings. For details on the procedures, see section 3.14 in the *User's Manual IM760301-01E*.

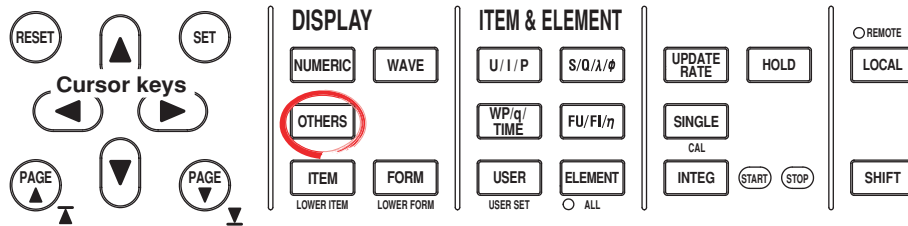

1. Press **OTHERS** to display the Others menu.
2. Press the **Next 1/3** soft key to display the Next 2/3 menu.
3. Press the **Cycle by Cycle** soft key.

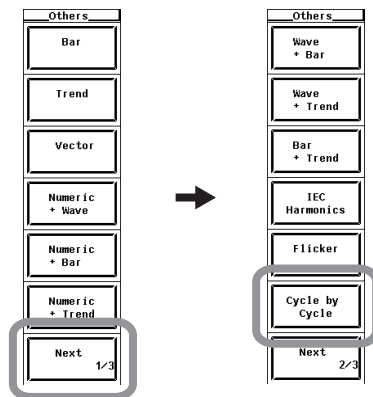

Explanation

• **Display Related to the Cycle-by-Cycle Measurement**

The figure below is a display example of cycle-by-cycle measurement.

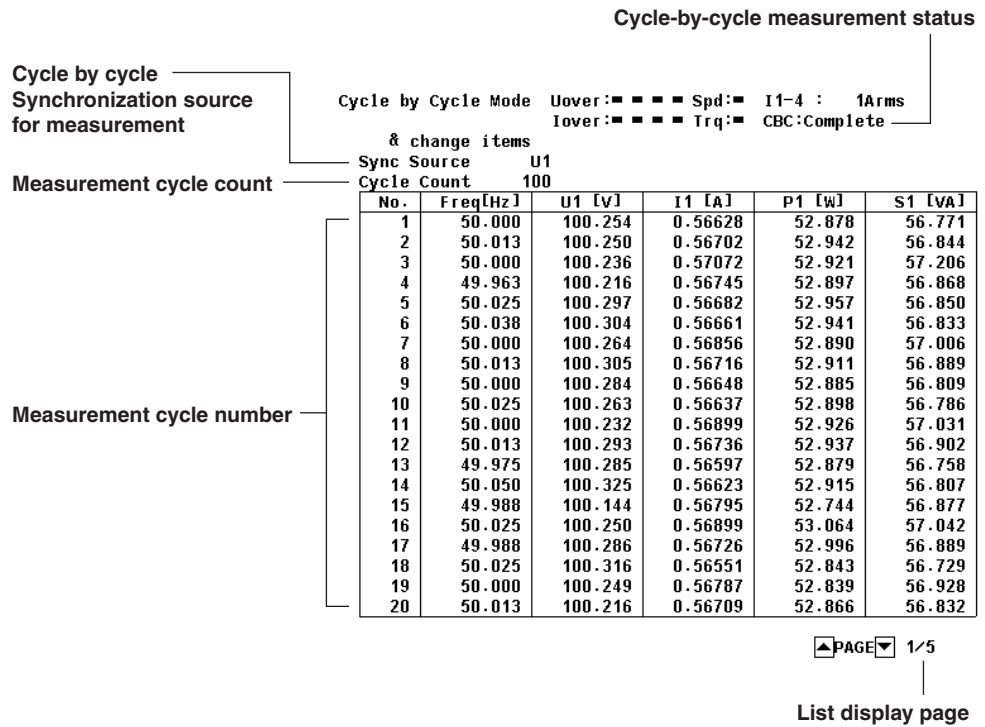

• **Cycle-by-Cycle Measurement Status**

The following five cycle-by-cycle measurement statuses are available.

Display	Meaning
Reset	Reset
Start	Measurement in progress
Complete	Complete
Time Out	Timeout
Freq Err	Frequency error

• **Limitations on Changing the Measurement Mode**

The WT3000 cannot switch to cycle-by-cycle measurement mode in the following conditions.

- When the master/slave synchronization measurement is set to slave.
- When the integration function is started or stopped.
- When auto print is ON.
- While storage or recall operation is in progress.
- While the storage medium is being accessed.
- While saving waveform sampling data to the storage medium.

13.3 Setting the Measurement Conditions

Procedure

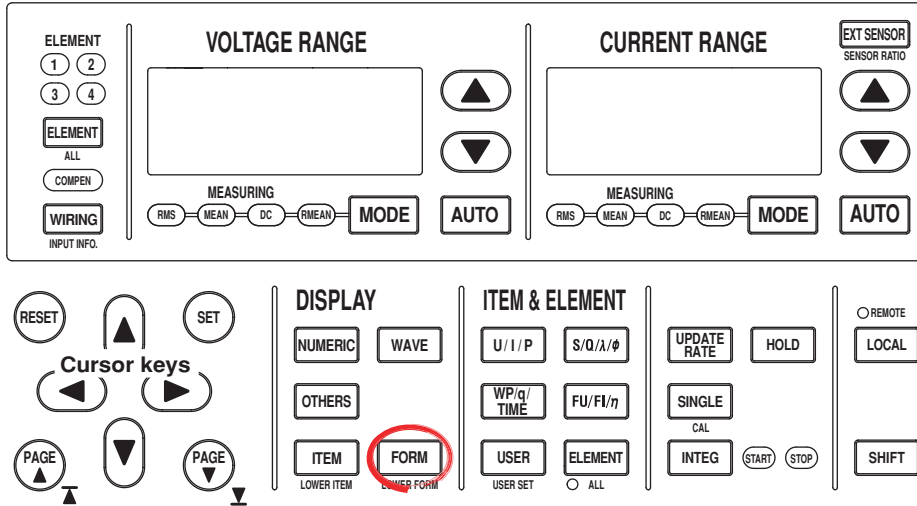

To exit the menu during operation, press **ESC** located above the soft keys.

In the procedural explanation below, the phrase “press the **cursor keys**” may be used. This phrase refers to the procedures for selecting items and entering values and character strings. For details on the procedures, see section 3.14 in the *User's Manual IM760301-01E*.

Check that the cycle-by-cycle measurement status is indicating Reset. If not, set the cycle-by-cycle measurement status to Reset according to the procedure in “Resetting the Cycle-by-Cycle Measurement” on page 13-14.

1. Press **FORM** to display the CBC Form menu.
- **Setting the Synchronization Source**
 2. Press the **Sync Source** soft key to display the synchronization source selection box.
 3. Press the **cursor keys** to select any of the elements/wiring units starting with U1.
 4. Press **SET** to confirm the new synchronization source.

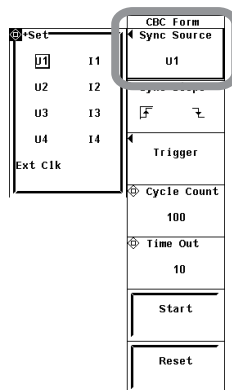

- Setting the Synchronization Source Slope**
 - Press the **Sync Slope** soft key to select f or \bar{f} .

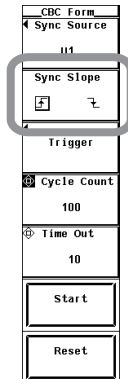

- Setting the Trigger**
 - Display the **Trigger** soft key to display the Trigger menu.

- Selecting the Trigger Mode**

- Press the **Mode** soft key to select Auto or Normal.

- Selecting the Trigger Source**

- Press the **Source** soft key to display the trigger source selection box.
- Press the **cursor keys** to select any of the elements/wiring units starting with U1.
- Press the **SET** key to confirm.

- Selecting the Trigger Slope**

- Press the **Slope** soft key to select f , \bar{f} , or $f\bar{f}$.

- Setting the Trigger Level**

- Press the **cursor keys** to set the trigger level.

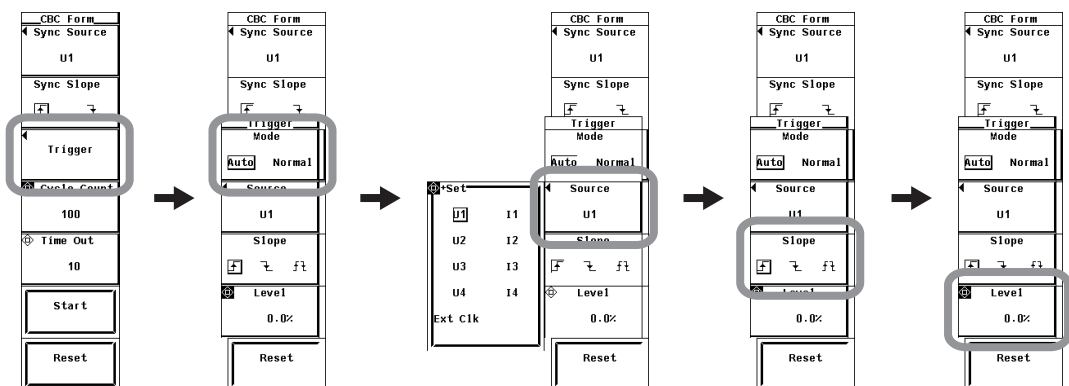

13.3 Setting the Measurement Conditions

- **Setting the Measurement Cycle Count**

13. Press the **Cycle Count** key.
14. Press the **cursor keys** to set the cycle count.

The screenshot shows a vertical menu titled "CBC Form". The menu items are: "Sync Source" (with a left arrow), "U1", "Sync Slope" (with a square icon containing a plus sign and a right arrow), "Trigger" (with a left arrow), "Cycle Count" (with a square icon containing a plus sign and a right arrow, highlighted with a red box), "Time Out" (with a square icon containing a plus sign and a right arrow), "10", "Start", and "Reset".

- **Setting the Measurement Timeout Value**

15. Press the **Time Out** soft key.
16. Press the **cursor keys** to set the timeout value.

The screenshot shows a vertical menu titled "CBC Form". The menu items are: "Sync Source" (with a left arrow), "U1", "Sync Slope" (with a square icon containing a plus sign and a right arrow), "Trigger" (with a left arrow), "Cycle Count" (with a square icon containing a plus sign and a right arrow), "Time Out" (with a square icon containing a plus sign and a right arrow, highlighted with a red box), "10", "Start", and "Reset".

- **Setting the Line Filter for the Cycle-by-Cycle Measurement**

- Set the line filter of the input element according to the procedure given in section 4.8 of the *User's Manual IM760301-01E*.
- Set the line filter of the motor input according to the procedure given in section 1.5.

Note

The line filter setting in cycle-by-cycle measurement mode is independent of the setting in other measurement modes. The initial setting is 50 kHz.

Explanation

- **Synchronization Source**

The synchronization source defines the cycle (period) over which the cycle-by-cycle measurement data is calculated. The WT3000 measures the voltage, current, power, and other parameters of the input signal for each cycle of the input signal selected for the synchronization source. For example, WT3000 measures the rms values for up to 3000 consecutive cycles from the first zero-crossing of the synchronization source signal after the measurement is started.

- Display Position of the Synchronization Position

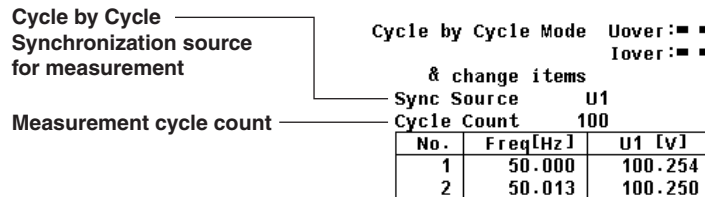

- **Selecting the Synchronization Source**

Select the synchronization source from below. The selectable items vary depending on the installed elements.

U1, I1, U2, I2, U3, I3, U4, I4, and Ext Clk*¹

*1 If you select "Ext Clk," cycle-by-cycle measurement is performed using the frequency of the signal applied to the external clock input connector as the synchronization source.

- **When Setting the Synchronization Source to Ext Clk**

Apply a clock signal to the external clock input connector (EXT CLK) on the rear panel according to the following specifications.



- **Ext Clk Specifications**

Item	Specifications
Connector type	BNC connector
Input level	TTL
Input waveform	50% duty ratio rectangular wave

CAUTION

Applying a voltage outside the range of 0 to 5 V to the external clock input connector (EXT CLK) can damage the instrument.

Note

- Set the synchronization signal to a signal with the same period as the source signal of cycle-by-cycle measurement. Selecting an input signal with little distortion for the PLL source allows stable cycle-by-cycle measurement. If the synchronization source waveform is distorted and the fundamental frequency cannot be measured, correct measurement results will not be obtained.
 - If the amplitude level of the signal applied to the element specified as the synchronization source is small with respect to the range, the fundamental frequency cannot be measured. Consequently, correct measurement results will not be obtained.
 - The synchronization source set according to the procedure in this section is specific to cycle-by-cycle measurement mode. It is functionally different from the synchronization source in other measurement modes such as normal measurement mode (see section 4.7 in the *User's Manual IM760301-01E*). The two settings are independent.
-

- **Synchronization Source Slope**

Set the synchronization source slope of cycle-by-cycle measurement. You can select the slope from below.

- \nearrow : Detects the zero-crossing (boundary of the measurement period) of cycle-by-cycle measurement when the synchronization source signal changes from negative to positive (rising edge).
- \searrow : Detects the zero-crossing (boundary of the measurement period) of cycle-by-cycle measurement when the synchronization source signal changes from positive to negative (falling edge).

- **Selecting the Trigger Mode**

Trigger mode defines the condition for starting the cycle-by-cycle measurement. You can select the mode from below.

- Auto
Enables auto mode.
 - If a trigger occurs within the trigger timeout value (approx. 100 ms), the cycle-by-cycle measurement is started on that trigger.
 - If a trigger does not occur within the trigger timeout value, the cycle-by-cycle measurement is automatically started when the timeout value elapses.

Note

If the period of the trigger is greater than or equal to 100 ms, use normal mode. If you select auto mode when the period of the trigger signal is greater than or equal to 100 ms, a timeout may occur before the trigger is activated. Consequently, the cycle-by-cycle measurement may not start on the specified trigger conditions.

- Normal
Enables normal mode.
 - Starts the cycle-by-cycle measurement when a trigger occurs.
 - The cycle-by-cycle measurement does not start if a trigger does not occur.

- **Selecting the Trigger Source**

Select the target to which the trigger condition is applied (trigger source) from below. The selectable items vary depending on the installed elements.

U1, I1, U2, I2, U3, I3, U4, I4, and Ext Clk (external clock)*

- * If the trigger source is set to Ext Clk, apply a signal according to the following specifications. If the trigger source is set to Ext Clk, the trigger level settings are void.

• **When Setting the Trigger Source to Ext Clk**

Apply a trigger signal to the external clock input connector (EXT CLK) on the rear panel according to the following specifications.



Item	Specifications
Connector type	BNC connector
Input level	TTL
Minimum pulse width	1 μ s
Trigger delay time	Within (1 μ s + 1 sample period)

CAUTION

Applying a voltage outside the range of 0 to 5 V to the external clock input connector (EXT CLK) can damage the instrument.

• **Input Circuit and Time Chart of the External Trigger Signal**

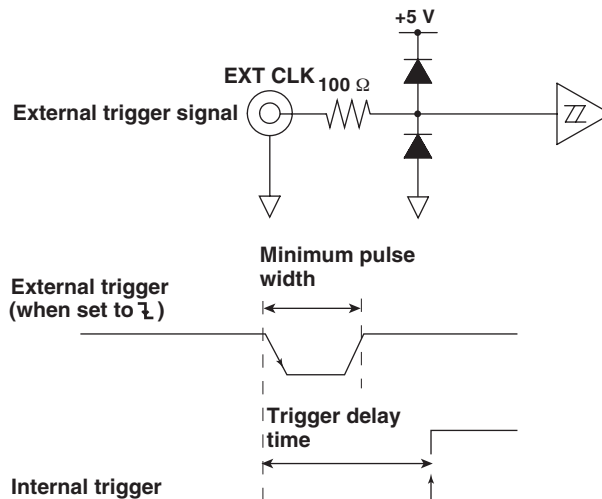

• **Selecting the Trigger Slope**

The up and down movement of a signal level is called a slope. When the slope is used as one of the trigger conditions, it is called a trigger slope. You can select the trigger slope from the following:

- \uparrow : The trigger occurs when the trigger source signal rises above the trigger level from a lower level.
- \downarrow : The trigger occurs when the trigger source signal falls below the trigger level from a higher level.
- $\uparrow\downarrow$: Trigger occurs on both the rising and falling cases.

13.3 Setting the Measurement Conditions

- **Setting the Trigger Level**

Trigger level refers to a level at which the trigger slope passes. When the slope of the trigger source passes through the specified trigger level on a rising or falling edge, a trigger occurs.

- The level can be set in the range of 0.0 to $\pm 100.0\%$.
 - The following value is taken to be 100%. With the vertical center of the screen taken to be the input zero line, the upper and lower limits of the waveform display screen are 100% and -100% , respectively.
 - If the crest factor is set to 3, the value that is three times the measurement range (if scaled, the range after scaling) of the voltage/current that is set for each element.
 - Likewise, if the crest factor is set to 6, the value that is six times the measurement range.
 - The trigger level setting is void when the trigger source is set to Ext Clk.
- **Measurement range: 100 Vrms when the crest factor is 3,
50 Vrms when the crest factor is 6**
 - **Trigger level: 25%**

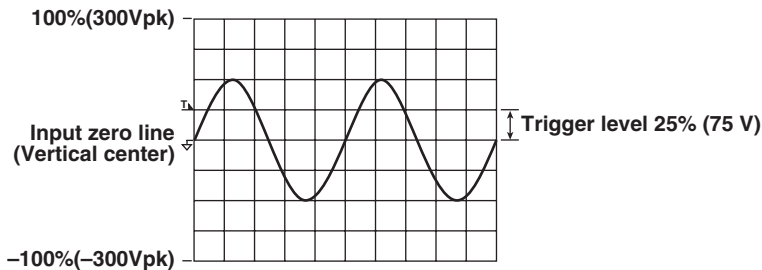

Note

- To prevent erroneous operation caused by noise, the trigger function uses approximately 2% hysteresis if the crest factor is set to 3. For example, if the trigger slope is set to \uparrow , a trigger occurs if the input signal passes through the trigger level on the rising edge after the input signal level falls approximately 2% below the trigger level. The trigger function uses approximately 4% hysteresis if the crest factor is set to 6.
 - The trigger settings are common with the waveform display of normal measurement mode.
-

- **Measurement Cycle Count**

Set the cycle count for which the cycle-by-cycle measurement is performed in the following range.

10 to 3000 times

- **Measurement Timeout Value**

If a given time (timeout value) elapses after the start of the measurement, the measurement is aborted in the middle. You can set the timeout value in the following range.

1 to 3600 s

Note

- The time it takes for the cycle-by-cycle measurement to complete is as follows:
Measurement time = Period of the synchronization source signal \times measurement cycle count + computation time
Set the timeout value to a value greater than the time above. A timeout occurs if it takes too long to measure the specified measurement cycle count such as when the status of the synchronization source signal changes or if an abnormal condition such as the measurement does not finish. This allows you to find out that the measurement signal has become abnormal. If the timeout value is shorter than the measurement time above, a timeout always occurs when the measurement is started, and the measurement cannot be completed.
 - If a measurement times out, the measured data is not displayed.
-

13.4 Executing the Cycle-by-Cycle Measurement

Procedure

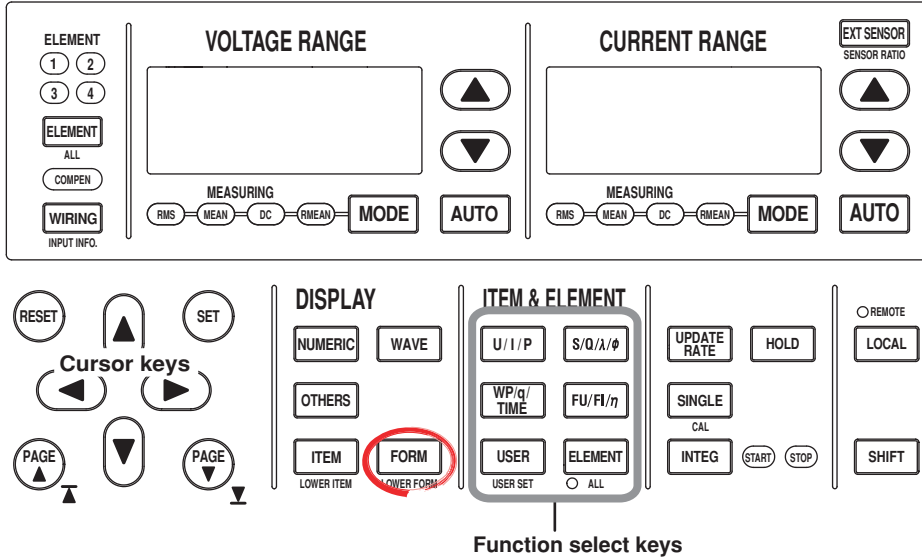

To exit the menu during operation, press **ESC** located above the soft keys.

In the procedural explanation below, the phrase “press the **cursor keys**” may be used. This phrase refers to the procedures for selecting items and entering values and character strings. For details on the procedures, see section 3.14 in the *User’s Manual IM760301-01E*.

Check that the cycle-by-cycle measurement status is indicating Reset. If not, set the cycle-by-cycle measurement status to Reset according to the procedure in “Resetting the Cycle-by-Cycle Measurement” on page 13-14.

1. Set the measurement range, scaling, etc. (see chapter 4 in the *User’s Manual IM760301-01E*).
- **Starting the Cycle-by-Cycle Measurement**
 2. Press **FORM** to display the CBC Form menu.
 3. Press the **Start** soft key to start the cycle-by-cycle measurement. The cycle-by-cycle measurement status indicates Start.

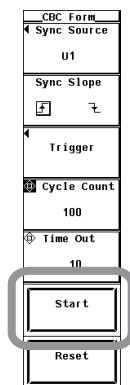

13.4 Executing the Cycle-by-Cycle Measurement

- **Aborting the Cycle-by-Cycle Measurement**

4. Press the **Reset** soft key. An Alert dialog box appears.
5. Press the **cursor keys** to select OK.
6. Press **SET**. The cycle-by-cycle measurement is aborted. All the measured data up to that point are discarded. The cycle-by-cycle measurement status indicates Reset. To continue the cycle-by-cycle measurement, select Cancel in step 5 and press **SET**.

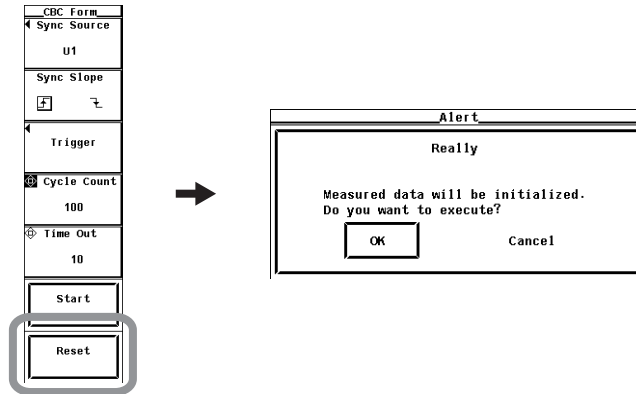

- **Aborting the Cycle-by-Cycle Measurement Automatically**

7. If the measurement is not completed within the timeout value, a timeout occurs, and the measurement is aborted. The cycle-by-cycle measurement status indicates Time Out. The Measure data is not displayed.

- **Completing the Cycle-by-Cycle Measurement**

8. The cycle-by-cycle measurement stops automatically, when the measurement of the specified measurement cycle is completed. The cycle-by-cycle measurement status indicates Complete, and the measured data is displayed. If the frequency of the synchronization source exceeds the frequency range (see section 13.5), the cycle-by-cycle measurement status indicates Freq Err. The measured data of frequencies outside the range is indicated as Error.

There are four ways to change the displayed items of measured data list number 1 to 5. For the procedures of each method, see the pages indicated below.

- Changing the displayed items using the function select key (see below)
- Selecting the displayed items from the menu (see page 13-15)

- **Changing the Displayed Items Using the Function Select Key**

The display of the measurement functions of U, I, P, S, Q, λ , Freq and the element/wiring unit can be changed using function select keys.

- **Selecting the Item to Be Changed**

9. Press **ESC** to clear the soft key menu at the right of the screen.
10. Press the **cursor keys** to select the item to be changed. The item to be changed is highlighted.

• **Changing the Measurement Function**

11. Press the **U/I/P**, **S/Q/λ/φ**, or **FU/FI/η** function select key to select the displayed measurement function.

Press the key corresponding to the measurement function you wish to display.

 - The display switches each time the U/I/P key is pressed as follows: U, I, P, and original display.
 - The display switches each time the S/Q/λ/φ key is pressed as follows: s, Q, λ, and original display.
 - The display switches each time the FU/FI/η key is pressed as follows: Freq and original display.

• **Changing the Element/Wiring Unit**

12. Press **ELEMENT** to select the element/wiring unit.

• **Changing the Element/Wiring Unit Collectively**

13. Press **SHIFT+ELEMENT (ALL)**. ALL LEDs illuminate, and the element/wiring unit of all the displayed items of measured data list number 1 to 5 can be changed collectively.

• **Selecting the Displayed Items from the Menu**

9. Press **ITEM** to display the CBC Items menu.

• **Selecting the Data List to Be Changed**

10. Press the **List Item No.** soft key.
11. Press the **cursor keys** to select the list number to be changed.

• **Changing the Measurement Function**

12. Press the **Function** soft key to display the measurement function selection box.
13. Press the **cursor keys** to select any of the measurement functions starting with Freq.
14. Press **SET**. The symbol for the selected measurement function and the numeric data are displayed in the data list to be changed.

• **Changing the Element/Wiring Unit**

15. Press the **Element/Σ** soft key to display the element/wiring unit selection box.
16. Press the **cursor keys** to select any of the elements/wiring units starting with Element1.
17. Press **SET**. The symbol for the selected element number or wiring unit and the numerical data are displayed in the data list to be changed.

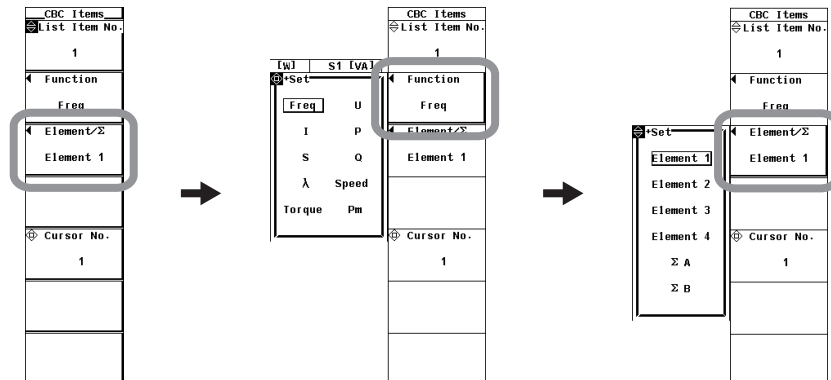

• **Page Scrolling the Screen (PAGE ▼▲ key)**

18. Press **PAGE ▼** or **PAGE ▲** to scroll the page.
 - Press PAGE ▼ to display the next page.
 - Press PAGE ▲ to display the previous page.

13.4 Executing the Cycle-by-Cycle Measurement

- **Page Scrolling the Screen (Cursor Keys)**

19. Press **ESC** to clear the soft key menu at the right of the screen.
20. Press the **cursor keys (up and down keys)** to move the highlight.
 - If you press the down cursor key when the highlight is at the bottom row, the next page is displayed.
 - If you press the up cursor key when the highlight is at the top row, the previous page is displayed.

- **Jumping Pages**

21. Press **ITEM** to display the CBC Items menu.
22. Press the **Cursor No.** soft key.
23. Press the **cursor keys** to set the cycle number. The page containing the cycle number is displayed.

CBC Items	
List Item No.	1
Function	Freq
Element 1/2	Element 1
Cursor No.	1

- **Jumping to the Last or First Page**

24. Press **SHIFT+PAGE ▼ (▼)** or **SHIFT+PAGE ▲ (▲)**.
 - Press **SHIFT+PAGE ▼ (▼)** to display the last page.
 - Press **SHIFT+PAGE ▲ (▲)** to display the first page.

- **Resetting the Cycle-by-Cycle Measurement**

25. Press **FORM** to display the CBC Form menu.
26. Press the **Reset** soft key. An Alert dialog box appears.
27. Press the **cursor keys** to select OK.
28. Press **SET**. The cycle-by-cycle measurement is reset. The measured data and judgement results up to that point are discarded. The cycle-by-cycle measurement status indicates Reset. To not reset, select Cancel in step 27 and press **SET**.

CBC Form	
Sync Source	U1
Sync Slope	↕
Trigger	
Cycle Count	100
Time Out	10
Start	
Reset	

➔

Alert	
Really	
Measured data will be initialized. Do you want to execute?	
OK	Cancel

Explanation

• **Display When the Cycle-by-Cycle Measurement Is Complete**

A display example is shown below.

Hardware detection of peak over-range

Indicated if any hardware peak over-range is detected during the measurement of all cycles

Cycle by Cycle Synchronization source for measurement

Measurement cycle count

Measurement cycle number

Cycle-by-cycle measurement status
 Cycle by Cycle Mode Uover: ■ ■ ■ ■ Spd: ■ I1-4 :500mA rms
 Iover: ■ ■ ■ ■ Trq: ■ CBC:Complete

Sync Source		U1					
Cycle Count		100					
No.	Freq[Hz]	U1 [V]	I1 [A]	P1 [W]	S1 [VA]		
1	50.000	100.380	↑+ 572.547m	53.1891	57.4721		
2	49.975	100.354	569.683m	53.2064	57.1700		
3	50.000	100.434	570.109m	53.3339	57.2586		
4	50.000	100.423	568.562m	53.1483	57.0965		
5	49.988	100.390	568.144m	53.0864	57.0358		
6	49.975	100.387	↓- 571.923m	53.1613	57.4137		
7	50.000	100.415	568.813m	53.1918	57.1171		
8	49.988	100.407	569.107m	53.2024	57.1422		
9	50.000	100.410	568.581m	53.1674	57.0912		
10	49.963	100.328	↓- 571.212m	53.0456	57.3085		
11	50.013	100.383	569.012m	53.2195	57.1190		
12	49.988	100.404	569.590m	53.2449	57.1893		
13	49.988	100.419	568.745m	53.1938	57.1129		
14	49.988	100.425	↓- 571.397m	53.1492	57.3827		
15	50.000	100.463	568.506m	53.1801	57.1140		
16	49.988	100.426	568.047m	53.1140	57.0465		
17	49.988	100.421	568.742m	53.1842	57.1138		
18	49.963	100.373	↓- 572.551m	53.1713	57.4686		
19	50.013	100.463	569.249m	53.2619	57.1884		
20	49.988	100.434	568.199m	53.1188	57.0665		

▲PAGE▼ 1/5

List display page
Displays the current page number.

Detection of peak over-range data

For voltage (U), current (I), speed, and torque, ↑+ or ↓- is displayed in front of the data value if peak over-range occurs during the measurement of the cycle for which the data is displayed.

- ↑+ :Positive peak over-range
- ↓- :Negative peak over-range
- ↑± :Positive and negative peak over-range

Note

- If the synchronization source signal is distorted or high-frequency noise is superimposed on the signal, zero-crossing other than that of the fundamental frequency occurs. As a result, a range different from the cycle of the fundamental frequency may be measured. If this happens, turn ON the frequency filter.
- If the level of the synchronization source signal is less than the zero-crossing detection level, the zero-crossing cannot be detected correctly. As a result, the measured values may be unstable, or a timeout may occur.
- If the timeout value is shorter than the product of the period of the synchronization source signal and the measurement cycle count, timeout always occurs, and the measurement cannot be completed.

• **Peak Over-Range Detection**

There are two methods for detecting peak over-range.

- Detection by data
Detects peak over-range in the data from the A/D converter during the measurement of the cycle for which the data is displayed.
- Detection by hardware
Detects peak over-range that cannot be detected using the "detection by data" method such as pulse noise with a peak width that is shorter than the sampling interval of the A/D converter.

If a peak over-range is detected, the data of the cycle-by-cycle measurement may not be correct. Increase the measurement range so that peak over-range does not occur.

13.4 Executing the Cycle-by-Cycle Measurement

- **Display Updating during the Cycle-by-Cycle Measurement**

Even if you start the cycle-by-cycle measurement, [-----] (no data) is displayed until the measurement is completed. When the measurement is completed, the measured data is displayed.

- **Switching the Element for Displaying the Measurement Data**

- You can select the element/wiring unit from the choices below. The selectable items vary depending on the installed elements.
Element1, Element2, Element3, Element4, ΣA , and ΣB
- If there are no elements that are assigned to the selected wiring unit, there is no numeric data. Thus, [-----] (no data) is displayed in this case. For example, if elements are assigned to ΣA and no elements are assigned to ΣB , then the measurement function for ΣB shows [-----] (no data).

- **Page Scrolling the Screen**

A single page displays a list of measured data of 20 measurement cycles. If the measurement cycle count exceeds 20, the data is displayed on multiple pages. In this case, you can scroll or jump the page to switch the displayed page.

- **Resetting the Cycle-by-Cycle Measurement**

To restart the cycle-by-cycle measurement, execute reset and restart the measurement when the cycle-by-cycle measurement status is indicating Complete. You start the measurement in the Complete status.

Reset the cycle-by-cycle measurement to change the following settings.

- Measurement conditions (chapter 4 in the *User's Manual IM760301-01E*)
- Measurement conditions of the cycle-by-cycle measurement (section 13.3)

- **Flow Chart of the Cycle-by-Cycle Measurement**

(Transition Diagram of the Cycle-by-Cycle Measurement Status)

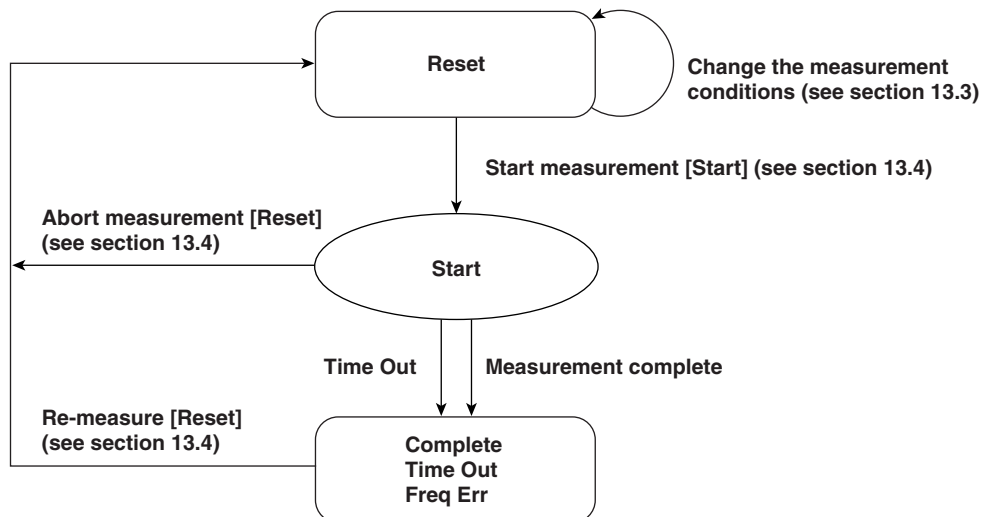

Reference sections are indicated in parentheses.
Soft keys that you operate are indicated in brackets.

Note

You can save the measured data of the cycle-by-cycle measurement to a file in CSV format. For the procedure to save the data, see section 9.3 in the *User's Manual IM760301-01E*. To save the data, select Numeric for the item to be saved.

13.5 Cycle-by-Cycle Measurement Specifications

Measurement Function

Item	Specifications
Measurement items (Measurement functions)	Freq Synchronization source frequency U Voltage I Rms current P Active power S Apparent power Q Reactive power λ Power factor Speed Torque Pm Mechanical power
Measurement cycle count	10 to 3000
Measurement timeout value	0, 1 to 3600 s (times out at approx. 24 hours if 0 is specified)
Frequency measuring range	1 Hz to 1 kHz (when the synchronization source for the cycle-by-cycle measurement is U or I) 0.1 Hz to 1 kHz (when the synchronization source for the cycle-by-cycle measurement is EXT CLK)
Accuracy	U, I (direct input), P, Speed, and Torque Add $(0.3 + 2 \times f)\%$ of reading + $(0.05 + 0.05 \times f)\%$ of range to the accuracy when the line filter is OFF in normal measurement (with the line filter turned ON) I (external sensor input) Add $(100 + 100 \times f) \mu\text{V}$ to the accuracy above Freq Add $(0.3 + 2 \times f)\%$ of reading to the accuracy in normal measurement The variable f is the frequency of the synchronization source for the cycle-by-cycle measurement in unit of kHz.

Functional Limitations

Item	Specifications
Integration	Not allowed
Store	Not allowed
Synchronized measurement	Not allowed
Auto print	Not allowed
E-mail transmission	Not allowed

For a list of functional limitations, see appendix 10 in the *User's Manual IM760301-01E*.

Index

Symbols

	Page
Δ Measure	6-2
1/Fundamental	7-27
1/Total	7-27
16 Items	7-12
180dpi	5-14
360dpi	5-14
4 Items	7-12
8 Items	7-12

A

	Page
Abort	5-14
ALL Items	7-12
anti-aliasing filter	7-28, 7-38
auto print	2-12

B

	Page
Bar	7-30
Bar C1 +	7-32
Bar C2 x	7-32
Bar Cursor	7-32
bar graph	7-8
bar graph display range	7-31
bar graph, number of split windows	7-31
Bar Item	7-30

C

	Page
color output	5-14
Comment	2-8, 5-14
Computed Points	11-10
computed points, number of	11-10
computed waveform, scale of	10-9, 10-10, 10-11, 10-12
Connect Log List	5-21
CPF	12-1
cumulative probability function	12-1
Current Grouping	9-9
CURSORS	7-32
cursor measurement	11-17
cycle-by-cycle measurement	13-1
cycle-by-cycle measurement status	13-5

D

	Page
d(t)	12-2, 12-12
D/A output	3-1
D/A output connector, pin arrangement of	3-1
D/A output items	3-3, 3-4
D/A Output Rated Time	3-5
D/A output voltage	3-8
D/A zoom	3-10
dc	12-2, 12-12
default gateway	5-3, 5-6
delta computation	6-1
delta computation, determination of	6-5
delta connection	6-1
DHCP	5-3, 5-5

differential current	6-1
differential voltage	6-1
distortion factor, equation of	7-27
dmax	12-2, 12-12
dmin	12-9, 12-10
DNS	5-3, 5-5, 5-6
DNS server address	5-7
domain name	5-4, 5-6, 5-7
domain suffix	5-7
dual list	7-7, 7-13

E

	Page
e-mail, sending of	5-16
End Order	7-31
ESC-P	5-13
Ext Clk	13-9
EXT HOLD	3-12
EXT PRINT	3-12
EXT RESET	3-12
EXT SINGLE	3-12
EXT START	3-12
EXT STOP	3-12
external trigger signal	13-11

F

	Page
feeding the paper	2-5
FFT	11-1
FFT data length	7-38
FFT mode	11-5, 11-6
FFT processing word length	7-38
FFT source	11-8
fixed range mode	3-10
FlatTop	11-11
flicker	12-2
flicker measurement status	12-6
Freq Err	13-5
FTP client function	5-9
FTP Passive	5-27
FTP passive mode	5-26
FTP server function	5-19

G

	Page
Grouping	9-8

H

	Page
Hanning	11-11
harmonic current factor	7-44
harmonic distortion factor	7-44
harmonic group	9-3
Harmonic Measurement Software	9-1
harmonic subgroup	9-3
harmonic voltage factor	7-44
hcf	7-44
hdf	7-44
hvf	7-44

Index

I	Page
IEC harmonic measurement	9-1
IEC Harmonic Measurement Mode	9-6
IFS	12-1
lhdf	7-27
impedance	7-43
instantaneous flicker sensation	12-1
INTEG BUSY	3-12
integrated D/A output, rated time of	3-8
Interharmonics	9-2
Interval	5-17
IP address	5-3, 5-6
lthd	7-27

J	Page
jumping	7-13

L	Page
line filter	1-10
list display	7-6
logging list	5-21
Login Name	5-10
long-term flicker value	12-3, 12-13
LPR Name	5-13
LPR Server	5-13
LPR Time Out	5-27

M	Page
MAC address	5-25
Mail Address	5-17
mail address of destination	5-17
Mail Server	5-17
Mail Setup	5-16
Mail Test	5-18
MailBaseTime	5-17
manual range mode	3-10
maximum harmonic order to be measured	7-25
maximum relative voltage change	12-2, 12-12
measured order	7-25
measurement of dmax caused by manual switching	12-1, 12-23
Min Order	7-25
minimum harmonic order to be measured	7-25
MISC	5-19
motor efficiency	1-24

N	Page
Net Print	5-13
Net Print Setup	5-12
Network	5-19
network connection	5-1
network printer	5-12
normal flicker measurement	12-1
normal measurement value	7-2

O	Page
one-to-one connection	5-1
order	7-18, 7-25
output command	5-13

P	Page
page scroll	7-12
Paper Feed	2-5
paper, feeding of	2-5
password	5-10, 5-20, 5-21
Phdf	7-27
pin arrangement	3-1, 4-1
PLL source	7-3, 7-22
Plt	12-3, 12-13
Pm, scaling of	1-19
Pole	1-21
poles, number of	1-21
power spectrum	11-1, 11-14
power spectrum, display type of	11-14
primary	5-4
PRINT	2-8
printer name	5-13, 5-15
printer roll paper	2-6
printer server	5-13, 5-15
Pst	12-3, 12-13
Pthd	7-27
pulse count	1-13
pulse input range	1-12
Pulse N	1-13
Pulse Range	1-12, 1-13
Pulse Rated Lower	1-14
Pulse Rated Upper	1-14
pulse rating	1-14

R	Page
Range Mode	3-10
Rated Max	3-10
Rated Min	3-10
rated voltage	12-8, 12-10
re-judgement	12-26
re-measurement	12-25
reactance	7-43
Rect	11-11
rectangular	11-11
relative steady-state voltage change	12-2, 12-12
remote control	3-12
resistance	7-43
Resolution	5-14
revolution signal input connector	1-2
revolution signal type	1-4
RGB video signal	4-1
roll paper	2-6

S	Page
Scaling of the Computed Waveform	10-10
secondary	5-4
Sense Type	1-4, 1-5
short-term flicker value	12-3, 12-13
signal assignment	3-1, 4-1
single list	7-6, 7-13
slip	1-21
SMTP Time Out	5-27
speed	1-2, 1-4
speed, scaling of	1-17
star connection	6-1
Start Order	7-31
steady-state condition	12-2
steady-state range	12-9, 12-10
subnet mask	5-3, 5-6
Sync Speed Source	1-22

synchronization source	1-10, 13-6
synchronous speed	1-21, 1-22

T	Page
TCP/IP	5-2
TCP/IP Setup	5-2
telephone harmonic factor	7-44
telephone influence factor	7-44
test transmission	5-18
thd	7-27, 7-44
Thd Formula	7-27
thf	7-44
tif	7-44
Time Out	5-20, 13-5
time window	11-11
timeout	13-5
timeout value	5-10, 5-20, 5-21
Timeout Warning Display of the PLL Lock	8-5
timeout warning of the PLL lock	8-5
TORQUE	1-3
Torque	1-5
torque, scaling of	1-18
torque signal input connector	1-3
torque signal type	1-5
total efficiency	1-24
total harmonic distortion	7-44
total value	7-2
transmission interval	5-17
transmission, time of	5-17
trigger level	13-12
trigger mode	13-10
trigger slope	13-11
trigger source	13-10

U	Page
Uhdf	7-27
upper limit of the measured order	7-26
User Account	5-19
user name	5-20, 5-21
Uthd	7-27

V	Page
Vector	7-35
vector display	7-8
vector, zooming in on	7-36
VGA	4-1
video signal output connector, pin arrangement of	4-1
voltage grouping	9-8

W	Page
waveform computation	10-1
waveform computation mode	10-4
Waveform Equation	10-5
wide bandwidth harmonic measurement	8-1
wide bandwidth harmonic measurement mode	8-3
window function	7-38

Z	Page
zero display	7-14
zero suppression	7-14
zero-crossing	13-1